

Buenos Aires, 01 de diciembre de 2025

GEN-1.100-3135

Sr. Director Manuel Morrone
Dirección Provincial de Evaluación de Impacto Ambiental
Ministerio de Ambiente de la provincia de Buenos Aires

**Ref.: Presentación Adenda al Estudio de Impacto Ambiental
Parque Eólico Villalonga I
“Planta almacenamiento de Energía y LMT de vinculación”
Expediente N° 2145-1076/15 Alc. 1**

De mi mayor consideración:

Por la presente me dirijo a Ud. a fin de presentar la **Adenda al Estudio de Impacto Ambiental Parque Eólico Villalonga I “Planta almacenamiento de Energía (PA Villalonga) y LMT de vinculación” a ubicarse dentro del predio del PE Villalonga I**, de la firma GENNEIA S.A. conforme a lo establecido por la normativa provincial vigente.

La presente Adenda realiza la incorporación de información al contenido del Expediente N° 2145-1076/15 Alc. 1 relacionado con la presentación del Estudio de Impacto Ambiental del Parque Eólico Villalonga I (EIA PEVIL), presentados por GENNEIA S.A. El documento tiene por objetivo informar a la autoridad ambiental, de dichas incorporaciones, en función de lo requerido por la normativa provincial.

El mencionado Proyecto “PA Villalonga” consiste en la construcción de una Planta de Almacenamiento de Energía con el objetivo de asegurar el suministro de energía eléctrica de largo plazo e incentivar el abastecimiento de energía renovable y uso eficiente de la misma, logrando de esta manera, mejorar las condiciones del SADI. La PA Villalonga contará con una potencia nominal declarada de 100 MW en el punto de interconexión, una capacidad instalada de 400 MWh lo cual proporcionan almacenamiento para entregar 4 horas de energía continuas a potencia continua.

A tal fin se adjuntan a la presente:

- Adenda al EIA rubricado por la profesional inscrita en el RUPAYAR.
- Anexos

A disposición por cualquier consulta, cordialmente.

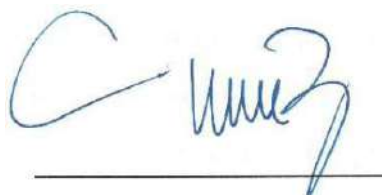

Fernando Resende
Gerente SHyMA



Lic. MARIA LAURA MUÑOZ
RUP - 000438
OPDS



► **Cliente.** GENNEIA S.A.

Ubicación. Partido de Patagones – Pcia. de Buenos Aires

Fecha. 04 de diciembre de 2025



Informe. EIA PEVI 001-25 Adenda

**Adenda - Estudio de Impacto Ambiental
Parque Eólico Villalonga I
Planta de Almacenamiento de Energía
y LMT de vinculación**

Expediente N° 2145-1076/15 Alc. 1

 **Scudelati & Asociados**
A s e s o r e s



EL NABA LAZARONI
S.A. 2018
C.A.B.

| | | |
|---|--|---|
|  | Adenda - Estudio de Impacto Ambiental Parque Eólico Villalonga I Planta almacenamiento de Energía y LMT de vinculación |  |
| Cliente. GENNEIA S.A. | | EIA PEVI 001-25 Adenda |
| Autor. Scudelati & Asociados S.A. | | www.scudelati.com |

ADENDA - ESTUDIO DE IMPACTO AMBIENTAL
PARQUE EÓLICO VILLALONGA I
PLANTA DE ALMACENAMIENTO DE ENERGÍA Y LMT DE VINCULACIÓN

ÍNDICE

| | |
|---|----------|
| 1. RESUMEN EJECUTIVO..... | 4 |
| 2. INFORMACIÓN GENERAL..... | 6 |
| 2.1. DATOS DEL PROPONENTE | 6 |
| 2.2. DATOS DEL RESPONSABLE PROFESIONAL..... | 6 |
| 3. MEMORIA DESCRIPTIVA | 8 |
| 3.1. DENOMINACIÓN Y DESCRIPCIÓN GENERAL DEL PROYECTO..... | 8 |
| 3.2. DESCRIPCIÓN DETALLADA DE LOS EQUIPOS..... | 11 |
| 3.3. ETAPAS DEL PROYECTO Y CRONOGRAMA | 19 |
| 3.4. ETAPA DE CONSTRUCCIÓN | 19 |
| 3.5. ETAPA DE OPERACIÓN Y MANTENIMIENTO..... | 23 |
| 3.6. ETAPA DE ABANDONO..... | 23 |
| 3.7. CONSUMO DE ENERGÍA. TIPO. CANTIDAD. CONSUMO POR UNIDAD DE TIEMPO..... | 24 |
| 3.8. CONSUMO DE COMBUSTIBLE. TIPO. CANTIDAD. | 25 |
| 3.9. CONSUMO DE AGUA..... | 25 |
| 3.10. DETALLE DE MATERIA PRIMA E INSUMOS..... | 26 |
| 3.11. CANTIDAD DE PERSONAL EMPLEADO | 26 |
| 3.12. VIDA ÚTIL | 27 |
| 4. IDENTIFICACIÓN Y VALORACIÓN DE IMPACTOS AMBIENTALES... 28 | |
| 4.1. POTENCIALES IMPACTOS AMBIENTALES EMERGENTES..... | 28 |
| 5. MEDIDAS DE CONTROL DE LOS IMPACTOS AMBIENTALES..... 29 | |
| 5.1. PLAN DE GESTIÓN AMBIENTAL..... | 29 |
| 5.2. PLAN DE VIGILANCIA Y CONTROL AMBIENTAL..... | 29 |
| 5.3. PLAN DE CONTINGENCIAS | 29 |



| | | |
|---|---|---|
|  | <p style="text-align: center;">Adenda - Estudio de Impacto Ambiental Parque Eólico Villalonga I Planta almacenamiento de Energía y LMT de vinculación</p> |  |
| Cliente. GENNEIA S.A. | EIA PEVI 001-25 Adenda | |
| Autor. Scudelati & Asociados S.A. | www.scudelati.com | |

6. BIBLIOGRAFÍA 30

ANEXO 01 – LAYOUT DEL PROYECTO

ANEXO 02 – ESPECIFICACIONES TÉCNICAS SISTEMA ACTIVO DE SUPRESIÓN DE FUEGO BAJO GAS

ANEXO 03 - ESPECIFICACIONES TÉCNICAS DE LOS EQUIPOS

| | | |
|---|--|---|
|  | Adenda - Estudio de Impacto Ambiental Parque Eólico Villalonga I Planta almacenamiento de Energía y LMT de vinculación |  |
| Ciente. GENNEIA S.A. | | EIA PEVI 001-25 Adenda |
| Autor. Scudelati & Asociados S.A. | | www.scudelati.com |

1. RESUMEN EJECUTIVO

La presente Adenda se realiza con el objetivo de incorporar información al contenido del **Expediente 2145-1076/15 alcance 1**, relacionado con la presentación del **Estudio de Impacto Ambiental del Parque Eólico Villalonga I (EIA PEVI)**, presentados por GENNEIA S.A. El documento tiene por objetivo informar a la autoridad ambiental provincial, de dichas incorporaciones, en función de lo requerido por la normativa provincial.

El PEVI, actualmente en operación, obtuvo la Declaración de Impacto Ambiental (DIA) el 18 de octubre de 2018 (Resolución N° 959/18).



El objetivo principal del documento es informar a la Autoridad Provincial el proyecto de construcción de una Planta de Almacenamiento de Energía denominada “PA Villalonga” y Línea de Media Tensión de vinculación (LMT), a ubicarse dentro del predio del PEVI, con el objetivo de asegurar el suministro de energía eléctrica de largo plazo e incentivar el abastecimiento de energía renovable y uso eficiente de la misma, logrando de esta manera, mejorar las condiciones del SADI.

La PA Villalonga contará con una potencia nominal declarada de **100 MW** en el punto de interconexión, una capacidad instalada de **400 MWh** lo cual proporcionan almacenamiento para entregar 4 horas de energía continuas a potencia continua.



La variación principal, respecto al proyecto original, es la instalación de la nueva PA Villalonga y el tendido de la LMT de vinculación. Conforme esto, el área afectada se incrementará en un 0,062% respecto a lo originalmente informado.

Como parte de la presente adenda se realizó un análisis de los impactos emergentes de dicha incorporación. En este análisis se identificaron cuatro nuevos impactos sobre los subfactores afectados de los cuales tres fueron calificados como negativos (sobre flora, fauna y erosión, edafología y ruidos molestos al vecindario), y el restante fue calificado como positivo (infraestructura eléctrica).

Dado que los impactos emergentes negativos presentan afectación baja, sólo se ha sugerido la incorporación al Plan de Gestión Ambiental una medida preventiva

| | | |
|---|--|---|
|  | Adenda - Estudio de Impacto Ambiental Parque Eólico Villalonga I Planta almacenamiento de Energía y LMT de vinculación |  |
| Cliente. GENNEIA S.A. | EIA PEVI 001-25 Adenda | |
| Autor. Scudelati & Asociados S.A. | www.scudelati.com | |

relacionada con potenciales contingencias generadas ante el incendio de la instalación como parte del Plan de Contingencias.

| | | |
|---|--|---|
|  | Adenda - Estudio de Impacto Ambiental Parque Eólico Villalonga I Planta almacenamiento de Energía y LMT de vinculación |  |
| Cliente. GENNEIA S.A. | | EIA PEVI 001-25 Adenda |
| Autor. Scudelati & Asociados S.A. | | www.scudelati.com |

2. INFORMACIÓN GENERAL

2.1. DATOS DEL PROPONENTE

Razón Social. GENNEIA S.A.

CUIT. 30-66523411-4

Domicilio Legal. Complejo Olivos Building II, Nicolás Repetto 3676 3er piso

Localidad. Vicente López

Provincia. Buenos Aires

CP. B1636CTJ

Teléfono. +54 11 6090-3200 / +54 11 6090-3201



Representante legal. Fernando Resende



E-mail. medio.ambiente@genneia.com.ar / dolores.carniglia@genneia.com.ar

2.2. DATOS DEL RESPONSABLE PROFESIONAL

La presente Adenda fue elaborada por la **Licenciada en Ciencias Biológicas María Laura Muñoz Cadenas (Registro Único de Profesionales Ambientales RUP-000436)**, quien lideró el equipo de Scudelati y Asociados S.A. que participó en el desarrollo del mismo.

A continuación, se presentan los profesionales que colaboraron en el desarrollo del estudio.

-  **Rueda Maximiliano. Licenciado en Ciencias Geológicas. DNI: 34.026.821.**
Apoyo en tareas de gabinete en la elaboración de contenidos del EIAS. Tareas de desarrollo de mapas, modelados y aspectos relacionados con el medio físico, perceptivo y patrimonio cultural.
-  **Scudelati, Mariela. Magister en Economía. DNI: 17.472.792.**
Aspectos relacionados con el medio socioeconómico.

| | | |
|---|--|---|
|  | Adenda - Estudio de Impacto Ambiental Parque Eólico Villalonga I Planta almacenamiento de Energía y LMT de vinculación |  |
| Cliente. GENNEIA S.A. | | EIA PEVI 001-25 Adenda |
| Autor. Scudelati & Asociados S.A. | | www.scudelati.com |



LA PLATA, lunes, 15 de septiembre de 2025.

MUÑOZ CADENAS MARIA LAURA

PRESENTE

Ref: Registro Unico de Profesionales Ambientales – Notificación de Renovación.



Sr Usuario,

En relación al trámite de referencia iniciado por Usted, cuyo expediente Provincial es **EX-2025-32673936- -GDEBA-DRYEAIMAMGP**, se le notifica que ha sido renovado el registro solicitado bajo el número **RUP - 000436** en base a los datos informados por Usted y el proceso desarrollado por este Organismo.

Obra este correo recibido por Usted, como **“certificado emitido de constancia de trámite e inscripción en el REGISTRO ÚNICO DE PROFESIONALES DEL AMBIENTE”**.

Atentamente.

Para uso interno: 66613

| | | |
|---|--|---|
|  | Adenda - Estudio de Impacto Ambiental Parque Eólico Villalonga I Planta almacenamiento de Energía y LMT de vinculación |  |
| Cliente. GENNEIA S.A. | | EIA PEVI 001-25 Adenda |
| Autor. Scudelati & Asociados S.A. | | www.scudelati.com |

3. MEMORIA DESCRIPTIVA

3.1. DENOMINACIÓN Y DESCRIPCIÓN GENERAL DEL PROYECTO

El presente Proyecto denominado “**Planta de Almacenamiento de Energía y su Línea de Media Tensión de vinculación (LMT)**” (PA Villalonga), consiste en la construcción de la PA Villalonga a ubicarse dentro del predio del PEVI, con el objetivo de asegurar el suministro de energía eléctrica a largo plazo e incentivar el abastecimiento de energía renovable y uso eficiente de la misma, logrando de esta manera, mejorar las condiciones del SADI.

La PA Villalonga contará con una potencia nominal declarada de **100 MW** en el punto de interconexión, una capacidad instalada de **400 MWh** lo cual proporcionan almacenamiento para entregar 4 horas de energía continuas a potencia continua.



A continuación, se indican las diferencias en relación a las superficies cubiertas proyectadas entre la presentación original del proyecto y posteriores adendas, y las incorporaciones a realizar por la Empresa.

3.1.1. INFORMACIÓN PRESENTADA EN EL EIA PARQUE EÓLICO VILLALONGA I

SUPERFICIE CUBIERTA PROYECTADA

El predio del PEVI se localiza sobre la Ruta Nacional N°3, a la altura del km 867, en la Provincia de Buenos Aires. Tiene una superficie de 727 ha. A continuación, se detallan las superficies afectadas:

- ☞ Superficie de plataformas: aproximadamente 2.300 m² por cada plataforma. Considerando el número de aerogeneradores, esto representa unos 34.500 m² en total, es decir, el 0,47% de la superficie del predio, aproximadamente.
- ☞ Superficie de zanjeos, se afectará una superficie de entre 7.966 m² y 17.070 m², dependiendo del tipo de zanjeo a realizar.
- ☞ Superficie a afectar para la construcción de caminos internos: aproximadamente de 61.800 m², lo que representa el 0,85% de la superficie del predio, aproximadamente.
- ☞ Superficie del edificio de operaciones: será de unos 1.311 m² y la zona de obradores y acopio de 10.000 m².
- ☞ La máxima superficie afectada asciende a aproximadamente 125.000 m², lo que representa un 1,7% de la superficie total del predio.

| | | |
|---|--|---|
|  | Adenda - Estudio de Impacto Ambiental Parque Eólico Villalonga I Planta almacenamiento de Energía y LMT de vinculación |  |
| | Cliente: GENNEIA S.A. | EIA PEVI 001-25 Adenda |
| Autor: Scudelati & Asociados S.A. | www.scudelati.com | |





Imagen 1. Localización de cada uno de los aerogeneradores del PEVI declarada en el EIA y aprobado por Resolución N° 959/18.

3.1.2. ADENDA AL EIA PEVI - PROYECTO PA VILLALONGA

SUPERFICIE CUBIERTA PROYECTADA

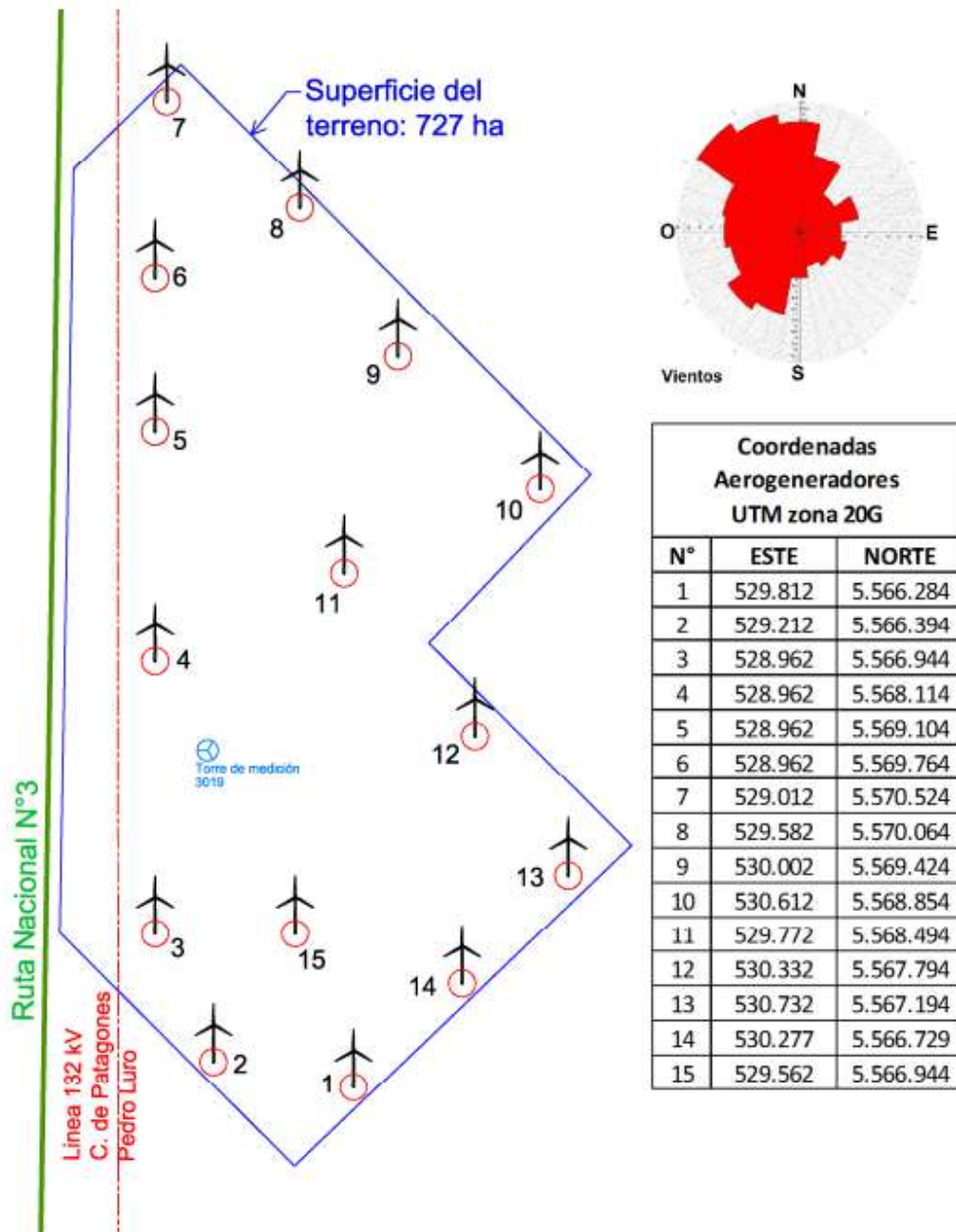
En la siguiente tabla se resume la superficie a ocupar considerando todos los factores intervinientes en la obra para el proyecto PA Villalonga.

| | | | |
|---|--|---|--|
|  | Adenda - Estudio de Impacto Ambiental Parque Eólico Villalonga I Planta almacenamiento de Energía y LMT de vinculación |  | |
| | Cliente. GENNEIA S.A. | EIA PEVI 001-25 Adenda | |
| | Autor. Scudelati & Asociados S.A. | www.scudelati.com | |



| Obra | Superficie afectada | | % de ocupación |
|---|---------------------|--------------|----------------|
| | (m ²) | (has) | |
| Caminería | 2.640 | 0,264 | 0,036% |
| Baterías | 1.320 | 0,132 | 0,018% |
| CTS | 330 | 0,033 | 0,005% |
| Edificios | 40 | 0,004 | 0,001% |
| Tendido soterrado de LMT de vinculación | 200 | 0,010 | 0,003% |
| Total Afectado por la Planta | 4.530 | 0,453 | 0,062% |
| Área total de la propiedad | 7.270.000 | 727 | |

Tabla 1. Resumen de superficie ocupada.
Fuente. GENNEIA S.A.

A continuación, se muestra el Layout donde se ubicará la futura PA Villalonga.



Figura 1. Ubicación del proyecto (PA Villalonga).
Fuente. GENNEIA S.A.

| | | | |
|---|--|---|--|
|  | Adenda - Estudio de Impacto Ambiental Parque Eólico Villalonga I Planta almacenamiento de Energía y LMT de vinculación |  | |
| | Cliente. GENNEIA S.A. | EIA PEVI 001-25 Adenda | |
| | Autor. Scudelati & Asociados S.A. | www.scudelati.com | |

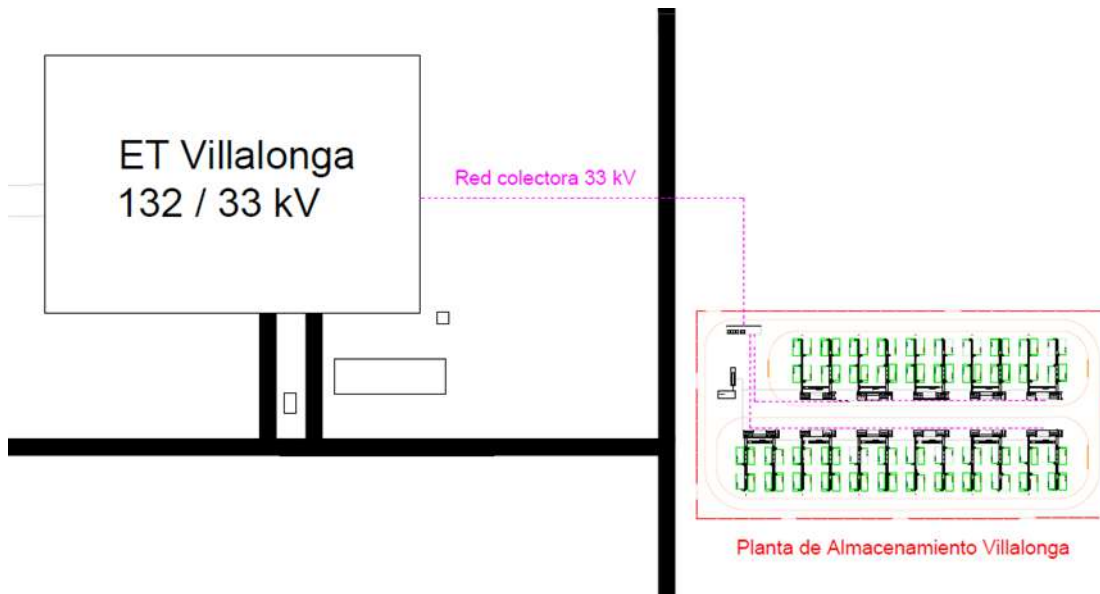

**Imagen 2. Layout PA Villalonga respecto a la ET existente.
Fuente. GENNEIA S.A.**

En la siguiente tabla se detallan las coordenadas geográficas de ubicación del PA Villalonga.

| Latitud | Longitud |
|---------------|---------------|
| 40° 1'49,17"S | 62°39'29,17"O |



Tabla 2. Coordenadas centrales de ubicación de la PA Villalonga.

La interconexión de la PA Villalonga se materializará a través de una línea de media tensión **soterrada** que se conectará al tren de celdas de 33 kV ubicado dentro del edificio de celdas del parque eólico, propiedad de GENNEIA S.A.

3.2. DESCRIPCIÓN DETALLADA DE LOS EQUIPOS

Como se mencionó anteriormente, la PA Villalonga contará con una potencia nominal declarada de **100 MW** en el punto de interconexión, una capacidad instalada de **400 MWh** lo cual proporcionan almacenamiento para entregar 4 horas de energía continuas a potencia continua.

El modo de operación tendrá como objetivo el desplazamiento de energía, para lo cual tomará energía para la carga en momento de baja demanda del nodo y entregará en

| | | |
|---|--|---|
|  | Adenda - Estudio de Impacto Ambiental Parque Eólico Villalonga I Planta almacenamiento de Energía y LMT de vinculación |  |
| | Cliente. GENNEIA S.A. | EIA PEVI 001-25 Adenda |
| Autor. Scudelati & Asociados S.A. | | www.scudelati.com |

momentos de alta demanda, procedimiento que estará operado y regulado por el OED (CAMMESA SA).

| DATOS DEL PROYECTO | |
|----------------------------|---------------|
| Potencia Instalada [MW] | 100 |
| Energía [MWh] | 400 |
| Horas de inyección | 4 |
| Punto de Conexión a la Red | ET Villalonga |
| Tensión de interconexión | 33 kV |

Tabla 3. Resumen de datos del Proyecto.
Fuente. GENNEIA S.A.

3.2.1. FUNCIONAMIENTO BÁSICO

El conjunto Planta de Almacenamiento tiene distintas funcionalidades, entre las cuales se destacan:

-  Desplazamiento de energía (peakshaving o Energy shifting). La planta podrá almacenar energía durante los periodos de baja demanda, en los cuales la red de transmisión tiene la capacidad de proveer energía. En el momento que el OED (CAMMESA) detecte que la demanda sobrepasará los límites de la red de transmisión o bien fuera del horario de generación renovable, la planta entregará energía para evitar que la red de transmisión supere la capacidad. Esta energía podrá abastecer hasta 4 horas continuas a máxima potencia.









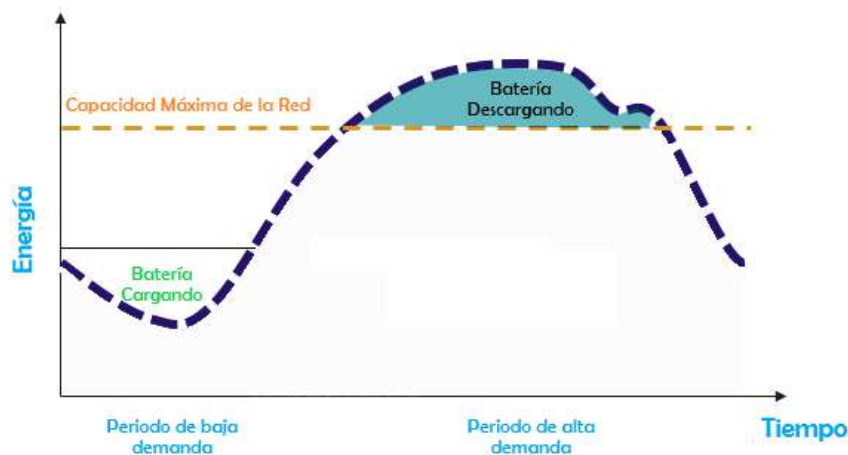

Figura 2. Curva de funcionamiento.
Fuente. GENNEIA S.A.

| | | |
|---|--|---|
|  | Adenda - Estudio de Impacto Ambiental Parque Eólico Villalonga I Planta almacenamiento de Energía y LMT de vinculación |  |
| | Cliente. GENNEIA S.A. | EIA PEVI 001-25 Adenda |
| Autor. Scudelati & Asociados S.A. | www.scudelati.com | |

- 
 Puede dar servicios adicionales a la red, tal como regular tensión, mejorando el perfil de tensión admisible de los nodos del área y evitando la necesidad de generación forzada logrando asimismo una reducción de las transferencias por las líneas de transmisión del área.
- 
 Regulación de Frecuencia.
- 
 Entrega de energía activa o reactiva.
- 
 Reserva rotante.
- 
 Arranque en negro (blackstart).

3.2.2. CICLADO, DEGRADACIÓN Y VIDA ÚTIL

Para la tecnología actual, contemplando 180 ciclos anuales, la vida útil de la batería podría superar los 20 años de vida útil, manteniendo hasta un 70% capacidad de almacenamiento.

| SOC average | 0.25C | 0.33C | 0.5C |
|-----------------------|------------|------------|------------|
| | 50% | 50% | 50% |
| DOD | 1 | 1 | 1 |
| Ambient temperature | below 40°C | below 40°C | below 40°C |
| Number of cycles/year | 365 | 365 | 365 |
| Year | 2014 | 2014 | 2014 |
| 0 | 100.00% | 100.00% | 100.00% |
| 1 | 94.89% | 94.69% | 94.27% |
| 2 | 92.71% | 92.45% | 91.86% |
| 3 | 90.96% | 90.68% | 89.97% |
| 4 | 89.38% | 89.09% | 88.28% |
| 5 | 87.91% | 87.61% | 86.69% |
| 6 | 86.52% | 86.19% | 85.17% |
| 7 | 85.18% | 84.84% | 83.71% |
| 8 | 83.88% | 83.52% | 82.29% |
| 9 | 82.63% | 82.25% | 80.92% |
| 10 | 81.40% | 81.01% | 79.57% |
| 11 | 80.21% | 79.79% | 78.24% |
| 12 | 79.05% | 78.60% | 76.95% |
| 13 | 77.89% | 77.42% | 75.67% |
| 14 | 76.75% | 76.27% | 74.41% |
| 15 | 75.64% | 75.13% | 73.16% |
| 16 | 74.54% | 74.01% | 71.93% |
| 17 | 73.45% | 72.90% | 70.72% |
| 18 | 72.38% | 71.80% | 69.52% |
| 19 | 71.32% | 70.72% | 68.33% |
| 20 | 70.28% | 69.65% | 67.14% |







Figura 3. Curva de Degradación estimada.
Fuente. GENNEIA S.A.

3.2.3. DESCRIPCIÓN DE LOS EQUIPOS PRINCIPALES

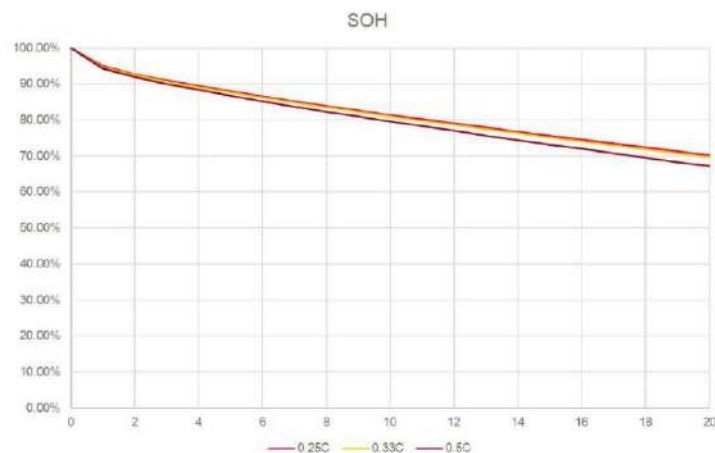
El sistema de almacenamiento estará compuesto por el almacenamiento y las instalaciones de potencia necesarias para poder cargar y descargar las baterías. Se describen a continuación ambos equipos:

- 
Almacenamiento: Son contenedores con una capacidad modular de almacenamiento. Están compuestos por 6 racks independientes de baterías de ion-litio, integrados en una envolvente de tipo contenedor de tamaño estándar (container de 6 metros de alto).

| | | |
|---|--|---|
|  | Adenda - Estudio de Impacto Ambiental Parque Eólico Villalonga I Planta almacenamiento de Energía y LMT de vinculación |  |
| | Cliente. GENNEIA S.A. | EIA PEVI 001-25 Adenda |
| Autor. Scudelati & Asociados S.A. | | www.scudelati.com |

Electrónica de Potencia (PCS). son inversores de corriente, que convierten la DC de las baterías en AC compatible con la red para poder inyectar o viceversa para poder cargar las baterías. Además de estos equipos, generalmente tienen un transformador de AC de Baja a Media tensión para compatibilizar el nivel de tensión con lo requerido en el punto de interconexión (ET). Estos también vienen en contenedores estándar (contenedor de 6 metros de alto).





Figura 4. Esquema de equipamiento.
Fuente. GENNEIA S.A.

3.2.4. ALMACENAMIENTO – BATERÍAS DE ION-LITIO

Un contenedor de baterías está conformado por strings conectados en serie/paralelo.

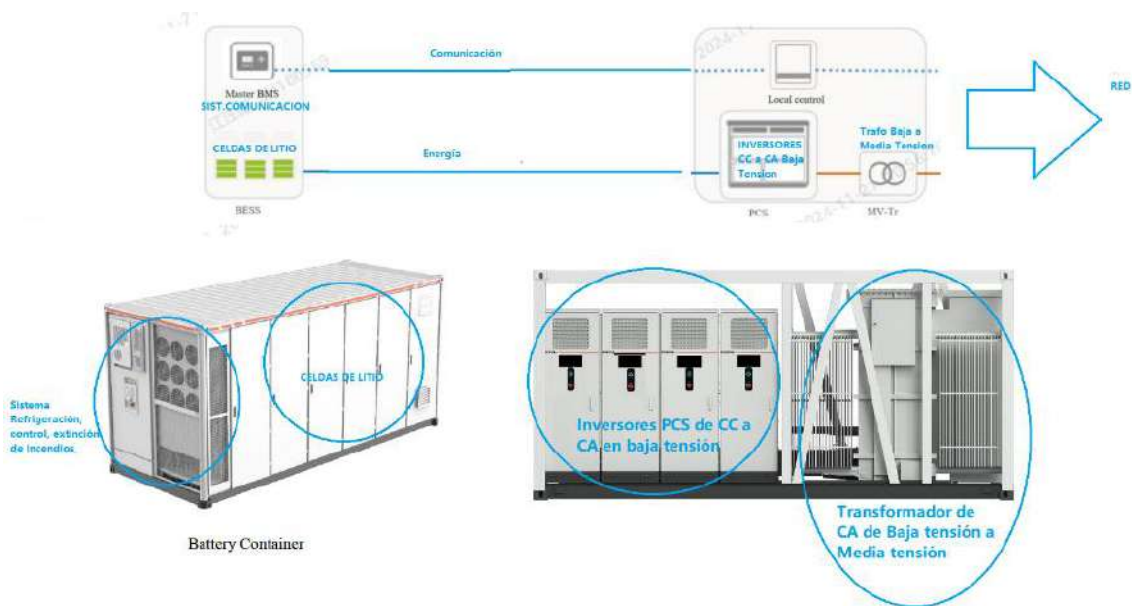

Figura 5. Módulo de baterías.
Fuente. GENNEIA S.A.

| | | | |
|---|--|------------------------|---|
|  | Adenda - Estudio de Impacto Ambiental Parque Eólico Villalonga I Planta almacenamiento de Energía y LMT de vinculación | |  |
| | Ciente. GENNEIA S.A. | EIA PEVI 001-25 Adenda | |
| Autor. Scudelati & Asociados S.A. | | | www.scudelati.com |

Está compuesto por los siguientes elementos:

- ✦ Un sistema de administración de energía (EMS), que monitorizará el estado de las baterías y definirá la operación del sistema. Será responsable de estimar el estado de carga de las baterías, controlar la carga/descarga y gestionar el estado del sistema, que incluye la gestión de la temperatura, de las protecciones y de la comunicación con otros elementos del sistema de baterías.
- ✦ Un sistema HVAC, que asegurará que las baterías trabajan bajo las condiciones de temperaturas deseadas.
- ✦ Un sistema de extinción de fuego capaz de extinguir cualquier propagación de fuego dentro del contenedor de baterías, que contiene 2 niveles de protección:
 - i. Alerta Activa: un sistema de alerta remota en tiempo real, con alarma de anomalías en cambio de temperatura y funcionamiento a nivel celda. Sistema que también sirve para operar y mantener proactivamente el pack de celdas.
 - ii. Un sistema activo de supresión de fuego bajo gas (interno al contenedor e independiente por rack) que consiste en un cartucho de gas no combustible que, ante ciertas condiciones de temperatura o alerta, se abre, desplazando el oxígeno del contenedor con el objetivo de apagar el fuego. Se adjuntan las especificaciones técnicas en el Anexo 02.



| | | |
|---|---|---|
|  | <p style="text-align: center;">Adenda - Estudio de Impacto Ambiental Parque Eólico Villalonga I Planta almacenamiento de Energía y LMT de vinculación</p> |  |
| <p>Cliente. GENNEIA S.A.</p> | <p style="text-align: right;">EIA PEVI 001-25 Adenda</p> | |
| <p>Autor. Scudelati & Asociados S.A.</p> | <p style="text-align: right;">www.scudelati.com</p> | |



Imagen 3. Sistema activo de supresión de fuego bajo gas.



TECNOLOGÍA DE LOS MÓDULOS DE BATERÍAS DE ION LITIO

Tipo de celda. El proyecto emplea celdas de batería de litio-ferrofosfato (LiFePO₄) de alto rendimiento, desarrolladas especialmente para aplicaciones de almacenamiento de energía estacionario. Esta tecnología ha sido diseñada con un enfoque prioritario en la seguridad, confiabilidad, optimización de costos y una vida útil extendida, lo que la convierte en una solución robusta y adecuada para almacenamiento a gran escala y de larga duración.

Configuración de los módulos. Los módulos de batería vienen en formato container de 20 pies. El diseño es modular y está integrado por:



- 🔧 Pack de baterías: cada pack está compuesto de celdas de baterías.
- 🔧 Rack: es con conjunto de varios Packs (generalmente 8) que se distribuyen de forma vertical formando una torre de 8 packs de baterías.
- 🔧 Contenedor con 6 racks generalmente dentro, los sistemas de comunicación, control, y seguridad.

Sistema de gestión (BMS). La gestión y protección de celdas se da con el BMS. El mismo está distribuido a nivel de pack y cluster-level management que hace balanceo

| | | | |
|---|--|---|--|
|  | Adenda - Estudio de Impacto Ambiental Parque Eólico Villalonga I Planta almacenamiento de Energía y LMT de vinculación |  | |
| | Cliente. GENNEIA S.A. | EIA PEVI 001-25 Adenda | |
| | Autor. Scudelati & Asociados S.A. | www.scudelati.com | |

y monitoreo en tiempo real, y protección por sobre/ bajo voltaje, sobrecorriente, temperatura y fallas de comunicación. Permite RTE mejorada y diagnósticos en línea.

Modos de operación. El sistema funciona en tres modos principales: carga, descarga y espera:

-  En el modo de carga, el sistema extrae energía de la red para cargar las unidades de batería, con el sistema de conversión de energía (PCS) funcionando como rectificador.
-  En el modo de descarga, las baterías suministran energía a la red y el PCS funciona como inversor.
-  Durante el modo de espera o inactivo, aunque no hay intercambio de energía, el sistema permanece activo: el sistema de refrigeración sigue funcionando y el sistema de gestión de baterías (BMS) supervisa continuamente los parámetros internos clave para garantizar la seguridad y la disponibilidad.



Cuando se emiten los puntos de ajuste, el controlador de la planta de energía (PPC) mide los valores en tiempo real en el punto de interconexión (POI), los procesa y envía comandos precisos para controlar la potencia activa y reactiva según sea necesario para cumplir con los requisitos del operador de la red.

El sistema alcanza un tiempo de respuesta de ≤ 1 segundo, definido como el tiempo entre la recepción de un punto de ajuste y el alcance del 90% de la potencia solicitada.



Figura 6. Sistema de gestión (BMS).

Especificaciones técnicas. Se adjuntan en el Anexo 03.

| | | |
|---|--|---|
|  | Adenda - Estudio de Impacto Ambiental Parque Eólico Villalonga I Planta almacenamiento de Energía y LMT de vinculación |  |
| | Cliente. GENNEIA S.A. | EIA PEVI 001-25 Adenda |
| Autor. Scudelati & Asociados S.A. | www.scudelati.com | |



3.2.5. ELECTRÓNICA DE POTENCIA – CONTENEDORES PCS-TRANSFORMADORES

El contenedor PCS-transformador convierte la corriente continua alojada en las baterías en corriente alterna y viceversa. Además, eleva la baja tensión de las baterías a media tensión para su interconexión y viceversa. Está compuesto por los siguientes elementos:

- ✦ Una o varias etapas de conversión de energía de DC a AC, cada una equipada con un sistema de control de tensión.
- ✦ Componentes de protección contra altas temperaturas de trabajo, sobre o baja tensión, sobre o subfrecuencias, corriente de funcionamiento mínima, falla de red del transformador, protección anti-isla, comportamiento contra brechas de tensión, etc. En forma complementaria cuenta con las protecciones para la seguridad laboral del personal.
- ✦ Un sistema de monitorización, que tiene la función de transmitir datos relacionados con la operación del inversor al propietario (corriente, tensión, alimentación, etc.).
- ✦ Un transformador de potencia de media tensión.



**Figura 7. Contenedor PCS-transformador.
Fuente. GENNEIA S.A.**

| | | |
|---|--|---|
|  | Adenda - Estudio de Impacto Ambiental Parque Eólico Villalonga I Planta almacenamiento de Energía y LMT de vinculación |  |
| Cliente. GENNEIA S.A. | EIA PEVI 001-25 Adenda | |
| Autor. Scudelati & Asociados S.A. | www.scudelati.com | |

3.3. ETAPAS DEL PROYECTO Y CRONOGRAMA

La construcción e instalación del Proyecto tendrá un plazo de realización aproximado de 11 meses. A continuación, se presenta el cronograma tentativo para la etapa de construcción.

| Área | N° | Tarea | año 1 | | | | | | | | | | | | | |
|-----------------------------|----|--------------------------------------|-------|---|---|---|---|---|---|---|---|----|----|----|---|--|
| | | | 1 | 2 | 3 | 4 | 5 | 6 | 7 | 8 | 9 | 10 | 11 | 12 | | |
| Abastecimiento e Ingeniería | 1 | Gestión de abastecimiento | x | x | x | | | | | | | | | | | |
| | 2 | Suministros BESS | x | x | x | x | x | x | x | | | | | | | |
| | 3 | Ingeniería de detalle | x | x | x | x | x | x | x | | | | | | | |
| Obra Civil | 4 | Movilización | | | | x | | | | | | | | | | |
| | 5 | Desbroce y nivelación parcelas | | | | x | x | x | | | | | | | | |
| | 6 | Viales y obras hidráulicas | | | | | | | x | x | x | x | | | | |
| Obra Eléctrica PS | 13 | Zanjeo y tendido redes colectoras | | | | | | | x | x | x | x | x | | | |
| | 14 | Montaje electromecánico y conexiones | | | | | | | | | | x | x | x | | |
| | 15 | Pre-Comisionamiento | | | | | | | | | | | | | x | |
| COD | 17 | Habilitación Comercial | | | | | | | | | | | | | ♦ | |

Gráfico 1. Cronograma estimado fase construcción
Fuente. GENNEIA S.

3.4. ETAPA DE CONSTRUCCIÓN

3.4.1. OBTENCIÓN DE PERMISOS Y DIVULGACIÓN DEL PROYECTO



Como permiso vinculado en gestión de obtención se encuentra la licencia de construcción que se tramita en la Dirección de Planeamiento y Desarrollo Urbano (DPDU).

La difusión del proyecto se realizará en el marco de los procedimientos de comunicación que posee GENNEIA S.A.

3.4.2. CONTRATACIÓN DE EQUIPOS, SUMINISTROS, MAQUINARIA Y VEHÍCULOS

La contratación de equipos, suministros, maquinaria y vehículos es una etapa previa a las obras de construcción.

Se formalizarán los contratos y se requerirá a las empresas contratistas sus programas de salud, seguridad ocupacional y gestión ambiental, así como cualquier requerimiento que soliciten las autoridades locales y/o provinciales.

| | | |
|---|--|---|
|  | Adenda - Estudio de Impacto Ambiental Parque Eólico Villalonga I Planta almacenamiento de Energía y LMT de vinculación |  |
| Cliente. GENNEIA S.A. | | EIA PEVI 001-25 Adenda |
| Autor. Scudelati & Asociados S.A. | | www.scudelati.com |

3.4.3. CONTRATACIÓN DE MANO DE OBRA DIRECTA

La obra de construcción de la planta demandará una contratación directa de mano de obra en un rango de 20 y 80 personas de la región conforme a las capacidades técnicas requeridas por el proyecto.

Este personal será parte de un plan de capacitación en los aspectos técnicos de cada una de las labores, las acciones de tipo ambiental y los procedimientos del plan de emergencias.

3.4.4. ADECUACIÓN DEL ÁREA



Preparación de la superficie. La parcela quedará libre de obstáculos para la correcta evolución del proyecto. Las principales tareas y aspectos a tener en cuenta para la preparación del terreno serán:

- ▣ Verificación de la nivelación del terreno (antes utilizado para ubicación de las instalaciones temporales).
- ▣ Remoción de especies de vegetación que hayan surgido en el proceso de revegetación natural.

3.4.5. INSTALACIONES TEMPORALES

Para la ubicación de las instalaciones temporales se priorizarán áreas ya afectadas para tal fin para la construcción del parque eólico. Una vez finalizadas las tareas de construcción serán retiradas. Las instalaciones contarán con el siguiente equipamiento:

| Instalaciones temporales | Descripción |
|---|---|
| Obradores | Oficinas técnicas y de administración |
| | Baños y vestidores |
| | Sistema de provisión de agua potable |
| | Estacionamientos de vehículos livianos |
| | Acopio de materiales de construcción |
| | Taller de trabajo |
| Zonas de acopio de materiales | Sistema de generación de energía eléctrica |
| | Área almacenamiento de insumos y equipos |
| Recinto de residuos y carga de combustibles | Estacionamiento de maquinarias |
| | Acopio de residuos domiciliarios |
| | Acopio de residuos peligrosos y no peligrosos |

| | | |
|---|--|---|
|  | Adenda - Estudio de Impacto Ambiental Parque Eólico Villalonga I Planta almacenamiento de Energía y LMT de vinculación |  |
| Cliente. GENNEIA S.A. | EIA PEVI 001-25 Adenda | |
| Autor. Scudelati & Asociados S.A. | www.scudelati.com | |

| Instalaciones temporales | Descripción |
|--------------------------|---|
| | Área de carga de combustibles |
| Frente de trabajo | Baños químicos y suministro de agua potable |

Tabla 4. Descripción de las instalaciones temporales.

3.4.6. CIMENTACIÓN, OBRA CIVIL Y DE URBANISMO

Camino de acceso. Para un adecuado acceso a la planta, se ejecutará un vial de acceso tipo ripio mejorado de unos 30 m entre los existentes en el parque eólico y la PA.



Cerco perimetral. Estará constituido por un vallado continuo instalado a lo largo de todo el perímetro de la planta y el mismo tendrá 2,0 m de altura mínima con alambre superior de púa, tipo cerco olímpico. Contará con dos portones de acceso.

Cimentaciones. Todas las cimentaciones de edificios y estructuras deben cumplir con los requerimientos del análisis estructural basado en los resultados obtenidos del estudio del terreno.

La empresa contratista de obra será la responsable de realizar la excavación para la cimentación de los centros de conversión/transformación. La profundidad de estas excavaciones podrá ser aproximadamente 0,60 a 0,70 m (dependiendo del tipo de cabinas). El contratista ejecutará la excavación de acuerdo con la información proporcionada por el fabricante, pero como referencia se puede considerar 12,50 x 2,50 m.

Para la construcción de fundaciones de los distintos elementos del proyecto, se considerarán las siguientes características:

- 🔧 Caseta de media tensión. Se considerará el montaje sobre apoyos de hormigón, conformado por apoyos de amarre nivelados, de acuerdo con los requerimientos propios de la instalación.
- 🔧 Módulos de baterías y electrónica de potencia. Se montarán sobre bases de hormigón armado, conformado por apoyos de amarre nivelados, de acuerdo con los requerimientos propios de la instalación.

| | | | |
|---|--|------------------------|---|
|  | Adenda - Estudio de Impacto Ambiental Parque Eólico Villalonga I Planta almacenamiento de Energía y LMT de vinculación | |  |
| | Cliente. GENNEIA S.A. | EIA PEVI 001-25 Adenda | |
| Autor. Scudelati & Asociados S.A. | | | www.scudelati.com |

3.4.7. RED INTERNA

Las canalizaciones por donde pasará el cableado contarán de un lecho de arena tamizada en la parte inferior donde se ubicarán los cables directamente enterrados, así como por encima de ellos. Para rellenar las zanjas se utilizará relleno nativo (materiales procedentes de la excavación) y se compactarán para que coincida con las condiciones existentes del terreno. Los elementos de la estructura serán transportados al emplazamiento asegurando que no serán dañados, el montaje será ejecutado de acuerdo con los manuales del fabricante los cuales explican todos los aspectos para tener en cuenta durante el proceso.

El montaje incluirá elementos resistentes a la corrosión y además se instalará una protección catódica para evitar la corrosión debida al contacto de diferentes materiales de módulos y estructuras de soporte. Todas las estructuras se conectarán correctamente al sistema de puesta a tierra. En lo que respecta a las pruebas las mismas se realizaran a todos los elementos y equipos que componen la planta y sus obras complementarias.

3.4.8. MALLA DE PUESTA A TIERRA

En cada una de las estructuras de la línea eléctrica, se instalará una malla de puesta a tierra la que será construida con acero galvanizado y chicotes de conexión entre la malla de tierra y la estructura. La unión será mediante soldadura eléctrica al stub de cada estructura. La malla a tierra será enterrada aproximadamente a 0,6 m. Además, los postes de hormigón armado tendrán en su interior una tubería de PVC de 3/4" de diámetro, para conectar a través de un cable las crucetas y bases de aisladores line post, con la puesta a tierra de la estructura.

3.4.9. CENTRO DE CONTROL

Se utilizará el centro de control del parque actualmente operativo.

3.4.10. INTERCONEXIÓN ELÉCTRICA

Como ya se indicó, la PA Villalonga estará conectada a la ET mencionada mediante una línea de media tensión soterrada, parte del centro de seccionamiento de la planta y acometerá al tren de celdas de 33 kV de la ET.



| | | |
|---|--|---|
|  | Adenda - Estudio de Impacto Ambiental Parque Eólico Villalonga I Planta almacenamiento de Energía y LMT de vinculación |  |
| | Cliente. GENNEIA S.A. | EIA PEVI 001-25 Adenda |
| Autor. Scudelati & Asociados S.A. | www.scudelati.com | |



Imagen 4. Ubicación PA Villalonga (polígono blanco) y la LMT de vinculación (traza azul).

3.5. ETAPA DE OPERACIÓN Y MANTENIMIENTO

Durante esta etapa será fundamental el plan de mantenimiento según la recomendación del fabricante, y la normativa vigente.

La generación de residuos de O&M es mínima (filtros de aire mayormente) y se enmarcará en el actual procedimiento de gestión de residuos.



El personal que opera el actual parque eólico tomará la operación de la PA.

3.6. ETAPA DE ABANDONO

El plan de cierre y desmantelamiento contempla el retiro progresivo de componentes y en especial la gestión ambiental de los residuos de baterías.

Retiro de instalaciones y gestión de residuos.

Se realizarán tareas demoliendo las bases de los contenedores y retiro de la red de distribución de energía (cables). Los residuos de obra serán dispuestos donde lo indique la autoridad ambiental local como material de relleno. El scrap metálico podrá ser enviado a empresas que lo utilizan como materia prima para sus procesos de obra.

| | | |
|---|--|---|
|  | Adenda - Estudio de Impacto Ambiental Parque Eólico Villalonga I Planta almacenamiento de Energía y LMT de vinculación |  |
| Cliente. GENNEIA S.A. | EIA PEVI 001-25 Adenda | |
| Autor. Scudelati & Asociados S.A. | www.scudelati.com | |

Ambas gestiones se encuentran desarrolladas en el procedimiento de gestión de residuos que posee la empresa para el parque eólico.

De originarse residuos peligrosos, los mismos serán gestionado conforme lo indica el procedimiento de gestión de residuos que se implementa en el parque eólico.

Gestión de baterías.

La degradación de este tipo de baterías es de un 30% luego de 20 años. Esto implica que el 70% de la batería tiene la capacidad de almacenar energía, con lo cual deberá analizarse si finalizado este plazo la misma aún no puede ser utilizado en otro proyecto de similares características.

No obstante, lo antes indicado, con respecto a las baterías se acordará con el fabricante cuál es el tratamiento final del mismo y la recepción en fábrica para:

- ✦ reciclar los componentes y materiales que lo permitan.
- ✦ enviar a tratamiento / disposición final aquellos que no.

Tareas de recomposición de suelo y flora. Sobre todos los sitios intervenidos se aplicarán los procedimientos internos de la Empresa.



3.7. CONSUMO DE ENERGÍA. TIPO. CANTIDAD. CONSUMO POR UNIDAD DE TIEMPO

3.7.1. ETAPA DE CONSTRUCCIÓN Y ABANDONO

Durante las etapas de **construcción** y de **abandono** el abastecimiento de energía eléctrica será provisto por el parque eólico.

3.7.2. ETAPA DE OPERACIÓN Y MANTENIMIENTO

Durante la etapa de **operación y mantenimiento** el abastecimiento de energía eléctrica será provisto por el parque eólico.

| | | |
|---|--|---|
|  | Adenda - Estudio de Impacto Ambiental Parque Eólico Villalonga I Planta almacenamiento de Energía y LMT de vinculación |  |
| Cliente. GENNEIA S.A. | EIA PEVI 001-25 Adenda | |
| Autor. Scudelati & Asociados S.A. | www.scudelati.com | |

3.8. CONSUMO DE COMBUSTIBLE. TIPO. CANTIDAD.

3.8.1. ETAPA DE CONSTRUCCIÓN

Se requerirá de combustibles y lubricantes para la operación de los equipos de construcción. Estos insumos serán provistos por empresas de la zona. El mantenimiento del equipo móvil y maquinaria pesada, incluyendo lavado y cambios de aceite, será realizado en lugares apropiados a tal efecto (talleres, estaciones de servicio) fuera del área del proyecto, para evitar riesgos de contaminación por derrames. Se realizará almacenamiento de combustible y lubricantes en el área de las instalaciones temporales. El almacenamiento de combustibles y lubricantes se realizará en cumplimiento de la normativa vigente.

Se estima un requerimiento de combustible para las máquinas y equipos de acuerdo a la siguiente tabla:

| Consumo de combustible (m ³ /mes) | Duración fase construcción (mes) | Total consumo (m ³) |
|--|----------------------------------|---------------------------------|
| Minicargador 480l/mes | 3 meses | 1.140 |
| Retroexcavadora | 5 meses | 12.800 |
| Manipulador Telescópico 820l/mes | 8 meses | 6.560 |
| Grúa 1020 l/mes | 1 meses | 1.020 |
| Grupo electrógeno 3500l/mes | 8 meses | 28.000 |

Tabla 5. Cantidades de combustible a utilizar en el Proyecto.

Fuente. GENNEIA S.A.



3.8.2. ETAPA DE OPERACIÓN Y MANTENIMIENTO

Para la etapa de operación y mantenimiento no se requiere el uso de combustibles.

3.9. CONSUMO DE AGUA

3.9.1. ETAPA DE CONSTRUCCIÓN

Agua para consumo y servicios higiénicos. El requerimiento de agua potable para servicios higiénicos y consumo se estima en 5 L/día/persona. En base a esto, si se considera un pico de trabajadores en la etapa de **construcción** de 80 personas, los requerimientos de agua potable se estiman para el pico de la obra en 0,4 m³/día. Para consumo del personal se proveerá agua envasada (botellas/ dispenser) desde la localidad más cercana. El agua contará con los controles fisicoquímicos y bacteriológicos periódicos conforme a las normativas laborales vigentes.

| | | |
|---|--|---|
|  | Adenda - Estudio de Impacto Ambiental Parque Eólico Villalonga I Planta almacenamiento de Energía y LMT de vinculación |  |
| Cliente. GENNEIA S.A. | EIA PEVI 001-25 Adenda | |
| Autor. Scudelati & Asociados S.A. | www.scudelati.com | |

Agua para la construcción. Se requerirán un total de 1.725 m³/mes de agua necesaria para las obras. Las principales labores consistirán en actividades de compactación y abatimiento de polvo. El agua será transportada por camiones tanque para su uso directo en la obra y será provista por proveedor externo que contará con la debida autorización provincial.

3.9.2. ETAPA DE OPERACIÓN Y MANTENIMIENTO

Agua para consumo y servicios higiénicos. No se considera consumo adicional al ya informado en el EIA del parque eólico dado que no se incorporará personal adicional.

3.10. DETALLE DE MATERIA PRIMA E INSUMOS

Los principales materiales e insumos (además del combustible y agua informados en los apartados anteriores) que se requieren para la construcción del proyecto se detallan a continuación. Cabe aclarar que las cantidades son aproximadas y las mismas están sujetas a cambios a realizar cuando se formule la ingeniería de detalle.



| Material/insumo | Unidad | Cantidad |
|--------------------------|----------------|----------|
| Cable MT | M de zanja | 450 |
| Cable BT en bandeja | ml | 1.050 |
| Cable PAT | ml | 1.600 |
| Hormigón armado | m ³ | 247 |
| Cerramiento perimetral | ml | 432 |
| Contenedores de baterías | Uni | 88 |
| Contenedores CTs | Uni | 11 |

**Tabla 6. Suministros e insumos estimados para la fase de construcción.
Fuente. GENNEIA S.A.**

3.11. CANTIDAD DE PERSONAL EMPLEADO

3.11.1. ETAPA DE CONSTRUCCIÓN

La obra de construcción de la planta puede demandar una contratación directa entre 20 y 80 personas.

| | | |
|---|--|---|
|  | Adenda - Estudio de Impacto Ambiental Parque Eólico Villalonga I Planta almacenamiento de Energía y LMT de vinculación |  |
| Cliente. GENNEIA S.A. | EIA PEVI 001-25 Adenda | |
| Autor. Scudelati & Asociados S.A. | www.scudelati.com | |



3.11.2. ETAPA DE OPERACIÓN Y MANTENIMIENTO

El sitio considera presencia de personal de manera esporádica, cada vez que sea necesario un mantenimiento programado o cuando sea necesario siguiendo la modalidad del parque eólico.

Si se considera la presencia de personal de seguridad patrimonial de manera permanente (2 personas en turnos rotativos).

3.12. VIDA ÚTIL

Para la tecnología actual, contemplando 180 ciclos anuales, la vida útil de la batería podría superar los 20 años, manteniendo hasta un 70% capacidad de almacenamiento.

| | | |
|---|--|---|
|  | Adenda - Estudio de Impacto Ambiental Parque Eólico Villalonga I Planta almacenamiento de Energía y LMT de vinculación |  |
| Cliente. GENNEIA S.A. | EIA PEVI 001-25 Adenda | |
| Autor. Scudelati & Asociados S.A. | www.scudelati.com | |

4. IDENTIFICACIÓN Y VALORACIÓN DE IMPACTOS AMBIENTALES



La metodología de análisis, la identificación y valoración de los impactos ambientales ha sido desarrollado en el EIA original, contenido en el Expediente N° 2145-1076/15 Alc. 1. Considerando que el área donde se ubicará la futura PA Villalonga se encuentra dentro de dicho parque, se mantiene lo ya declarado. A continuación, se mencionan los potenciales impactos emergentes generados como consecuencia de la obra.

4.1. POTENCIALES IMPACTOS AMBIENTALES EMERGENTES

En función de lo descrito en el apartado anterior debajo se indica en formato de tabla los aspectos técnicos incorporados, el tipo de impacto generado (positivo, negativo, despreciable o nulo), la etapa del proyecto sobre la que aplica, el/los subfactor/es afectado/s y el grado de afectación (alto, medio, bajo o nulo).

| Aspectos adicionados del proyecto | Tipo de impacto | Etapas del proyecto | Subfactor/es afectado/s | Grado de afectación | Comentario |
|---|-----------------|---------------------|--|---------------------|---|
| Construcción de Planta de almacenamiento de energía y LMT de vinculación | Negativo | Construcción | Flora (estrato herbáceo), fauna y erosión. Se incrementará el área de desbroce un 0,02% . | Bajo | El área será afectada en forma leve ya que el sitio de implantación fue intervenido durante la obra del parque. |
| | Negativo | Construcción | Edafología. Se incrementará la superficie ocupada por instalaciones permanentes. | Bajo | Las acciones a desarrollar solo generarán alteración en el emplazamiento de la PA, su acceso y la LMT. |
| | Negativo | Construcción | Ruidos molestos al vecindario. Se relaciona con el movimiento de suelos, la circulación y operación de vehículos. | Bajo | Dado que no se observaron receptores en el entorno directo del área del proyecto la misma puede ser considerada como baja. |
| | Positivo | Operación | Infraestructura eléctrica. | Medio | La introducción de una alternativa de almacenamiento eléctrico a la red eléctrica conforma un impacto positivo sobre el subfactor de carácter permanente dado que otorga estabilidad al sistema en especial en los meses estivales de alta demanda. |

Tabla 7. Análisis de impactos emergentes.
Fuente. GENNEIA S.A.

| | | |
|---|--|---|
|  | Adenda - Estudio de Impacto Ambiental Parque Eólico Villalonga I Planta almacenamiento de Energía y LMT de vinculación |  |
| Cliente. GENNEIA S.A. | | EIA PEVI 001-25 Adenda |
| Autor. Scudelati & Asociados S.A. | | www.scudelati.com |

5. MEDIDAS DE CONTROL DE LOS IMPACTOS AMBIENTALES

5.1. PLAN DE GESTIÓN AMBIENTAL

Las medidas y acciones contenidas en el plan de gestión ambiental han sido desarrolladas en el EIA original, contenido en el Expediente N° 2145-1076/15 alcance 1.

5.2. PLAN DE VIGILANCIA Y CONTROL AMBIENTAL



El plan de monitoreo y control ambiental ha sido desarrollado en el EIA original, contenido en el Expediente N° 2145-1076/15 alcance 1. No se considera la incorporación de información adicional.

5.3. PLAN DE CONTINGENCIAS



El plan de contingencias ha sido desarrollado en el EIA original, contenido en el Expediente N° 2145-1076/15 alcance 1.

Solo se considera como modificatoria la potencial contingencia generada por incendio durante la operación de la planta de almacenamiento. Dado esto, se recomiendan las siguientes acciones:

- Modificación del plan de contingencia considerando los riesgos asociados.
- Implementar el sistema de prevención de incendios con sensores conforme lo indicado por el fabricante.

| | | |
|---|--|---|
|  | Adenda - Estudio de Impacto Ambiental Parque Eólico Villalonga I Planta almacenamiento de Energía y LMT de vinculación |  |
| Cliente. GENNEIA S.A. | EIA PEVI 001-25 Adenda | |
| Autor. Scudelati & Asociados S.A. | www.scudelati.com | |

6. BIBLIOGRAFÍA

-  GENNEIA S.A., 2014. Estudio de Impacto Ambiental Parque Eólico Villalonga, provincia de Buenos Aires.
-  GENNEIA S.A., 2014. Estudio de Impacto Ambiental Evacuación de energía eléctrica del Parque Eólico Villalonga, provincia de Buenos Aires.
-  GENNEIA S.A., 2025. Memoria descriptiva Planta de almacenamiento de energía Villalonga, partido de Patagones, provincia de Buenos Aires.

Vista en planta



ET Villalonga
132 / 33 kV

Red colectora 33 kV

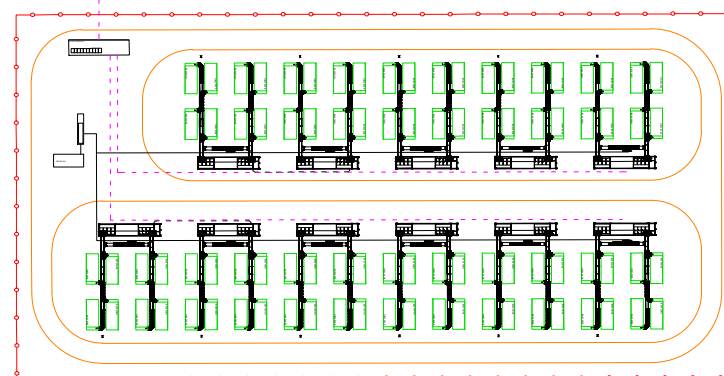

Planta de Almacenamiento Villalonga

[Signature]
Lic. MARIA LAURA MUÑOZ
RUP - 000438
DPDS

Croquis de ubicación



Acceso al parque

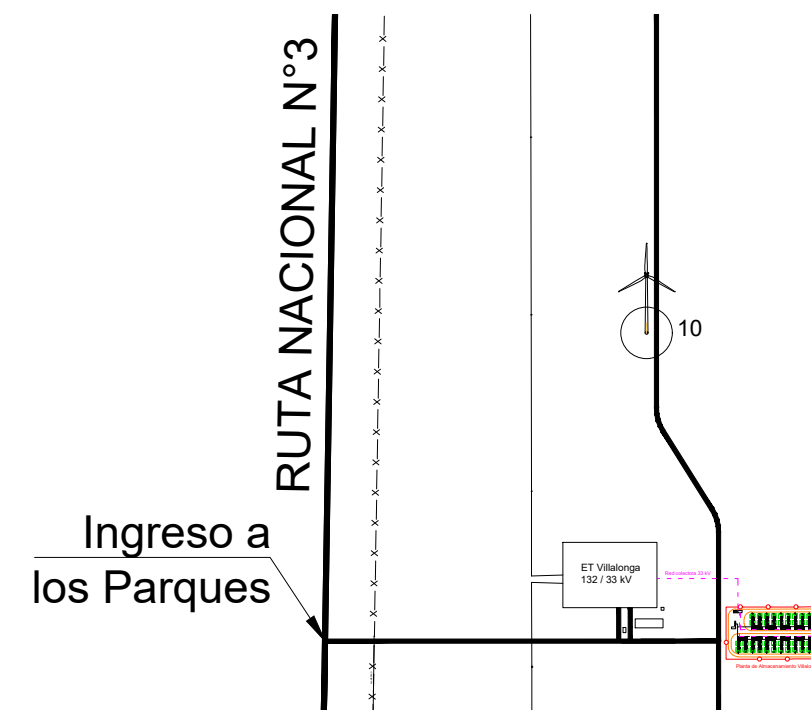

Almacenamiento BESS

ISO E Dim en mts. ESC: S/E HOJA: 1/1 REV. 2

PROYECTO:
Planta de Almacenamiento Villalonga (PAVIL)

PLANO N°
PAVIL-ANP-LY-02

ESPECIFICACIONES TÉCNICAS MÓDULOS DE BATERÍAS DE ION LITIO

| Item | TSMC5015-H-E |
|--|--|
| Battery Cabinet | |
| Battery chemistry | LFP |
| Nameplate capacity | 5015kWh |
| Nominal power | 2507.5kW(0.5P) |
| Nominal voltage (DC) | 1331.2V |
| Maximum operating voltage range (DC) | 1123.2V~1497.6 V |
| Nominal current | 1884A |
| Maximum operating current | 2232.4A |
| Main disconnecter | 1500V 3200A |
| Main fuse | 1500V 3000A |
| Fault circuit current | 106.62kA(15ms) |
| Electrical configuration | 416S12P (12 racks of 4 Modules each) |
| Power supply range | 400V ±10% |
| Operating temperature (charging/discharging) | -30~50°C |
| Operating altitude | ≤ 2000m |
| Storage temperature | -30~60°C |
| Storage humidity | 0~95% |
| Installation classification | Outdoor, Stationary, Remote Locations |
| Pollution degree | II |
| Dimensions (L*W*H) | 6058x2438 x2896 mm 20.0x8.0x9.5 ft |
| Weight | 40.5 ±2T |
| IP level | IP55 excl. chiller compartment |
| Cooling mode | Liquid cooling, 50% ethylene glycol aqueous solution |
| Fire safety | Fire panel with heat and smoke sensors |
| | Fire resistant enclosure |
| | Gas sensor and active ventilation system |
| | Automatic aerosol-based fire suppression system |
| | Water FSS |
| Communication protocols | CAN/Modbus TCP |
| Coating | C4-H (C5-H optional) |
| Color | RAL 9018 |

| | | |
|--|----------------|---|
| Design reference standards | | NFPA70 NFPA855 NFPA69 |
| Compliance | Rack | IEC 62619, IEC 63056, IEC 60730, IEC 61000, UL9540A, UL1973 |
| | Cabinet | UN 38.3, UN 3536, SDS, IEC 62477-1, IEC62933-5-2, UL 9540 |
| Module | | |
| Electrical configuration | | 1P104S |
| Dimensions (W*D*H) | | 810±3 x 2200±3 x 243±3mm |
| Protection level | | IP67 |
| Power connection | | Quick Plug |
| Compliance | Module | UN 38.3, UL9540A |
| Cell | | |
| Type | | Prismatic LFP (lithium iron phosphate) cell |
| Dimensions (D*W*H) | | 71.7±0.8mm x 174.7 ±0.8mm x 207.4±0.8mm |
| Weight | | 5.60±0.3kg |
| Nominal capacity | | 314Ah |
| Nominal charge/discharge power | | 502W |
| Nominal voltage | | 3.2V |
| Operating voltage range | | 2.0V~3.65V(t≤0°C) 2.5V~3.65V(t>0°C) |
| Charge operating cell temperature range | | 0~60°C |
| Discharge operating cell temperature range | | -30~60°C |
| SOC operating range | | 0~100% |
| Shipping SOC | | 25% |
| Compliance | Battery safety | IEC62619, UL1973, UL9540A |
| | Transportation | UN38.3 |

 Lic. MARIA LAURA MUÑOZ
 RUP-30043
 CPDS

| | | | |
|---------------|------------|-----------------|-------------|
| Number | 66031 | Replaces | --- |
| Issued | 22-12-2011 | Scope | 2004/108/EC |
| Report number | 126076 | Contract number | --- |

Certificate

Kiwa hereby declares that the **Fire extinguisher activator**, type

Activator

manufactured by **Firepro Systems Ltd**
Limasol, Cyprus

meets the essential requirements 1a and 1b as described in the **Directive on electromagnetic compatibility (2004/108/EC) for use in Light industrial and Residential environments.**

on the following phenomena (see also annex 3 of the EMC guide):

- Conducted low frequency phenomena
- Radiated low-frequency field phenomena
- Conducted high-frequency phenomena
- Radiated high-frequency field phenomena
- Electrostatic discharge phenomena (ESD)

This conformity assessment of the manufacturer's technical documents is based upon:

- use of EMC harmonised standards

Production control

- is not covered as part of this certificate

The light industrial and household environment use

a Nederland B.V.
nersdorf 50
Box 137
0 AC APELDOORN
Netherlands

www.kiwa.com

ASTEC

PRODUCTS
RVA C 002
Lic. MARIA LAURA MUÑOZ
RUP-00048
DPS

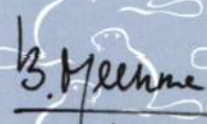
Bouke Meekma
Kiwa

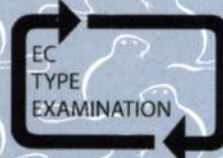
kiwa
Approved
EC Directive

2004/108/EC
CE
0063
ASTEC

Kitemark™ Certificate

This is to certify that:

FirePro Systems Ltd
8 Faleas Str.
Agios Athanasios Industrial Area
Limassol
CY-4101
Cyprus

Holds Certificate Number:

KM 738886

In respect of:

BS EN 15276
Condensed aerosol extinguishing systems

This issues the right and licence to use the Kitemark in accordance with the Kitemark Terms and Conditions governing the use of the Kitemark, as may be updated from time to time by BSI Assurance UK Ltd (the "Conditions"). All defined terms in this Certificate shall have the same meaning as in the Conditions.

The use of the Kitemark is authorized in respect of the Product(s) detailed on this Certificate provided at or from the above address.

For and on behalf of BSI:

Shahm Barhom, Group Product Certification Director

First Issued: 2021-04-14

Latest Issue: 2024-04-16

Effective Date: 2024-04-16

Expiry Date: 2027-04-13

Page: 1 of 3



Kitemark™ Certificate

No. KM 738886

| Model No | Description | Branded As |
|-----------|--|------------|
| FP-20SE | Condensed Aerosol Generator; 20g of solid aerosol forming compound, Cylinder - Stainless Steel Housing, Electrical Activation, Efficiency 60% | FirePro |
| FP-20T | Condensed Aerosol Generator; 20g of solid aerosol forming compound, Cylinder - Stainless Steel Housing, Electrical Activation, Efficiency 70% | FirePro |
| FP-20TH | Condensed Aerosol Generator; 20g of solid aerosol forming compound, Cylinder - Stainless Steel Housing, Thermal Activation, Efficiency 70% | FirePro |
| FP-40S | Condensed Aerosol Generator; 40g of solid aerosol forming compound, Cylinder - Stainless Steel Housing, Electrical Activation, Efficiency 61% | FirePro |
| FP-40T | Condensed Aerosol Generator; 40g of solid aerosol forming compound, Cylinder - Stainless Steel Housing, Thermal / Electrical Activation, Efficiency 62% | FirePro |
| FP-80S | Condensed Aerosol Generator; 80g of solid aerosol forming compound, Cylinder - Stainless Steel Housing, Electrical Activation, Efficiency 59% | FirePro |
| FP-80T | Condensed Aerosol Generator; 80g of solid aerosol forming compound, Cylinder - Stainless Steel Housing, Thermal / Electrical Activation, Efficiency 60% | FirePro |
| FP-100S | Condensed Aerosol Generator; 100g of solid aerosol forming compound, Cylinder - Stainless Steel Housing, Thermal / Electrical Activation, Efficiency 61% | FirePro |
| FP-200S | Condensed Aerosol Generator; 200g of solid aerosol forming compound, Cylinder - Stainless Steel Housing, Thermal / Electrical Activation, Efficiency 59% | FirePro |
| FP-500S | Condensed Aerosol Generator; 500g of solid aerosol forming compound, Cylinder - Stainless Steel Housing, Thermal / Electrical Activation, Efficiency 66% | FirePro |
| FP-1200 | Condensed Aerosol Generator; 1200g of solid aerosol forming compound, Box - Red Coated Steel Housing, Electrical Activation, Efficiency 63% | FirePro |
| FP-1200T | Condensed Aerosol Generator; 1200g of solid aerosol forming compound, Box - Red Coated Steel Housing, Thermal / Electrical Activation, Efficiency 63% | FirePro |
| FP-1200S | Condensed Aerosol Generator; 1200g of solid aerosol forming compound, Box - Stainless Steel Housing, Electrical Activation, Efficiency 63% | FirePro |
| FP-1200TS | Condensed Aerosol Generator; 1200g of solid aerosol forming compound, Box - Stainless Steel Housing, Thermal / Electrical Activation, Efficiency 63% | FirePro |
| FP-2000 | Condensed Aerosol Generator; 2000g of solid aerosol forming compound, Box - Red Coated Steel Housing, Electrical Activation, Efficiency 60% | FirePro |

First Issued: 2021-04-14

Latest Issue: 2024-04-16

Effective Date: 2024-04-16

Expiry Date: 2027-04-13



Page: 2 of 3

This certificate has been issued by and remains the property of BSI Assurance UK Ltd, Kitemark Court, Davy Avenue, Knowlhill, Milton Keynes MK5 8PP, United Kingdom and should be returned immediately upon request.

To check its validity telephone +44 (0) 345 080 9000. An electronic certificate can be authenticated [online](#).

Kitemark™ Certificate

No. KM 738886

| Model No | Description | Branded As |
|-----------|---|------------|
| FP-2000T | Condensed Aerosol Generator; 2000g of solid aerosol forming compound, Box - Red Coated Steel Housing, Thermal / Electrical Activation, Efficiency 60% | FirePro |
| FP-2000S | Condensed Aerosol Generator; 2000g of solid aerosol forming compound, Box - Stainless Steel Housing, Electrical Activation, Efficiency 60% | FirePro |
| FP-2000TS | Condensed Aerosol Generator; 2000g of solid aerosol forming compound, Box - Stainless Steel Housing, Thermal / Electrical Activation, Efficiency 60% | FirePro |
| FP-3000 | Condensed Aerosol Generator; 3000g of solid aerosol forming compound, Box - Red Coated Steel Housing, Electrical Activation, Efficiency 61% | FirePro |
| FP-3000T | Condensed Aerosol Generator; 3000g of solid aerosol forming compound, Box - Red Coated Steel Housing, Thermal / Electrical Activation, Efficiency 61% | FirePro |
| FP-3000S | Condensed Aerosol Generator; 3000g of solid aerosol forming compound, Box - Stainless Steel Housing, Electrical Activation, Efficiency 61% | FirePro |
| FP-3000TS | Condensed Aerosol Generator; 3000g of solid aerosol forming compound, Box - Stainless Steel Housing, Thermal / Electrical Activation, Efficiency 61% | FirePro |
| FP-4200T | Condensed Aerosol Generator; 4200g of solid aerosol forming compound, Box - Red Coated Steel Housing, Thermal / Electrical Activation, Efficiency 60% | FirePro |
| FP-4200TS | Condensed Aerosol Generator; 4200g of solid aerosol forming compound, Box - Stainless Steel Housing, Thermal / Electrical Activation, Efficiency 60% | FirePro |
| FP-5700 | Condensed Aerosol Generator; 5700g of solid aerosol forming compound, Box - Red Coated Steel Housing, Electrical Activation, Efficiency 59% | FirePro |
| FP-5700T | Condensed Aerosol Generator; 5700g of solid aerosol forming compound, Box - Red Coated Steel Housing, Thermal / Electrical Activation, Efficiency 59% | FirePro |
| FP-5700S | Condensed Aerosol Generator; 5700g of solid aerosol forming compound, Box - Stainless Steel Housing, Thermal / Electrical Activation, Efficiency 59% | FirePro |
| FP-5700TS | Condensed Aerosol Generator; 5700g of solid aerosol forming compound, Box - Stainless Steel Housing, Thermal / Electrical Activation, Efficiency 59% | FirePro |

Aerosol Generating Fire Extinguishing System Units are certified to BS EN 15276-1:2019

First Issued: 2021-04-14

Latest Issue: 2024-04-16

Effective Date: 2024-04-16

Expiry Date: 2027-04-13



Page: 3 of 3

This certificate has been issued by and remains the property of BSI Assurance UK Ltd, Kitemark Court, Davy Avenue, Knowlhill, Milton Keynes MK5 8PP, United Kingdom and should be returned immediately upon request.

To check its validity telephone +44 (0) 345 080 9000. An electronic certificate can be authenticated [online](#).



October 2, 2024

MR. IOANNIA LAMBROU
FirePro Systems Ltd.
8 Faleas Str. 4101,
Limassol, Cyprus - EU

Our Reference: File EX6960
Subject: Confirmation of Testing for UL Certified Extinguishing System Units

Dear Mr. Lambrou,

This letter is confirm the applicable testing from UL/ULC 2775 that was conducted on FirePro generator samples as part of the certification with UL to UL/ULC 2775.

The FirePro condensed aerosol generators, listed in the UL Certificate of Compliance EX6960, have been assessed and found to comply with the testing requirements specified in the following sections of the UL2775 standard:

| Test Description | Outcome |
|---|---------|
| Section 21_Discharge Test | PASSED |
| Section 22_Temperature Measurement Test | PASSED |
| Section 23_Mounting Device Test | PASSED |
| Section 24_Rough Usage Test | PASSED |
| Section 25_Vibration Test | PASSED |
| Section 26_Pyrotechnic Reaction Containment Test | PASSED |
| Section 27_Fire Exposure Test | PASSED |
| Section 28_High Humidity Test | PASSED |
| Section 29_Moist Hydrogen Sulfide Air Mixture Corrosion Test | PASSED |
| Section 30_Moist Carbon Dioxide-Sulfur Dioxide Air Mixture Corrosion Test | PASSED |

UL Solutions
333 Pfingsten Road
Northbrook
Illinois, 60062

T +1.847.272.8800

UL.com/Solutions



Lic. MARIA LAURA MUÑOZ
RUP - 000438
CPO3



| | |
|--|--------|
| Section 31_Salt Spray Corrosion Test | PASSED |
| Section 32_Thirty-Day Elevated Temperature Test | PASSED |
| Section 33_Temperature Cycling Test | PASSED |
| Section 48_500 Cycle Operation Test | PASSED |
| Section 49_Class A and B Fire Extinguishment Tests | PASSED |
| Section 50_Distribution Verification Extinguishment Tests with Extinguishing System Unit | PASSED |
| Section 55_Aging Test – Condensed Aerosol Generator | PASSED |

Please note that sections and clauses of UL/ULC 2775 that are not included in the above table were determined to not be applicable to the construction of the FirePro extinguishing system units submitted for this certification.

If you have any questions or comments, please do not hesitate to contact the undersigned.
Very truly yours,

Sincerely,

Kevin Holly
Engineer Staff
3019BFPD
Tel: 847-664-3494
kevin.hollyjr@us.ul.com

Any information and documentation involving UL Mark services are provided on behalf of UL LLC (UL) or any authorized licensee of UL.

Lic. MARIA LAURA MUÑOZ
RUP - 000438
CPES

FirePro.

INFORMATION, INSTRUCTION & USER MANUAL

Version 8 ,May 2020

Fire Extinguishing Aerosol Systems

FirePro Systems Ltd
8 Faleas Street, Agios Athanasios Industrial Area, CY-4101 Limassol, Cyprus - EU
Tel.: +357 25 379999, Fax: +357 25 354432, Email: mail@firepro.com
www.firepro.com



Reinventing
Fire Suppression

Preamble

Limited liability.

FirePro Systems Ltd. disclaims warranties or guarantees relating to the content of this document and specifically deny any guarantee relating to the marketability or suitability for any particular purpose. FirePro products are updated regularly. It is therefore possible that there will be differences in particular instructions, specifications and illustrations in this documentation. FirePro Systems Ltd. also reserve the right to revise this publication and to make changes to the content without prior notice. Under absolutely no circumstances is FirePro Systems Ltd., liable for incidental or consequential losses, including, but not limited to loss of income or other business losses arising from the use of these products.

FirePro Systems Ltd. cannot be held liable for modifications made by the user and the consequences thereof.

No liability for consequential losses

Under no circumstances is FirePro Systems Ltd. and its distributors liable for losses (including but not limited to compensation for loss of profits, business interruption, loss of business information or other pecuniary loss) arising from the use or any prevention of use of these products, even if the risk of such losses has been brought to the attention of FirePro Systems Ltd. and its distributors.

Limited guarantee

Limited manufacturer's guarantee

FirePro Systems Ltd. guarantee that FirePro products will basically function in accordance with the associated documentation.

No other guarantee

FirePro Systems Ltd. and its distributors give no other guarantee, either express or implicit, including but not limited to an implicit guarantee regarding marketability or suitability for a given purpose, in relation to FirePro products and the associated documentation.

Modifications to the product

FirePro Systems Ltd., cannot be held liable for modifications made by the user and the consequences thereof that affect the product conformity with the CE mark.

Trademarks.

FirePro is the registered trademark of Celanova Ltd. of Limassol, Cyprus. Celanova is a sister company of FirePro Systems Ltd. All other business or product names are trademarks, registered trademarks or service marks of their respective owners.

Information about regulations

European Directives

Products as referred to in this manual with the CE mark meet the Directive for stationary dry aerosol-based extinguishing components (EMC Directive 2014/30/EU). The components also meet the testing requirement BRL-K23001/05 under a certificate issued by KIWA NV under accreditation.

Copyright ©

All rights reserved. No part of this publication may be reproduced and/or published by print, photoprint, microfilm or any other means without the prior permission of FirePro Systems Ltd.

If this manual is published under order, see the General Terms and Conditions of FirePro Systems Ltd. or the relevant agreement concluded between the parties to this effect for the rights and obligations of customer and contractor. This manual may be given to directly interested parties for perusal.

Reference to the standards below is made in the above testing requirement and in this information, instruction, and user manual.

| | |
|--|--|
| NEN 5509 | : user manuals – content, structure, formulation and presentation |
| EN 82079-1 | : Preparation of instructions for use- Structuring, content and presentation |
| ISO/IEC 17065 | : Conformity assessment — Requirements for bodies certifying products, processes and services |
| ISO/IEC 17021 | : Conformity assessment — Requirements for bodies providing audit and certification of management systems |
| ISO/IEC 17024 | : Conformity assessment — General requirements for bodies operating certification of persons |
| ISO/IEC 17020 | : Conformity assessment — Requirements for the operation of various types of bodies performing inspection |
| EN ISO 14121-1:2007 | : principles for risk assessment |
| EN-54 | : Fire detection and alarm systems |
| EN-60364 | : Low Voltage Electrical Installations |
| NEN-2654 or applicable EN Standard | : management, control and maintenance of fire safety systems |
| NEN-2575 (2004) or applicable EN Standard | : fire safety of buildings – evacuation alarm installations - system and quality requirements and guidelines for locating of alarm devices |

Contents

| | |
|--|----|
| Preamble..... | 2 |
| 1 Introduction..... | 5 |
| 1.1 Foreword | 5 |
| 1.2 Normative References | 5 |
| 1.3 Safety Instructions..... | 5 |
| 1.4 Aerosol Designations | 6 |
| 1.5 Action of Aerosol Extinguishing Agent..... | 7 |
| 1.6 Certification and Testing | 8 |
| 1.7 Agreement Between the Councils for Accreditation | 10 |
| 1.8 Certification..... | 13 |
| 1.8.1 KIWA PRODUCT CERTIFICATE | 14 |
| 1.9 Declaration of Conformity | 15 |
| 1.10 Test Institutes Worldwide..... | 16 |
| 2 Purpose and Use | 17 |
| 3 Safety Measures | 18 |
| 4 Storage and Transport..... | 18 |
| 5 Design, Generators Models and Data Sheets | 19 |
| 5.1 Design | 19 |
| 5.2 Overview of Various Generator Models..... | 20 |
| 5.3 Data Sheets..... | 21 |
| 6 Risk Assessment..... | 32 |
| 7 Calculation of Amount of FirePro Required | 33 |
| 8 Preconditions in the Design of an Installation | 35 |
| 9 Activation Methods | 40 |
| 9.1 Electrical Activation..... | 41 |
| 9.2 Thermal Activation | 42 |
| 9.2.1 Methods of Thermal Activation..... | 42 |
| 10 Preparation for Installation..... | 45 |
| 10.1 General Guidelines for Installation of Fixed System | 45 |
| 10.2 General..... | 46 |
| 10.3 Emergency Fire Detection and Fire Alarm System Power Supply | 47 |
| 11 Installation Procedure | 49 |
| 11.1 Cabling/Installation..... | 50 |
| 11.2 Circuit integrity under fire conditions..... | 51 |
| 11.3 Cable Monitoring | 52 |
| 11.4 Shutdown of Energy Supply and Computers..... | 52 |
| 12 Installation, Installation Tests, Delivery, Inspection and Maintenance..... | 53 |
| 12.1 Installation | 53 |
| 12.2 Installation Tests and Delivery..... | 54 |
| 12.3 Maintenance and Inspection | 54 |
| 12.4 Drawings and Pictograms | 56 |
| 13 Residue, Removal, Dismantling of Units, Waste and Environment | 58 |
| 13.1 Residue | 58 |
| 13.2 Guidelines for the Removal of the Residue..... | 58 |
| 13.3 Dismantling | 59 |
| 13.4 Waste and Environment..... | 59 |
| 14 Safety Data Sheet – SDS..... | 60 |
| 15 Alphabetical Technical Glossary | 65 |

APPENDICES

1 Introduction

1.1 Foreword

FirePro aerosol fire extinguishers and fire extinguishing systems are designed to control and/or extinguish a fire. The authors have arranged this information, instruction and user manual so that consideration has been given to all the important aspects for a functional installation. A demonstrably functional installation of FirePro fire extinguishing systems requires this manual to be followed closely.

The information, instruction and user manual is designed for experts and consultants who are involved in any way in the design, installation, delivery and aftercare of FirePro aerosol fire extinguishers and aerosol fire extinguishing systems. The information, instruction and user manual must be used in conjunction with BRL K23001 and BRL K23003 of KIWA Certification & Inspections and in conjunction with EN 15276-1:2019 and EN 15276-2:2019 European aerosol standard and ISO 15779 international aerosol standard.

For correct interpretation the ‘Certified Authorized Technical Technician Aerosol Systems’ training (CATTAS training) or equivalent, which covers the aspects referred to in this document, must be followed as a minimum. The electrical installations referred to in this information, instruction and user manual, such as fire detection, control and alarm systems, must be installed by specially trained personnel of the supplier of the systems concerned. These aspects are not therefore covered in this information, instruction and user manual. In the event of improper use of this manual, neither manufacturer nor distributor nor dealer can bear any responsibility.















1.2 Normative References

The standards referred to in this information, instruction and user manual contain provisions, which because reference is made to them, are also provisions of this document. At the time of publication of this document the editions referred to were in force. However, all standards are subject to revision; parties concluding agreements on the basis of this document are therefore advised to check whether it is possible to apply the most recent edition of standards referred to in this document.

1.3 Safety Instructions

This information, instruction and user manual contains preventive measures and safety instructions for carrying out the necessary operations safely. The following may serve as a list of the term “operations” in the different phases of the product: transport, reception, storage, assembly, placing of product, mounting and/or installation, treatment and/or use, maintenance, visual examination, repair, decommissioning, dismantling, removal, disposal, waste, health, safety and environment.

Pictograms used for prohibitions, commands and warnings in this document are:

| | | | | | |
|-------------|---|---|---|---|---|
| PROHIBITION |  |  |  |  |  |
| | Important | Open fire prohibited | Smoking prohibited | Switch off prohibited | Switch on prohibited |
| COMMAND |  |  |  |  |  |
| | Important ! | Eye protection | Head protection | Hand protection | Disconnect |
| WARNING |  |  |  |  |  |
| | Warning | Fall risk | Hot surface | Damage | Breakable |

1.4 Aerosol Designations

The need for an explanation of the correct terms or designations and the behaviour of aerosol emerged during the development of aerosol-based extinguishing systems. In this explanation we would like to address this matter so that clearer terms can be used in for example presentations of the extinguishing system. We shall therefore consider the parts systematically.

Aerosol

An aerosol is a *colloidal dispersion* in a gas.

Aero / Sol
Air / Colloidal solution

Colloids

Particles measuring from a few micrometres (10^{-6} m) to a few nanometres (10^{-9} m) that are suspended in another substance or gas without actually being dissolved in it. If colloids are dispersed in a solution, we have a *colloidal solution* or *sol*. The solvent is called *dispersion medium* or *continuous phase*. In the case of an aerosol extinguishing agent such as FirePro the solvent is the air around us.

Dispersion

The distribution of a substance is called *dispersal* and the resulting product dispersion. A sol is consequently a colloidal dispersion in a solvent.

Potassium

Part of the solid compound of FirePro consists of potassium. Potassium is a chemical element (a very soft metal with a silvery lustre).

1. History and name

Potassium was first isolated by Davy in 1807 through the electrolysis of molten potassium hydroxide (KOH), from which the name potassium is derived (see also alkali). At roughly the same time (1807 – 1808) Gay-Lussac and Louis Jacques Thenard obtained the element through the reduction of molten potassium carbonate with iron filings in an iron crucible.

2. Occurrence

With 2.59% potassium occupies seventh place in the list of most common elements in the earth's crust. In seawater it has an average concentration of 0.380 g per kg. It can be found in very many minerals, vegetables and living organisms (plants, animals, humans, etc, contain organic potassium salts).

3. Properties

Potassium is an alkali metal. Apart from an inert gas configuration, the elements of this group, the alkali metals, have a single s electron that can easily be split off. Potassium consequently has a very simple, ionic chemistry.

4. Physiological significance in the human body

While it is mainly sodium salts (in particular ordinary kitchen salt) that are dissolved in tissue fluid, it is potassium salts that can be found in cells and not sodium. The amount of potassium in the body is connected to the amount of sodium. Therefore, potassium plays an important role for living organisms. Important sources of potassium in food are: vegetables, fruit, potatoes, meat, bread and milk. An adult needs approx. 3,500 mg of potassium per day.

1.5 Action of Aerosol Extinguishing Agent

The overview below gives a brief description of the extinguishing action of FirePro aerosol fire extinguishers and fire extinguishing systems.

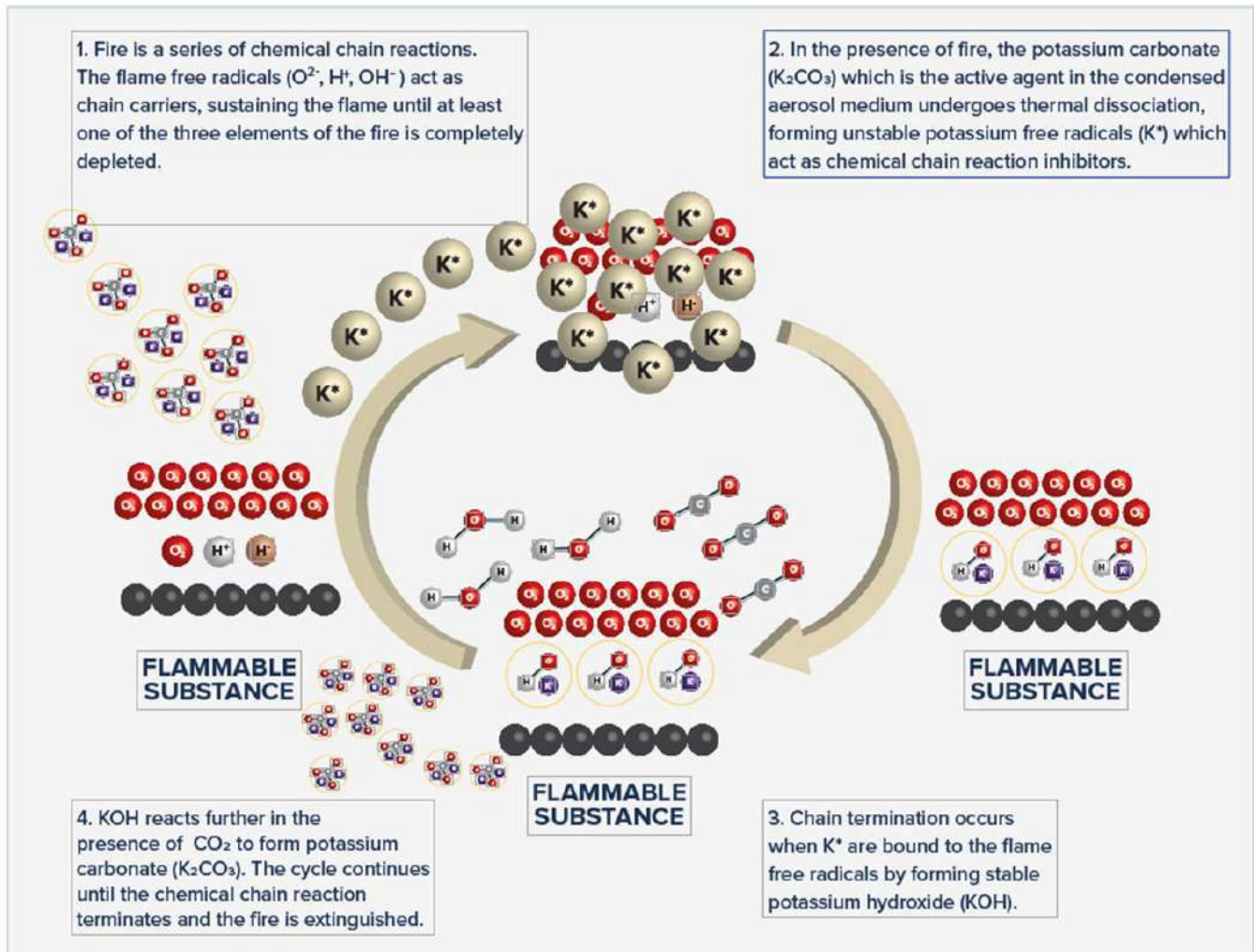

1.6 Certification and Testing

To attain certified products and processes it was decided, on the advice of the Ministry of the Interior and the European Community, to work according to *ISO/IEC* (product and process certification), *ISO/IEC17021* (system certification) and *ISO/IEC17024* (person certification). The necessary tests have been carried out in cooperation with national and international accredited bodies. The chart below shows the process steps completed.

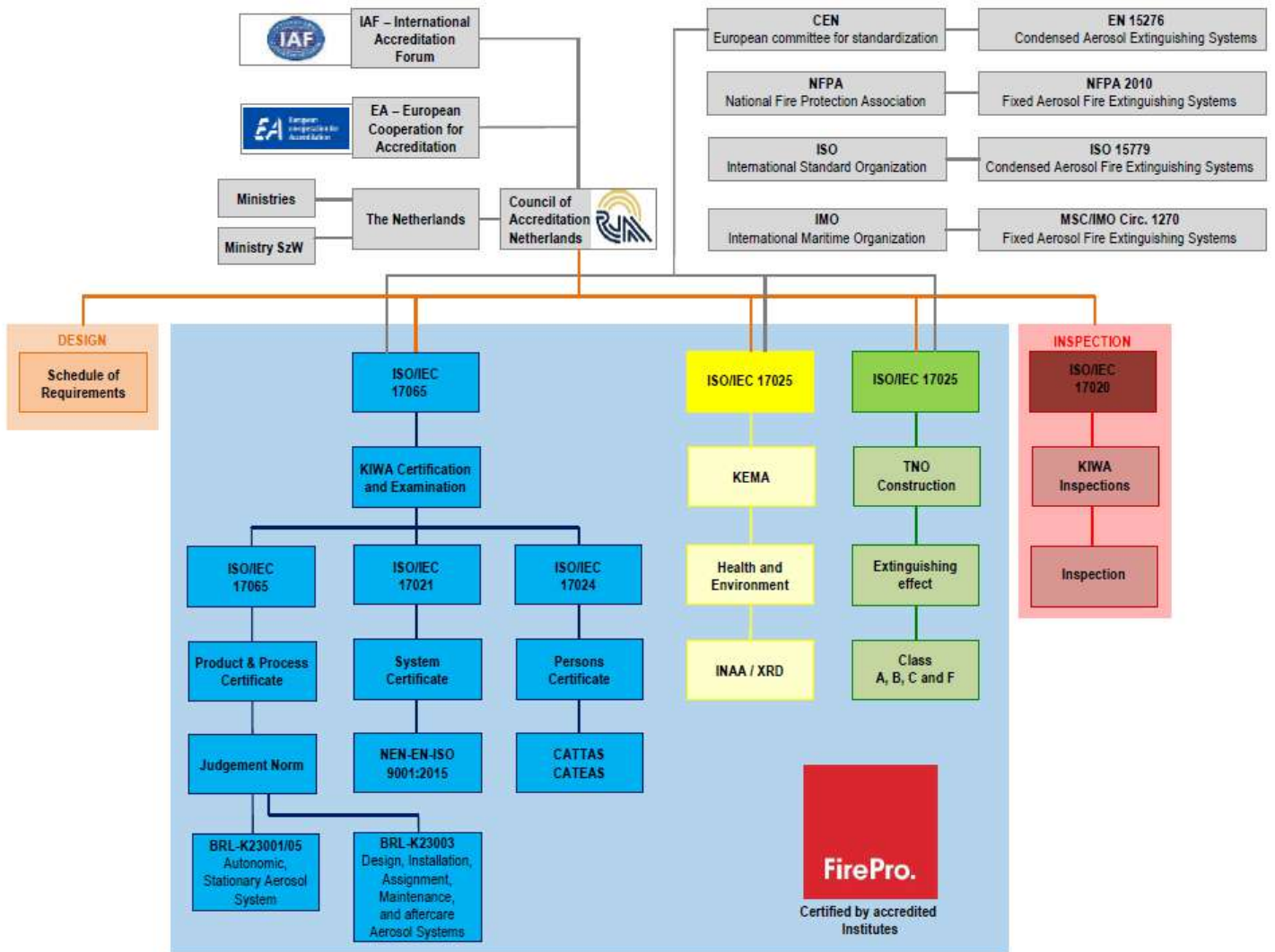

The ministries, organisations and institutes below have co-operated with the tests and/or certifications.



BSI Product Services
Kitemark House, Maylands Ave
Hemel Hempstead, HERTS HP2 4SQ
England
Tel. +44 8450 765 000



US EPA
United States Environmental Protection
Agency
Ariel Rios Bldg, 1200 Pennsylvania Ave, NW
Washington DC 20460



Ministry of Housing, Spatial Planning &
the Environment
PO Box 30945
NL - 2500 GX The Hague
Tel. +31 (0)70-339 4070



Min. of Transport, Public Works & Water
Management
Shipping Division
PO Box 8634
NL - 3009 AP Rotterdam
Tel. +31 (0)10-266 8500



Council for Accreditation
PO Box 2768
NL - 3500 GT Utrecht
Tel. +31 (0)30-239 4500



KIWA Nederland B.V.
PO Box 70
NL - 2280 AB Rijswijk
Tel. +31 (0)88-998 4400



ECB
Julianaweg 224A
NL - 1131 NW Volendam
Contact: P.A. van der Weide
Tel. +31 (0)299-323 123



KEMA Nederland E.G.
Utrechtseweg 310
NL - 6812 AR Arnhem
Tel. +31 (0)26-356 2225



Underwriters Laboratories of Canada
7 Underwriters' Rd
Toronto, ON M1R 3B4
Canada
Tel. +1 416 757 3611



TNO Bouw
PO Box 49
NL - 2600 AA Delft
Tel. +31 (0)15-284 2309



Ministero dell' Interno
Direzione Generale della protezione civile e
dei servizi antincendi
Italy



Underwriters Laboratories Inc.
333 Pflugsten Road, Northbrook,
IL 60062-2096 USA



Jednostka Certyfikująca Wzrosty
Centrum Naukowo-Badawcze Ochrony
The Józef Tułiszowski Scientific and
Research Centre for Fire Protection.



asbl ANPI vzw
Granbonpré 1
Parc scientifique Fleming
1348 Louvain-la-Neuve-Sud
Belgium
Tel. +32 (0)10-47 5243



DNV GL
Zwolsseweg 1
PO Box 9599
NL - 2994 LB Barendrecht
Tel. +31 (0)10- 292 2600



Hughes Ass. Europe, srl
Via Vincenzo Monti, 52
I - 20017 RHO (Milan)
Tel. +39 02-9390 4340



Państwowy Zakład Higieny
Instytut Naukowo-Badawczy
ul. Chocimaska 24
PL - 00-791 Warschau
Tel. +48-49-4051



Danish Maritime Authority
Sofarststyrelsen
Vermundsgade 38C
DK - 2100 Copenhagen
Tel. +45 (0)39-17 4400



The Standards Institution of Israel
42 Chaim Levanon Street
IL - Tel Aviv 69977
Tel. +972-3-646 5154



Maritime Fire Institute
DBI Dansk Brand- og Sikringsteknisk
Institut
Jernholmen 12
DK - 2650 Hvidovre
Tel. +45 (0)36-34 9000



Nationaal Lucht-en
Ruimtevaartlaboratorium
NLR Amsterdam
Anthony Fokkerweg 2
1059 CM Amsterdam
Tel. +31 20 511 3113



Commonwealth Scientific & Technical
Research Organisation
Australia
Tel. +61 3 9252 6000

1.7 Agreement Between the Councils for Accreditation

Source: www.rva.nl



The Council for Accreditation seeks the acceptance and honouring of accreditations not only nationally but also worldwide. In the case of applications for or consultation about acceptance of accreditations of other accreditation bodies, the Council for Accreditation will always take as its starting point that the accreditations must demonstrably be of equivalent quality level. This quality level is verified by means of international peer reviews. Accredited bodies receive an accreditation certificate showing the international cooperation. Equivalence at European and world level is underlined in this way.

MultiLateral Agreement (MLA)

The MLA is an efficient means of gaining cross-frontier European and worldwide acceptance for goods and services. The primary MLA for the Council for Accreditation is that with other European accreditation bodies via the EA-MLA. This EA-MLA, in cooperation with the International Laboratory Accreditation Cooperation (ILAC-MLA) and the International Accreditation Forum (IAF-MLA), ensures that accreditation is a 'passport' for simplifying access to the European Union and international markets. The recognisability in the market of the MLA signatories and the bodies declaring conformity accredited by them is simplified by the use of ILAC and IAF logos together with the Council for Accreditation logo (as at end of 2004).

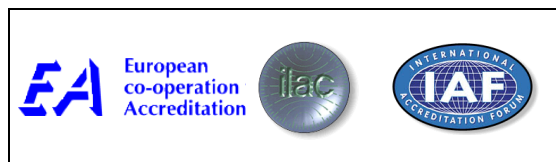

How does the MLA work?

The MLA between accreditation bodies produces mutual confidence in and acceptance of accredited certifications, inspections, calibrations and tests. The MLA removes the need for providers of services and products to be certified in each country for example. Accreditation bodies that are signatories to an MLA are subject to a regular, intensive review by international peers. The purpose of these assessments is to establish that the accreditation body concerned meets and continues to meet the international requirements. These peer reviews guarantee consistent and harmonised accreditation practices and facilitate the sharing of information and experiences between the signatories.

The MLA is an important mechanism in cross-frontier accreditation. It is the policy of the Council for Accreditation to assist users of accredited conformity declarations with worldwide acceptance of these declarations.

SIGNATORIES OF THE MLA FOR TESTING

(ILAC MRA, Bilateral agreements, address)

[Calibration] [Inspection] [Certification (products)] [EMS]

[Certification (quality systems)] [Certification (personnel)]

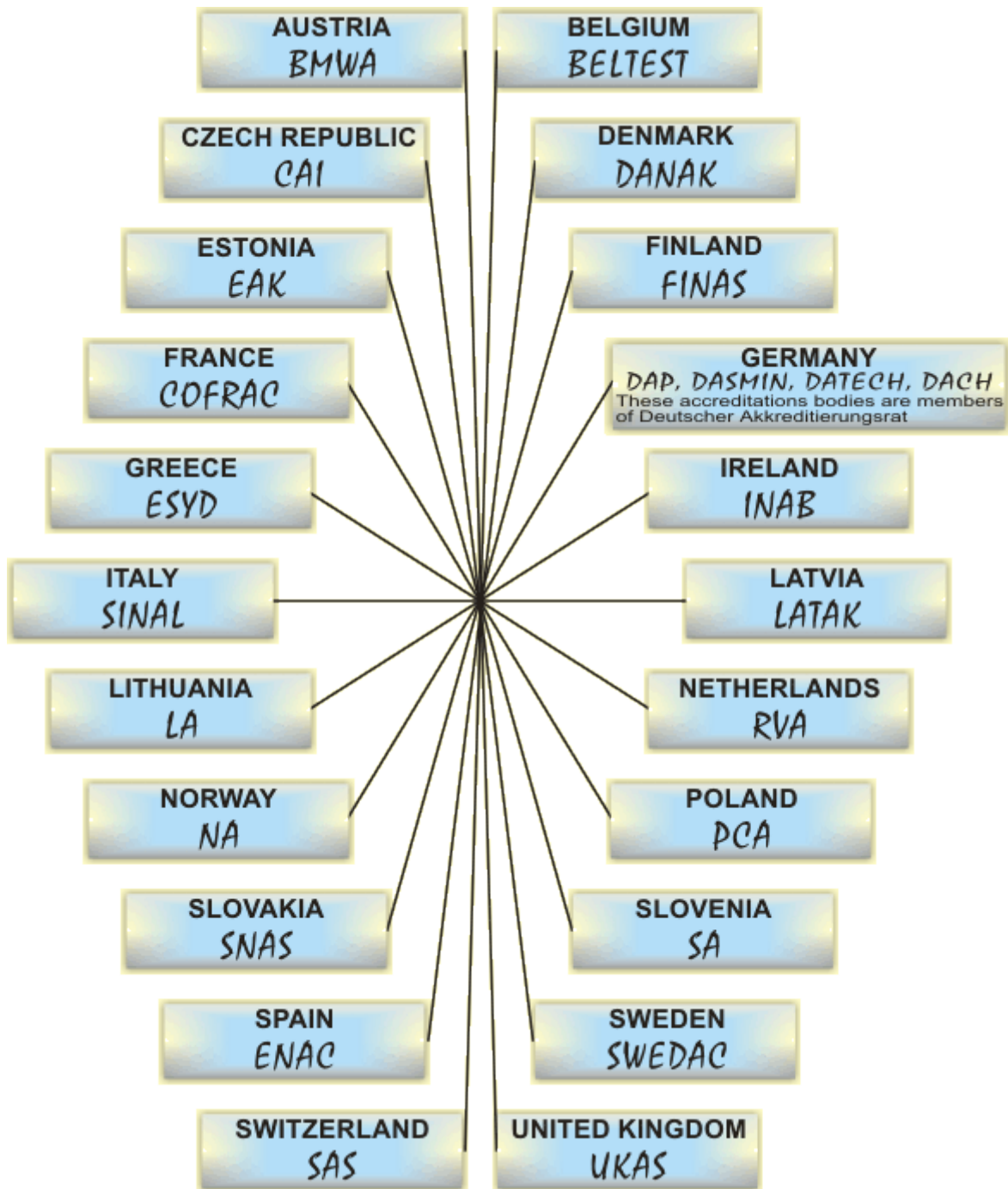

BILATERAL AGREEMENTS

(MLA TESTING, ILAC MRA)

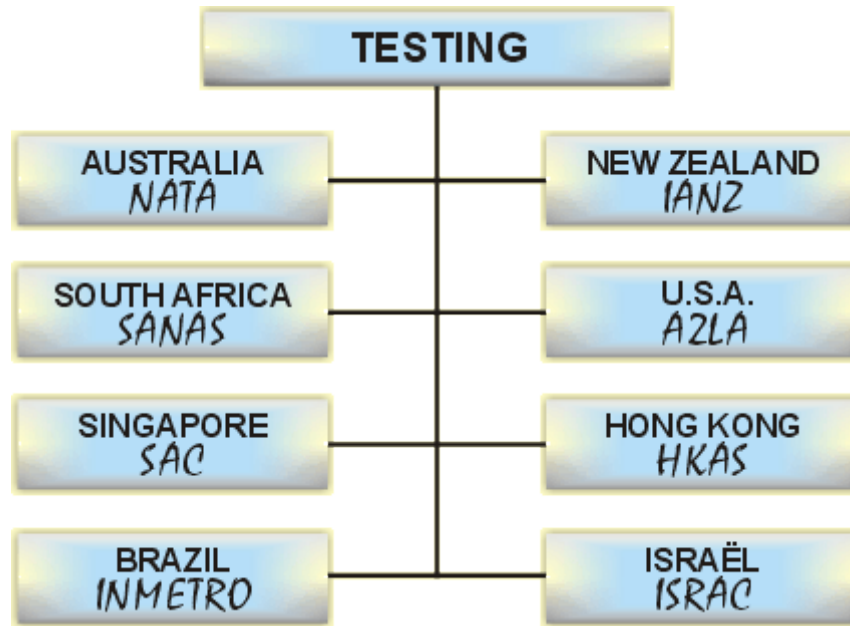

ILAC MRA TESTING

(MLA TESTING, Bilateral agreements)
on recognition and acceptance of tests and calibration results

The list of the signatories is available at:
https://ilac.org/signatory_print.php

1.8 Certification

To attain European acceptance through accreditation work was performed on a structure based on the European standards. This is for product certification, process certification and person certification. Under accreditation FirePro products are subject to the tests described in testing requirements of EN 15276-1 , ISO 15779 and BRL K-23001/05. The following tests and inspections are among those to be found in the testing requirement:

Performance requirements and methods of determination

The stationary autonomous dry aerosol-based extinguishing components must extinguish objects of the respective fire class effectively.

Performance requirement for suspension system for fire extinguishing components

The care for adequate fixing of the extinguishing components in the room where extinguishing must be done.

Product requirements and methods of determination

This chapter contains the product requirements that the extinguishing components must meet and the methods of determination for establishing that the requirements are met.

Thermal ageing

Condensed Aerosol Generators shall have a product life of 15 years

Stability of extinguishing agent

The composition must be determined during the type tests and be registered.

Toxic aspects

The toxic aspects must meet the toxicological requirements and be determined.

Packaging, preservation, storage, identification

The packaging must be tailored to use. If special measures must be taken in connection with preservation, they must be stated in the instructions for use and on the packaging identification label. Storage must be in accordance with the instructions for use in connection with preservation requirements.

Installation and user manual

There shall be a clear user manual available in the language of the country of delivery.

Testing and control

This chapter contains the requirements for testing and control that are carried out for the certification.

Quality level requirements

This chapter contains the requirements that the supplier's quality system must meet.

Installation

The steps to be taken are described in BRL-K23003 and EN 15276-2. The following are among the steps to be found in it:

| | |
|--------------------------------|--|
| Design phase: | Schedule of Requirements (design of extinguishing system, structural provisions, fire detection, ventilation, transmission of fire, fault, etc). |
| 1st inspection phase: | Assessing of Schedule of Requirements by certification or inspection body |
| Testing phase: | By requiring parties (Fire Service, Environment, Insurer, etc). |
| Any adjustments: | Detail engineering (installation drawing, function matrix, block diagram, extinguishing agent required, tool life, etc). |
| 2nd inspection phase: | Control of detail engineering by certification or inspection body. |
| Installation phase: | Installation by CATTAS or FirePro trained personnel on the basis of installation drawing, manual and standards. |
| Delivery: | Delivery of the installation (statement of delivery). |
| Final inspection phase: | As per Authority Having Jurisdiction requirements |



Productcertificate
K21774/20

Issued 2019-11-08
Replaces K21774/19
Page 1 van 13

CERTIFICATE

FirePro Non-Pressurized Condensed Aerosol Generators and Components

STATEMENT BY KIWA

With this product certificate, issued in accordance with the Kiwa Regulations for Certification, Kiwa declares that legitimate confidence exists that the products supplied by

FirePro Systems Ltd.

complying with the technical specifications as laid down in this product certificate and marked with the Kiwa®-mark in the manner as indicated in this product certificate, on delivery, may be relied upon to comply with Kiwa Product Certification Scheme BRL-K23001/05 "for non-pressurized condensed aerosol generators and components used in fixed fire extinguishing systems" of October 1th, 2018.

Kiwa licenses the certification mark to the certified company. The validity of a certificate can be checked on www.kiwafss.nl.

This certificate remains the property of Kiwa. The validity of the accreditation can be verified by the accreditation body (www.rva.nl).

Ronald Karel,
Kiwa

Further information on the application and the applicable certification can be obtained from the certified company.

Publication of the certificate is allowed.

Kiwa Nederland B.V.
Sir Winston Churchilllaan 273
Postbus 70
2289 AB Rijswijk
Tel. 088 998 44 00
www.kiwa.nl
Uitgevoerd door:
Kiwa NCP
info.ncp@kiwa.nl
www.kiwafss.nl

Company
FirePro Systems Ltd
8 Faleas Street
Agios Athanasios Industrial Area
Cy-4101 Limassol - Cyprus
Telephone +357 25379999
Email mail@firepro.com
Internet www.firepro.com

Certification process consists of initial and regular assessment of:

- quality system
- product



Note: This is the first page out of 7. This Certificate may be updated at any time. Please contact FirePro for the latest one.



1.9 Declaration of Conformity

FirePro.

EU Declaration of Conformity

We, FirePro Systems Ltd herewith declare on our sole responsibility that the Fixed Aerosol Fire-Extinguishing Systems/Generators, types FP-20SE, FP-20T, FP-20TH, FP-40S, FP-40T, FP-80S, FP-80T, FP-100S, FP-200S, FP-500S, FP-200M, FP-500M, FP-1000M, FP-1200/S, FP-1200T/TS, FP-2000/S, FP-2000T/TS, FP-3000/S, FP-3000T/TS, FP-4200T/TS, FP-5700/S and FP 5700T/TS (Models with Suffix T/TS do not include MED certification), where to this statement refers complies and fulfils all the relevant provisions of the EMC Directive 2014/30/EU, MED 2014/90/EU, MED Regulation (EU) 2019/1397.

The product has been designed and manufactured by FirePro Systems Ltd in accordance with the standards EN 15276 - Part 1 and Part 2, ISO 15779, UL 2775, NFPA 2010, IMO MSC.1/ Circ.1270/Corr.1, BRL-K23001/05, EN 61000-6-1, EN 61000-6-3, EN 61000-6-3/A1.

The Technical Documentation is maintained at FirePro Systems Ltd.

The Products as detailed above conform to the type described in the EU Type Examination certificates as below:

EMC, Module B Certificate No. 192290001, issued by KIWA EMC, Edisonstraat 12A, 6902 PK Zevenaar Netherlands, Notified Body No. 0560,

MED Module B certificate ref BSI/A.1/3.46/560436, and is manufactured in accordance with production Quality Assurance, MED Module D certificate ref BSI/MED/PC/560437, issued by BSI, Kitemark Court, Davy Avenue, Knowlhill, Milton Keynes, MK5 8PP, U.K., Notified body number 0086.

Signed

Date: 1st November, 2019



Avgoustinos Avgousti
Managing Director

FirePro Systems Ltd
8 Paleas Street, Agios Athanasios Industrial Area, CY-4101 Limassol, Cyprus - EU
Tel.: +357 25 379999, Fax: +357 25 354432, Email: mail@firepro.com
Company registration No. HE137692
www.firepro.com



 Reinventing
Fire Suppression

Note: This Declaration of Conformity may be revised at any time, please contact FirePro for the latest one.

1.10 Test Institutes Worldwide

| Part | Countries | No. | Description |
|--------------|-----------------|-----|--|
| A | Australia | 1. | ActiveFire – Active Fire Protection Equipment Listing Scheme (CSIRO). |
| | (& New Zealand) | 2. | Global Mark |
| | Austria | 1. | STP, Sicherheitstechnische Prüfstelle. |
| B | Belgium | 1. | ANPI - Inspections and Certifications. |
| C | Cyprus | 1. | The Ministry of Justice and Public Orders, Chief Fire officer, Fire Department, Cyprus. |
| | Canada | 1. | ULC – Underwriters Laboratories of Canada. |
| D - E | Denmark | 1. | Danish Maritime Authority. |
| | | 2. | Danish Fire- and Securing Technical Institution (DBI). |
| F – G | Greece | 1. | Ministry of Interior and Public Orders, Commission of Fire Brigades, Greece. |
| | | 2. | The Standards Institution of Greece. |
| H - I | Hungary | 1. | Ministry of Interior, BM TOP Fire Protection Training Institution, Fire Protection Test Laboratory, Budapest, Hungary. |
| | | 2. | Award of Budapest. |
| J – L | Israel | 1. | The Standards Institution of Israel. |
| | | 2. | The Ministry of Environment of Israel & Standards Institution of Israel. |
| | Italy | 1. | Ministry of Interior, General Directorate of Civil Protection and Fire Fighting Services, Italy. |
| | | 2. | Chemical Analysis-University of L'AQUILA, Department of Chemistry, Chemical Engineering and Materials, Italy. |
| | | 3. | RINA, Registry of Italian Navy, Italy. |
| | | 4. | CESI, Italian Electro technical Centre of Experiments, Italy. |
| M - O | Netherlands | 1. | ECB, European Certification Bureau. |
| | | 2. | Ministry of Transport, Public Works and Water Management/Internal Documents Lakeman. |
| | | 3. | KIWA. Certification ISO 17020, ISO 17065, ISO 17025 |
| | | 4. | KEMA. |
| | | 5. | TNO. |
| | | 6. | Ministry of Housing, Spatial Planning and the Environment. |
| | | 7. | Netherlands Shipping Inspectorate. |
| P - Q | Poland | 1. | PCBC, The Product Certification Body, Poland. Scientific and Research Centre for Fire Protection. |
| | | 2. | PZH, Certificate of the National Institute of Hygiene. |
| R - S | Romania | 1. | Ministry of Industrial Affairs, General Inspectorate of the Military Fire Squad, Romania. |
| | South Africa | 1. | South African Bureau of Standards, South Africa |
| | | 2. | CITY COUNCIL OF PRETORIA, South Africa Community Safety Department, Fire Brigade & Ambulance Services. |
| | Sweden | 1. | Approval Swedish Ministry (ships). |
| T - Z | U.K. | 1. | BSI |
| | | 2. | BRE-LPCB |
| | USA | 2. | BSI Product Services. |
| | | 3. | UL-Underwriters Laboratories |

2 Purpose and Use

Target group

Only suitably trained and certified persons who are members of the authorised FirePro sales organisation are allowed to use this user manual.

Scope

The autonomous stationary dry aerosol-based fire extinguishing components are designed for use as part of a fire extinguishing system. It is a precondition that the extinguishing components are linked to and activated by an effective fire detection system. Rapid detection and a fast reaction are essential in this regard.

It is a fire extinguishing component consisting of a packaging filled with a dry solid extinguishing agent which, following activation, is discharged as a dry aerosol with the function of extinguishing the fire.

FirePro aerosol fire extinguishers and fire extinguishing systems are designed for the suppression of class A, B, C and F fires (as per EN2 Standard classification of fires)

FirePro aerosol fire extinguishers and fire extinguishing systems provide an efficient and effective way of extinguishing gas and liquid fires and burning solids, especially if the substances are derived from hydrocarbons (natural gas, oil products, flammable lubricants, etc), but also boiling oils and burning fats and fires in electrical equipment with an operating voltage not exceeding 75,000 volts.

FirePro aerosol fire extinguishers and fire extinguishing systems must not be used in cases of:

- Core fires as referred to in class A
(Development of fire within a product or a quantity of products through the fuel, oxygen and temperature present therein without drawing them in from the surrounding area).
- Oxygen-bearing chemical substances such as nitro-cellulose and gunpowder.
- Reactive metals such as lithium, sodium, potassium, magnesium, titanium, zirconium, uranium and plutonium.
- Metal oxides.
- Organic peroxides and hydrazine.

Dry aerosol extinguishing products may not be used in rooms with fuels or dust that can cause an explosive vapour/air mixture and for which a zone layout in accordance with the provisions of NPR 7910-1, NPR 7910-2, EN 60079-10-1 and EN 60079-10-2 has been laid down, unless appropriate arrangements have been made in the protected room so that the European ATEX Directive is met.

3 Safety Measures



Before bringing the FirePro units into use please read through this user manual carefully.



When working with aerosol fire extinguishers and fire extinguishing systems it is prohibited to:

Dismantle the units;

Subject the units to the force of impact or other operations that can result in the deformation, physical or other mechanical damage of the container;

Carry out welding work in the proximity of the fire extinguishers and/or fire extinguishing systems
Smoke in the vicinity of the fire extinguishers and/or fire extinguishing systems.



Should a FirePro unit have fallen, it must be checked to determine whether or not the electrical circuit of the activator and/or other components have been damaged. If you cannot be certain that the FirePro unit is undamaged and/or will function properly, it must not be used and it must be returned to the distributor.



The Working Conditions Act and health & safety information sheets

Ensure that you adhere to the obligations and advice described in the Working Conditions Act and health & safety information sheets. Pay particular attention to working at height. Ensure that you stand firmly and use reliable tools, materials and the correct personal protective equipment. Please address any questions to your employer and/or health & safety department.

4 Storage and Transport

FirePro units are transported in accordance with the regulations and requirements applying to this category of cargo. Transport by air, land and water is permitted using any means of transport without any restrictions. FirePro units that are transported must be securely fastened and protected from dirt, moisture and precipitation.



Important: Do not drop FirePro units during loading or unloading.
Put the correct labels on the packaging in a prominent place.



Storage of FirePro units takes place in their own packaging on racks in stores (either heated or unheated with natural ventilation, at a distance of not less than one metre from heaters).

Storage conditions:

Temperature: between -50 and $+100$ °C

Humidity: maximum 98% RH

5 Design, Generators Models and Data Sheets

5.1 Design

General description of FirePro units:

- 1) The fire extinguishers are metal containers of different shapes and sizes.
- 2) The solid, aerosol-forming compound FPC is used (see chemical analysis).
- 3) A special system is built into each container for the independent activation of the fire extinguisher.
- 4) Most models are equipped with a heat-absorbing mechanism (depending on the application).

FirePro units can be supplied with two-sided discharge (exit openings). In this case the aerosol-forming substance is placed together with the activation system in the central part of the container between two heat-absorbing mechanisms and two membranes on the opening where the aerosol exits.

By applying a given amperage to the live parts of the aerosol fire extinguisher, or when a thermal actuation means provides the necessary heat, the extinguishing agent is activated and converted into aerosol. If the aerosol exits via the heat-absorbing elements (if applicable), it is cooled before flooding the protected volume, the fire being extinguished at the same time by retarding the combustion chain reaction.

FirePro unit designations:

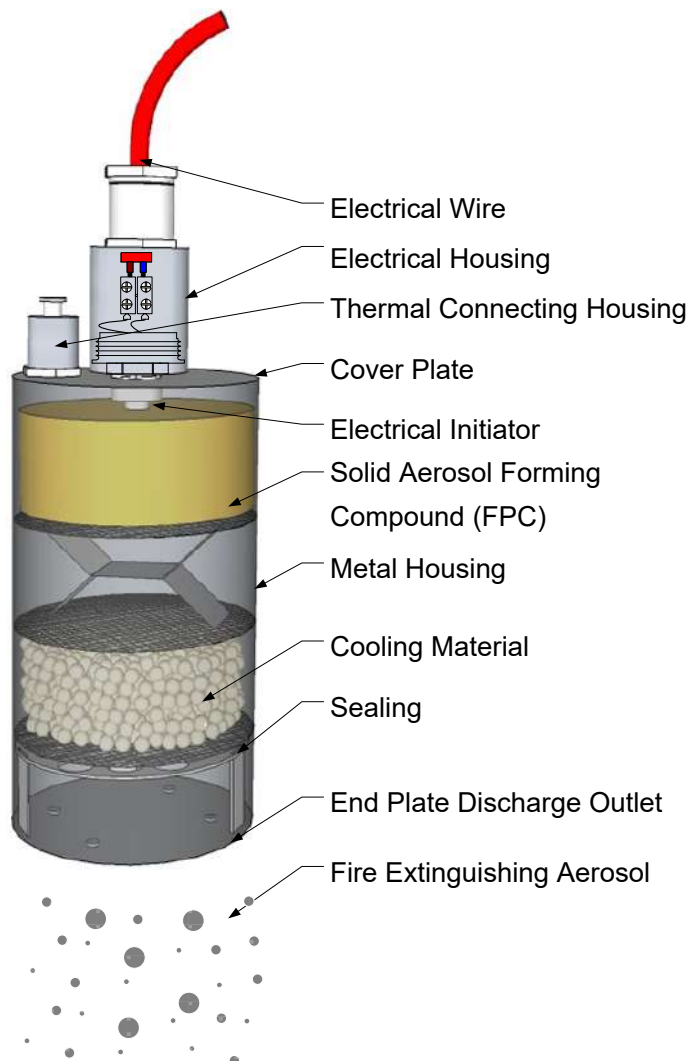

5.2 Overview of Various Generator Models



FP-20SE / FP-20T / FP-20TH



FP-40S / FP-40T



FP-80S / FP-80T



FP-100S



FP-200S



FP-500S



FP-1200S /
FP1200TS



FP-2000S /
FP-2000TS



FP-3000S /
FP-3000TS



FP-4200TS



FP-5700S /
FP-5700TS

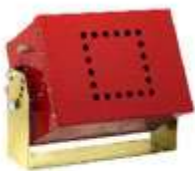

FP-1200 /
FP-1200T



FP-2000 /
FP-2000T



FP-3000 /
FP-3000T





FP-4200T



FP-5700 /
FP-5700T

5.3 Data Sheets

| | | |
|---|---|---|
| <p>FP-20SE</p>  | TECHNICAL INFORMATION | |
| | Model | FP-20SE |
| | Activation mechanism | electrical (min.1.5V DC, min 0.8A in 3-4 sec) |
| | Activ. line supervision current | maximum 5 mA |
| | Weight gross | 310 g |
| | Mass of FPC Compound | 20 g |
| | Operational discharge time | 5 - 10 seconds |
| | Discharge outlet | 2 |
| | Discharge length | 1.0 m |
| | Size | 165 mm x 32 mm (incl. connector housing) |
| | Self activation temperature | 300 °C |
| | Fire class | A, B, C, F |
| | APPLICATIONS | |
| | Cabinets Instrumentation Switch boxes (medium) Transformers (medium) | electrical cabinets mechanical machines relay boxes, meter cupboards (small) portable welders Certified according to EN 15276-1, BRL 23001 and ISO 15779 |

| | | |
|--|---|---|
| <p>FP-20T</p>  | TECHNICAL INFORMATION | |
| | Model | FP-20T |
| | Activation mechanism | electrical (min.1.5V DC,min 0.8A in 3-4 sec) |
| | Activ. line supervision current | maximum 5 mA |
| | Weight gross | 310 g |
| | Mass of FPC Compound | 20 g |
| | Operational discharge time | 5 - 10 seconds |
| | Discharge outlet | 1 |
| | Discharge length | 1.0 m |
| | Size | 165 mm x 32 mm (incl. connector housing) |
| | Self activation temperature | 300 °C |
| | Fire class | A, B, C, F |
| | APPLICATIONS | |
| | Cabinets Instrumentation Switch boxes (medium) Transformers (medium) | electrical cabinets mechanical machines relay boxes, meter cupboards (small) portable welders Certified according to EN 15276-1, BRL 23001 and ISO 15779 |

FP-20TH



| TECHNICAL INFORMATION | |
|---|---|
| Model | FP-20TH |
| Activation mechanism | thermal |
| Activ. line supervision current | N/A |
| Weight gross | 310 g |
| Mass of FPC Compound | 20 g |
| Operational discharge time | 5 - 10 seconds |
| Discharge outlet | 1 |
| Discharge length | 1.0 m |
| Size | 165 mm x 32 mm (incl. connector housing) |
| Self activation temperature | 300 °C |
| Fire class | A, B, C, F |
| APPLICATIONS | |
| Cabinets Instrumentation Switch boxes (medium) Transformers (medium) | electrical cabinets mechanical machines relay boxes, meter cupboards (small) portable welders Certified according to EN 15276-1, BRL 23001 and ISO 15779 |

| <p style="text-align: center;">FP-40S</p>  | TECHNICAL INFORMATION | |
|--|---|---|
| | Model | FP-40S |
| | Activation mechanism | electrical (min.1.5V DC,min 0.6A in 3-4 sec) |
| | Activator type | heating element with 2.3 ohm resistance |
| | Activ. line supervision current | maximum 5 mA |
| | Weight gross | 610 g |
| | Mass of FPC Compound | 40 g |
| | Operational discharge time | 5 - 10 seconds |
| | Discharge outlets | 2 |
| | Discharge length | 1.0 m |
| | Size | 140 mm x 51 mm |
| | Self activation temperature | 300 °C |
| | Fire class | A, B, C, F |
| | APPLICATIONS | |
| | Cabinets Instrumentation Switch boxes (medium) Transformers (medium) | electrical cabinets mechanical machines relay boxes, meter cupboards (small) portable welders Certified according to EN 15276-1, BRL 23001 and ISO 15779 |

| <p style="text-align: center;">FP-40T</p>  | TECHNICAL INFORMATION | |
|--|---|---|
| | Model | FP-40T |
| | Activation mechanism | thermal activation electrical (min.1.5V DC,min 0.6A in 3-4 sec) |
| | Activator type | heating element with 2.3 ohm resistance |
| | Activ. line supervision current | maximum 5 mA |
| | Weight gross | 610 g |
| | Mass of FPC Compound | 40 g |
| | Operational discharge time | 5 - 10 seconds |
| | Discharge outlets | 1 |
| | Discharge length | 1.0 m |
| | Size | 140 mm x 51 mm |
| | Self activation temperature | 300 °C |
| | Fire class | A, B, C, F |
| | APPLICATIONS | |
| | Cabinets Instrumentation Switch boxes (medium) Transformers (medium) | electrical cabinets mechanical machines relay boxes, meter cupboards (small) portable welders Certified according to EN 15276-1, BRL 23001 and ISO 15779 |

FP-80S



TECHNICAL INFORMATION

| | |
|---------------------------------|--|
| Model | FP-80S |
| Activation mechanism | electrical (min.1.5V DC,min 0.8A in 3-4 sec) |
| Activator type | heating element with 2.3 ohm resistance |
| Activ. line supervision current | maximum 5 mA |
| Weight gross | 870 g |
| Mass of FPC Compound | 80 g |
| Operational discharge time | 5 - 10 seconds |
| Discharge outlets | 2 |
| Discharge length | 2 m |
| Size | 185 mm x 51 mm (incl. connector housing) |
| Self activation temperature | 300 °C |
| Fire class | A, B, C, F |

APPLICATIONS

| | |
|---|--|
| Cabinets Instrumentation Switch boxes (medium) Transformers (medium) | electrical cabinets mechanical machines relay boxes, meter cupboards (small) portable welders |
| | Certified according to EN 15276-1, BRL 23001 and ISO 15779 |

FP-80T





TECHNICAL INFORMATION

| | |
|---------------------------------|--|
| Model | FP-80T |
| Activation mechanism | thermal activation electrical (min.1.5V DC,min 0.8A in 3-4 sec) |
| Activator type | heating element with 2.3 ohm resistance |
| Activ. line supervision current | maximum 5 mA |
| Weight gross | 870 g |
| Mass of FPC Compound | 80 g |
| Operational discharge time | 5 - 10 seconds |
| Discharge outlets | 1 |
| Discharge length | 2 m |
| Size | 185 mm x 51 mm (incl. connector housing) |
| Self activation temperature | 300 °C |
| Fire class | A, B, C, F |

APPLICATIONS

| | |
|---|--|
| Cabinets Instrumentation Switch boxes (medium) Transformers (medium) | electrical cabinets mechanical machines relay boxes, meter cupboards (small) portable welders |
| | Certified according to EN 15276-1, BRL 23001 and ISO 15779 |

| <p style="text-align: center;">FP-100S</p>  | TECHNICAL INFORMATION | |
|---|--|---|
| | Model | FP-100S |
| | Activation mechanism | thermal activation electrical (min.1.5V DC,min 0.8A in 3-4 sec) |
| | Activator type | Heating element with 2.3 ohm resistance |
| | Activ. line supervision current | Maximum 5 mA |
| | Weight gross | 1370 g |
| | Mass of FPC Compound | 100 g |
| | Operational discharge time | 5 - 10 seconds |
| | Discharge outlet | 1 |
| | Discharge length | 1 m |
| | Size | 155 mm x 84 mm (incl. connector housing) |
| | Self activation temperature | 300 °C |
| | Fire class | A, B, C, F |
| | APPLICATIONS | |
| | Transport Instrumentation Large switch boxes Cabinets Transformers (large) | car, lorry, bus, train, metro, tram cupboards, safes meter cupboards, control units electrical cabinets industry Certified according to EN 15276-1, BRL 23001 and ISO 15779 |

| <p style="text-align: center;">FP-200S</p>  | TECHNICAL INFORMATION | |
|---|---|---|
| | Model | FP-200S |
| | Activation mechanism | thermal activation electrical (min.1.5V DC,min 0.8A in 3-4 sec) |
| | Activator type | heating element with 2.3 ohm resistance |
| | Activ. line supervision current | maximum 5 mA |
| | Weight gross | 1840 g |
| | Mass of FPC Compound | 200 g |
| | Operational discharge time | 5 - 10 seconds |
| | Discharge outlet | 1 |
| | Discharge length | 2 m |
| | Size | 185 mm x 84 mm (incl. connector housing) |
| | Self activation temperature | 300 °C |
| | Fire class | A, B, C, F |
| | APPLICATIONS | |
| | Rooms Transport Storage Large switch rooms Cabinets Transformers (large) | server rooms, ceilings, floors car, lorry, bus, train, metro, tram cupboards, safes meter cupboards, control units electrical cabinets industry Certified according to EN 15276-1, BRL 23001 and ISO 15779 |

FP-500S





TECHNICAL INFORMATION



| | |
|---------------------------------|--|
| Model | FP-500S |
| Activation mechanism | thermal activation electrical (min.1.5V DC,min 0.8A in 3-4 sec) |
| Activator type | heating element with 2.3 ohm resistance |
| Activ. line supervision current | maximum 5 mA |
| Weight gross | 3340 g |
| Mass of FPC Compound | 500 g |
| Operational discharge time | 5 - 10 seconds |
| Discharge outlet | 1 |
| Discharge length | 3.0 m |
| Size | 295 mm x 84 mm (incl. connector housing) |
| Self activation temperature | 300 °C |
| Fire class | A, B, C, F |

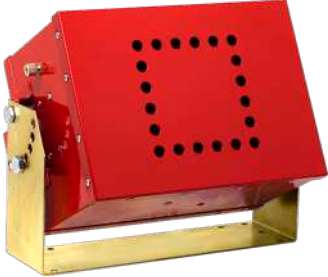
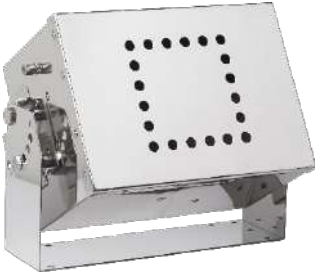

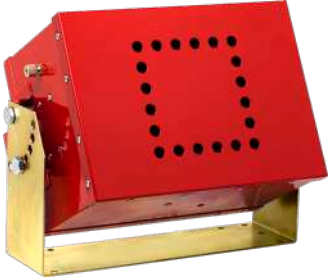
APPLICATIONS



| | |
|----------------------|---|
| Rooms | False ceilings, Raised floors |
| Transport | car, lorry, bus, train, metro, tram |
| Storage | cupboards, safes |
| Large switch rooms | meter cupboards, control units |
| Cabinets | electrical cabinets |
| Transformers (large) | industry |
| | Certified according to EN 15276-1, BRL 23001 and ISO 15779 |



| | | |
|--|---|--|
| <p>FP-1200/FP-1200S</p>   | TECHNICAL INFORMATION | |
| | Model | FP-1200/FP-1200S |
| | Activation mechanism | electrical (min.1.5V DC,min 0.8A in 3-4 sec) |
| | Activator type | heating element 2.3 ohm resistance |
| | Activ. line supervision current | maximum 5 mA |
| | Weight gross | 10900 g (excl bracket) |
| | Mass of FPC Compound | 1200 g |
| | Operational discharge time | 10 -15 seconds |
| | Discharge outlet | 1 |
| | Discharge length | 3.5 m |
| | Size | 216 mm x 300 mm x 167 mm |
| | Fire class | A, B, C, F |
| | APPLICATIONS | |
| | Rooms Transport Storage Mechanical rooms Industry | <p>central control rooms, various shipping, train, aircraft store, archive engine rooms, plant rooms various</p> <p>Certified according to EN 15276-1, BRL 23001 and ISO 15779</p> |

| | | |
|--|---|--|
| <p>FP-1200T/FP-1200TS</p>   | TECHNICAL INFORMATION | |
| | Model | FP-1200T/FP-1200TS |
| | Activation mechanism | thermal activation electrical (min.1.5V DC,min 0.8A in 3-4 sec) |
| | Activator type | heating element 2.3 ohm resistance |
| | Activ. line supervision current | maximum 5 mA |
| | Weight gross | 10900 g (excl bracket) |
| | Mass of FPC Compound | 1200 g |
| | Operational discharge time | 10 -15 seconds |
| | Discharge outlet | 1 |
| | Discharge length | 3.5 m |
| | Size | 216 mm x 300 mm x 167 mm |
| | Fire class | A, B, C, F |
| | APPLICATIONS | |
| | Rooms Transport Storage Mechanical rooms Industry | <p>central control rooms, various shipping, train, aircraft store, archive engine rooms, plant rooms various</p> <p>Certified according to EN 15276-1, BRL 23001 and ISO 15779</p> |

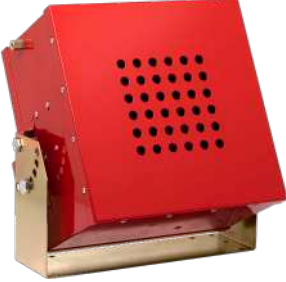
| | | |
|--|--|------------------|
| <p>FP-2000/FP-2000S</p>   | TECHNICAL INFORMATION | |
| | Model | FP-2000/FP-2000S |
| Activation mechanism | electrical (min.1.5V DC,min 0.8A in 3-4 sec) | |
| Activator type | heating element 2.3 ohm resistance | |
| Activ. line supervision current | maximum 5 mA | |
| Weight gross | 15500 g | |
| Mass of FPC Compound | 2000 g | |
| Operational discharge time | 10 - 15 seconds | |
| Discharge outlet | 1 | |
| Discharge length | 3.5 m | |
| Size | 300 mm x 300 mm x 185 mm | |
| Self activation temperature | 300 °C | |
| Fire class | A, B, C, F | |
| APPLICATIONS | | |
| Rooms Transport Storage Mechanical rooms Industry | <p>central control rooms, various shipping, train, aircraft store, archive engine rooms, plant rooms various</p> <p>Certified according to EN 15276-1, BRL 23001 and ISO 15779</p> | |

| | | |
|--|--|--------------------|
| <p>FP-2000T/FP-2000TS</p>   | TECHNICAL INFORMATION | |
| | Model | FP-2000T/FP-2000TS |
| Activation mechanism | thermal activation electrical (min.1.5V DC,min 0.8A in 3-4 sec) | |
| Activator type | heating element 2.3 ohm resistance | |
| Activ. line supervision current | maximum 5 mA | |
| Weight gross | 15500 g | |
| Mass of FPC Compound | 2000 g | |
| Operational discharge time | 10 - 15 seconds | |
| Discharge outlet | 1 | |
| Discharge length | 3.5 m | |
| Size | 300 mm x 300 mm x 185 mm | |
| Self activation temperature | 300 °C | |
| Fire class | A, B, C, F | |
| APPLICATIONS | | |
| Rooms Transport Storage Mechanical rooms Industry | <p>central control rooms, various shipping, train, aircraft store, archive engine rooms, plant rooms various</p> <p>Certified according to EN 15276-1, BRL 23001 and ISO 15779</p> | |

| | | |
|---|---|--|
| <p>FP-3000/FP-3000S</p>   | TECHNICAL INFORMATION | |
| | Model | FP-3000/FP-3000S |
| | Activation mechanism | electrical (min.1.5V DC,min 0.8A in 3-4 sec) |
| | Activator type | heating element 2.3 ohm resistance |
| | Activ. line supervision current | maximum 5 mA |
| | Weight gross | 16300 g |
| | Mass of FPC Compound | 3000 g |
| | Operational discharge time | 15 - 20 seconds |
| | Discharge outlet | 1 |
| | Discharge length | 4 m |
| | Size | 300 mm x 300 mm x 185 mm |
| | Self activation temperature | 300 °C |
| | Fire class | A, B, C, F |
| | APPLICATIONS | |
| Rooms Transport Storage Mechanical rooms Industry | control rooms, various shipping, train, aircraft store, archive engine rooms, plant rooms various | |

| | | |
|--|--|--|
| <p>FP-3000T/FP-3000TS</p>   | TECHNICAL INFORMATION | |
| | Model | FP-3000T/FP-3000TS |
| | Activation mechanism | thermal activation electrical (min.1.5V DC,min 0.8A in 3-4 sec) |
| | Activator type | heating element 2.3 ohm resistance |
| | Activ. line supervision current | maximum 5 mA |
| | Weight gross | 16300 g |
| | Mass of FPC Compound | 3000 g |
| | Operational discharge time | 15 - 20 seconds |
| | Discharge outlet | 1 |
| | Discharge length | 4 m |
| | Size | 300 mm x 300 mm x 185 mm |
| | Self activation temperature | 300 °C |
| | Fire class | A, B, C, F |
| | APPLICATIONS | |
| Rooms Transport Storage Mechanical rooms Industry | central control rooms, various shipping, train, aircraft store, archive engine rooms, plant rooms various Certified according to EN 15276-1, BRL 23001 and ISO 15779 | |

FP-4200T/FP-4200TS

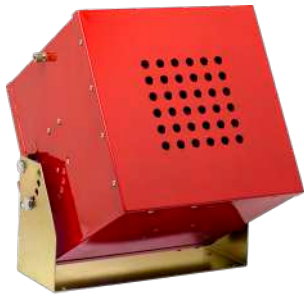

TECHNICAL INFORMATION

| | |
|---------------------------------|---|
| Model | FP-4200T/FP-4200TS |
| Activation mechanism | thermal activation port electrical (min.1.5V DC,min 0.8A in 3-4 sec) |
| Activator type | heating element 2.3 ohm resistance |
| Activ. line supervision current | maximum 5 mA |
| Weight gross | 23600 g |
| Mass of FPC Compound | 4200 g |
| Operational discharge time | 15 - 20 seconds |
| Discharge outlet | 1 |
| Discharge length | 5 m |
| Size | 300 mm x 300 mm x 300 mm |
| Self activation temperature | 300 °C |
| Fire class | A, B, C, F |

APPLICATIONS

| | |
|------------------|---|
| Rooms | central control rooms, various |
| Transport | shipping, train, aircraft |
| Storage | store, archive |
| Mechanical rooms | engine rooms, plant rooms |
| Industry | various |
| | Certified according to EN 15276-1, BRL 23001 and ISO 15779 |

FP-5700/FP-5700S

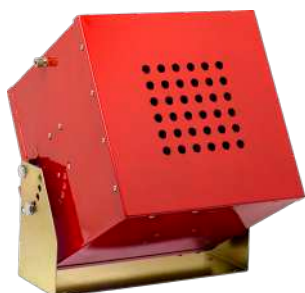

TECHNICAL INFORMATION

| | |
|---------------------------------|--|
| Model | FP-5700/FP-5700S |
| Activation mechanism | electrical (min.1.5V DC,min 0.8A in 3-4 sec) |
| Activator type | heating element 2.3 ohm resistance |
| Activ. line supervision current | maximum 5 mA |
| Weight gross | 26400 g |
| Mass of FPC Compound | 5700 g |
| Operational discharge time | 15 - 20 seconds |
| Discharge outlet | 1 |
| Discharge length | 8 m |
| Size | 300 mm x 300 mm x 300 mm |
| Self activation temperature | 300 °C |
| Fire class | A, B, C, F |

APPLICATIONS

| | |
|--|--------------------------------|
| Rooms | central control rooms, various |
| Transport | shipping, train, aircraft |
| Storage | store, archive |
| Mechanical rooms | engine rooms, plant rooms |
| Industry | various |
| Certified according to EN 15276-1, BRL 23001 and ISO 15779 | |

FP-5700T/FP-5700TS



TECHNICAL INFORMATION

| | |
|---------------------------------|--|
| Model | FP-5700T/FP-5700TS |
| Activation mechanism | thermal activation port electrical (min.1.5V DC, min 0.8A in 3-4 sec) |
| Activator type | heating element 2.3 ohm resistance |
| Activ. line supervision current | maximum 5 mA |
| Weight gross | 26400 g |
| Mass of FPC Compound | 5700 g |
| Operational discharge time | 15 - 20 seconds |
| Discharge outlet | 1 |
| Discharge length | 8 m |
| Size | 300 mm x 300 mm x 300 mm |
| Self activation temperature | 300 °C |
| Fire class | A, B, C, F |

APPLICATIONS

| | |
|--|--------------------------------|
| Rooms | central control rooms, various |
| Transport | shipping, train, aircraft |
| Storage | store, archive |
| Mechanical rooms | engine rooms, plant rooms |
| Industry | various |
| Certified according to EN 15276-1, BRL 23001 and ISO 15779 | |

6 Risk Assessment

Risk assessment is a series of logical steps for enabling, in a systematic manner, the appraisal of hazards associated with installations. Risk assessment is followed, if the need arises, by risk reduction as described in chapter 5 of EN-ISO 12100. Repetition of this procedure sets in train the iterative process by which risks are excluded as far as possible and safety measures are taken.

Risk assessment comprises (see figure 1):

- Risk analysis.
 - a) Determination of the limits of the installation.
 - b) Identification of (latent) hazards.
 - c) Risk estimation.
- Risk evaluation.

The risk analysis provides the information needed for the risk evaluation, which in its turn allows a judgment to be made about the safety of the installation (see EN-ISO 12100).

Risk assessment depends on judicious decisions. These decisions must be supported by qualitative methods and, where possible, be supplemented by quantitative methods. Quantitative methods are especially applicable if the foreseeable scope of the damage is high.

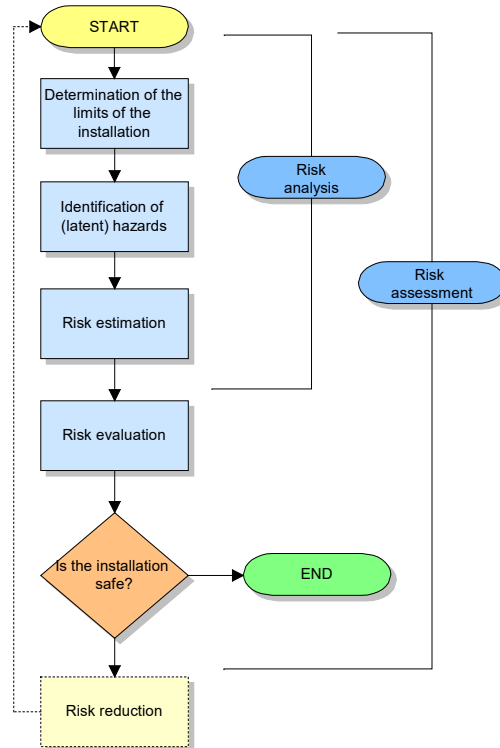

Quantitative methods are useful for assessing and for determining alternative safety measures that give measures better protection.



The application of quantitative methods is limited by the amount of usable information available and in many applications only a qualitative risk assessment will be possible.

The risk assessment must be carried out so that it is possible to document the procedure followed and the results achieved.

Risk reduction and the choice of suitable safety measures do not form part of the risk assessment. You are advised to read EN-ISO 12100.



An overview of risk assessment can be found EN-ISO 12100

7 Calculation of Amount of FirePro Required

$$\text{Formula: } M = \frac{V \times F \text{ (g)}}{f} \times S$$

Where:

M = Solid Mass of FirePro Compound (FPC)

V = Volume (m³. L x W x H) of the room to be protected.

F = Effective extinguishing application density of FPC in relation to the fire class.
(A & E = 46 gr/ m³, B = 52 gr/ m³, C = 30 gr/ m³, F = 76 gr/m³)

S = Safety factor (1.3) in accordance with EN 15276-1:2019 and EN 15276-2:2019

f = Efficiency coefficient of generator's model (%) (net mass of agent delivered by a generator model (size))

| Efficiency coefficients (related to each generator model (size)): | |
|---|-----------------------------|
| FP20SE = 60% = 12 gr | FP1200/S = 63% = 756 gr |
| FP20T = 70% = 14 gr | FP1200T/TS = 63% = 756 gr |
| FP20TH = 70% = 14 gr | FP2000/S = 60% = 1,200 gr |
| FP40S = 61% = 24.4 gr | FP2000T/TS = 60% = 1,200 gr |
| FP40T = 62% = 24.8 gr | FP3000/S = 61% = 1,830 gr |
| FP80S = 59% = 47.2 gr | FP3000T/TS = 61% = 1,830 gr |
| FP80T = 60% = 48 gr | FP4200T/TS = 60% = 2,520 gr |
| FP100S = 61% = 61 gr | FP5700/S = 59% = 3,363 gr |
| FP200S = 59% = 118 gr | FP5700T/TS = 59% = 3,363 gr |
| FP500S = 66% = 330 gr | |

The total number of generators (N) to be used is derived by the following formula:

$$N = \frac{M \text{ (total agent mass)}}{\text{Nominal mass (initial mass of the solid compound) of each generator model (size)}}$$

Example: FP2000 = 2000 grams of nominal mass

FP5700 = 5700 grams of nominal mass

Note: If different generator models (size) should be selected, the total mass of extinguishant (FPC compound) shall not be less than the quantity required (**M**).

Calculation Method based on EN 15276-1:2019 and EN 15276-2:2019

Calculation method

Date of calculation

Certified supplier
 Address
 ZIP code
 Place
 Country
 Contact person
 Telephone number
 E-mail address

Name of client
 Address
 ZIP code
 Place
 Country
 Contact person
 Telephone number
 E-mail address

Calculation effective amount per m² in grams

Building name/no.

Safety factor 1.3

| | | | | | | | | | | | | | | |
|----------------------------------|--------|--|-------|--|--------|--|----------------|--|--|--|--|--|--|--|
| Room name/no. | | | | | | | | | | | | | | |
| To protect m ² | Length | | Width | | Height | | m ² | | | | | | | |
| Fire Class / m ² | A & E | | B | | C | | F | | | | | | | |
| Total effect. per m ² | 46.00 | | 52.00 | | 30.00 | | 76.00 | | | | | | | |
| | 0.00 | | 0.00 | | 0.00 | | 0.00 | | | | | | | |

| | | | | | | | | | | | | | | | | | | | | | | | |
|-------------------------------|---------|-----------|--------|--------|--------|--------|---------|---------|---------|--------------------------|--------------------------|--------------------------|-------------|--------------------------|------|---|------|---|------|---|------|--|------|
| Amount of grams | | | | | | | | | | | | | | A & E | 0.00 | B | 0.00 | C | 0.00 | F | 0.00 | | 0.00 |
| Type unit | FP-20SE | FP-20T/TH | FP-40S | FP-40T | FP-80S | FP-80T | FP-100S | FP-200S | FP-500S | FP-1200/S FP-1200T/TS | FP-2000/S FP-2000T/TS | FP-3000/S FP-3000T/TS | FP-4200T/TS | FP-5700/S FP-5700T/TS | | | | | | | | | |
| Effective ext. agent per unit | 12.00 | 14.00 | 24.40 | 24.80 | 47.20 | 48.00 | 61.00 | 118.00 | 330.00 | 756.00 | 1200.00 | 1830.00 | 2520.00 | 3363.00 | | | | | | | | | |
| Number of units, Class A&E | 0.00 | 0.00 | 0.00 | 0.00 | 0.00 | 0.00 | 0.00 | 0.00 | 0.00 | 0.00 | 0.00 | 0.00 | 0.00 | 0.00 | | | | | | | | | |
| Number of units, Class B | 0.00 | 0.00 | 0.00 | 0.00 | 0.00 | 0.00 | 0.00 | 0.00 | 0.00 | 0.00 | 0.00 | 0.00 | 0.00 | 0.00 | | | | | | | | | |
| Number of units, Class C | 0.00 | 0.00 | 0.00 | 0.00 | 0.00 | 0.00 | 0.00 | 0.00 | 0.00 | 0.00 | 0.00 | 0.00 | 0.00 | 0.00 | | | | | | | | | |
| Number of units, Class F | 0.00 | 0.00 | 0.00 | 0.00 | 0.00 | 0.00 | 0.00 | 0.00 | 0.00 | 0.00 | 0.00 | 0.00 | 0.00 | 0.00 | | | | | | | | | |
| Number of units Design | | | | | | | | | | | | | | | | | | | | | | | |

| | | | | | | | | | | | | | | |
|----------------------------------|--------|--|-------|--|--------|--|----------------|--|--|--|--|--|--|--|
| Room name/no. | | | | | | | | | | | | | | |
| To protect m ² | Length | | Width | | Height | | m ² | | | | | | | |
| Fire Class / m ² | A & E | | B | | C | | F | | | | | | | |
| Total effect. per m ² | 46.00 | | 52.00 | | 30.00 | | 76.00 | | | | | | | |
| | 71.76 | | 67.60 | | 39.00 | | 99.80 | | | | | | | |

| | | | | | | | | | | | | | | | | | | | | | | | |
|-------------------------------|---------|-----------|--------|--------|--------|--------|---------|---------|---------|--------------------------|--------------------------|--------------------------|-------------|--------------------------|------|---|------|---|------|---|------|--|------|
| Amount of grams | | | | | | | | | | | | | | A & E | 0.00 | B | 0.00 | C | 0.00 | F | 0.00 | | 0.00 |
| Type unit | FP-20SE | FP-20T/TH | FP-40S | FP-40T | FP-80S | FP-80T | FP-100S | FP-200S | FP-500S | FP-1200/S FP-1200T/TS | FP-2000/S FP-2000T/TS | FP-3000/S FP-3000T/TS | FP-4200T/TS | FP-5700/S FP-5700T/TS | | | | | | | | | |
| Effective ext. agent per unit | 12.00 | 14.00 | 24.40 | 24.80 | 47.20 | 48.00 | 61.00 | 118.00 | 330.00 | 756.00 | 1200.00 | 1830.00 | 2520.00 | 3363.00 | | | | | | | | | |
| Number of units, Class A&E | 0.00 | 0.00 | 0.00 | 0.00 | 0.00 | 0.00 | 0.00 | 0.00 | 0.00 | 0.00 | 0.00 | 0.00 | 0.00 | 0.00 | | | | | | | | | |
| Number of units, Class B | 0.00 | 0.00 | 0.00 | 0.00 | 0.00 | 0.00 | 0.00 | 0.00 | 0.00 | 0.00 | 0.00 | 0.00 | 0.00 | 0.00 | | | | | | | | | |
| Number of units, Class C | 0.00 | 0.00 | 0.00 | 0.00 | 0.00 | 0.00 | 0.00 | 0.00 | 0.00 | 0.00 | 0.00 | 0.00 | 0.00 | 0.00 | | | | | | | | | |
| Number of units, Class F | 0.00 | 0.00 | 0.00 | 0.00 | 0.00 | 0.00 | 0.00 | 0.00 | 0.00 | 0.00 | 0.00 | 0.00 | 0.00 | 0.00 | | | | | | | | | |
| Number of units Design | | | | | | | | | | | | | | | | | | | | | | | |

| | | | | | | | | | | | | | | |
|-----------------------|---------|-----------|--------|--------|--------|--------|---------|---------|---------|--------------------------|--------------------------|--------------------------|-------------|--------------------------|
| Type unit | FP-20SE | FP-20T/TH | FP-40S | FP-40T | FP-80S | FP-80T | FP-100S | FP-200S | FP-500S | FP-1200/S FP-1200T/TS | FP-2000/S FP-2000T/TS | FP-3000/S FP-3000T/TS | FP-4200T/TS | FP-5700/S FP-5700T/TS |
| Total Number of units | | | | | | | | | | | | | | |

8 Preconditions in the Design of an Installation

The calculation must be performed separately for each compartment. Each compartment must be treated as a separate volume (eg. Suspended/false ceiling and raised floor). The Wall-Fire-Penetration-Fire-Flashover (WBDBO) of the room must at least conform to the prescribed legislation and building regulations. If a higher standing time has been calculated than the standard, the WBDBO must be adjusted to it. The doors must, in the event of fire, be self-closing and if necessary be activated by the control system. Windows, (smoke/heat) hatches and/or ventilation systems must be and remain switched off and closed during the extinguishing.

Leakage losses must have been considered and will, if necessary, form part of the calculation and siting. If the room is actually completely enclosed, any pressure displacement by the thermals is to be expected. Sufficient account must be taken of this. Description of what the room is being used for (e.g storage) must be included in the calculation and must be taken into consideration as part of the aftercare



Safe distances and height restriction.

A safe distance has been laid down in respect of (flammable) materials and persons for each individual FirePro unit in relation to the discharge of the aerosol. Its value is given in metres, as can be seen in the “Aerosol temperature and time of action table” under “Discharge temperature”. Here L2 is the safe distance from (flammable) materials and L3 from persons.

Apart from the safe distance a height restriction has been laid down for the protection of a room for each individual FirePro unit. If the aerosol exits from the unit vertically, the value of the discharge length of each unit is to be regarded as maximum height to be installed. Its value is given in metres, as can be seen in the “Aerosol temperature and time of action table” under “Discharge length”. If a different angle is used, the height must be reduced accordingly. For larger/higher rooms several units must be evenly spread, in accordance with the height restriction for each unit, over the whole room.

Direction of aerosol discharge.

The siting in the room according to Figure 3a is incorrect: the discharge opening is pointing towards a door. Consequently, aerosol will be lost in the course of extinguishing if the door is open. In the room according to Figure 3b the units are correctly sited.

Figure 3:

Figure 3a

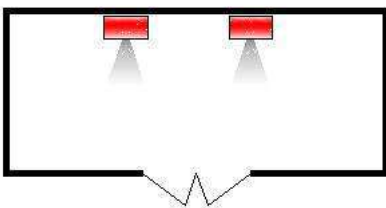

INCORRECT

Figure 3b

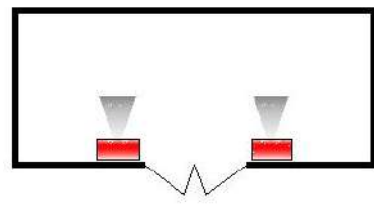

CORRECT

Technical Information

The tables below show the various technical aspects to be taken into account at the time of installation.

| Discharge length / Discharge Temperature / Discharge time | | | | | | | | |
|---|--------------------|---------|----------------------|----------------------------|-------|-------|----------------------|------|
| Ref. | Model | outlets | Discharge length (m) | Discharge temperature (°C) | | | Discharge time (sec) | |
| | | | | L1(m) | L2(m) | L3(m) | Min. | Max. |
| 1 | FP-20SE | 2 | 1.0 | - | - | 0.1 | 3 | 6 |
| 2 | FP -20T | 1 | 1.0 | - | - | 0.1 | 3 | 6 |
| 3 | FP-20TH | 1 | 1.0 | - | - | 0.1 | 3 | 6 |
| 4 | FP-40S | 2 | 1.0 | - | - | 0.1 | 4 | 8 |
| 5 | FP-40T | 1 | 1.0 | - | - | 0.15 | 4 | 8 |
| 6 | FP-80S | 2 | 2.0 | - | - | 0.1 | 4 | 8 |
| 7 | FP-80T | 1 | 2.0 | - | - | 0.1 | 4 | 8 |
| 8 | FP-100S | 1 | 1.0 | - | - | 0.3 | 5 | 10 |
| 9 | FP-200M | 1 | 2.0 | - | 0.1 | 0.4 | 10 | 15 |
| 10 | FP-200S | 1 | 2.0 | - | 0.1 | 0.4 | 5 | 10 |
| 11 | FP-500S | 1 | 3.0 | - | 0.3 | 1.0 | 5 | 10 |
| 12 | FP-500M | 1 | 2.0 | 0.7 | 1.10 | 1.5 | 10 | 15 |
| 13 | FP-1000M | 2 | 3.0 | 1.0 | 1.5 | 2.5 | 20 | 25 |
| 14 | FP-1200/S,1200T/TS | 1 | 3.5 | - | - | 1.5 | 15 | 20 |
| 15 | FP-2000/S,2000T/TS | 1 | 3.5 | - | - | 1.5 | 15 | 20 |
| 16 | FP-3000/S,3000T/TS | 1 | 4.0 | - | 0.6 | 2.0 | 15 | 20 |
| 17 | FP-4200T/TS | 1 | 5.0 | - | 0.6 | 2.5 | 15 | 20 |
| 18 | FP-5700/S,5700T/TS | 1 | 8.0 | - | 0.6 | 2.0 | 15 | 20 |

- L1** = Distance in metres between the outlet and the point where the temperature is > 400°C
L2 = Distance in metres between the outlet and the point where the temperature is > 200°C
L3 = Distance in metres between the outlet and the point where the temperature is > 75°C



Important!

The distances shown under discharge length are those to be regarded as a maximum installation height to obtain a rebound of discharge onto the surface (such as the floor) that then guarantees a good homogeneous spread of the aerosol in the protected compartment.

The temperatures shown under discharge temperature relate to the safety distances. In cases of storage of materials, cables, sensitive parts and/or the presence of persons, prevent them from coming into contact with discharges the heat of which is such that it can give rise to damage and/or injury.

The temperatures shown under discharge temperature relate to the distances and are also available in table 3 of the Kiwa Certificate. These shall also be used / implemented in the detailed design.

| Cylindrical Models | Activation | Weight in g | | Size (mm) | | outlets |
|--------------------|------------|-------------|----------------------|-----------|----------|---------|
| | | Gross | Mass of FPC Compound | Height | diameter | |
| FP-20SE | E | 310 | 20 | 165 | 32 | 2 |
| FP-20T | E | 310 | 20 | 165 | 32 | 1 |
| FP-20TH | TH | 310 | 20 | 165 | 32 | 1 |
| FP-40S | E | 610 | 40 | 140 | 51 | 2 |
| FP-40T | E & TH | 610 | 40 | 140 | 51 | 1 |
| FP-80S | E | 870 | 80 | 185 | 51 | 2 |
| FP-80T | E & TH | 870 | 80 | 185 | 51 | 1 |
| FP-100S | E & TH | 1370 | 100 | 155 | 84 | 1 |
| FP-200M | M | 1800 | 200 | 150 | 84 | 1 |
| FP-200S | E & TH | 1840 | 200 | 185 | 84 | 1 |
| FP-500S | E & TH | 3340 | 500 | 295 | 84 | 1 |
| FP-500M | M | 1800 | 500 | 150 | 84 | 1 |
| FP-1000M | M | 2240 | 1000 | 200 | 84 | 2 |

| Box Type Models | Activation | Weight in g | | D ₁ | D ₂ | D ₃ | outlets |
|-----------------|------------|-------------|----------------------|----------------|----------------|----------------|---------|
| | | Gross | Mass of FPC Compound | | | | |
| FP-1200/S | E | 10900 | 1200 | 216 | 300 | 167 | 1 |
| FP-1200T/TS | E & TH | 10900 | 1200 | 216 | 300 | 167 | 1 |
| FP-2000/S | E | 15500 | 2000 | 300 | 300 | 185 | 1 |
| FP-2000T/TS | E & TH | 15500 | 2000 | 300 | 300 | 185 | 1 |
| FP-3000/S, | E | 16300 | 3000 | 300 | 300 | 185 | 1 |
| FP-3000T/TS | E & TH | 16300 | 3000 | 300 | 300 | 185 | 1 |
| FP-4200T/TS | E & TH | 23600 | 4200 | 300 | 300 | 300 | 1 |
| FP-5700/S | E | 26400 | 5700 | 300 | 300 | 300 | 1 |
| FP-5700T/TS | E & TH | 26400 | 5700 | 300 | 300 | 300 | 1 |

Self-activation temperature of the FPC solid aerosol forming compound is approx. 300 °C

TH = thermal activation

E = electrical activation

M = manual (manual mechanical actuation)



Important!

The overviews below give an indication of the heat emission. You must take these temperatures and minimal free discharge parabolas into account when siting and installing. Positioning of the unit at the right angle can be very important in this regard.

The diagrammatic representations in Figures A, B and C are derived from the table in which the factors L1, L2 and L3 have been included.

The figure shown here gives the combination of colour and associated temperature.

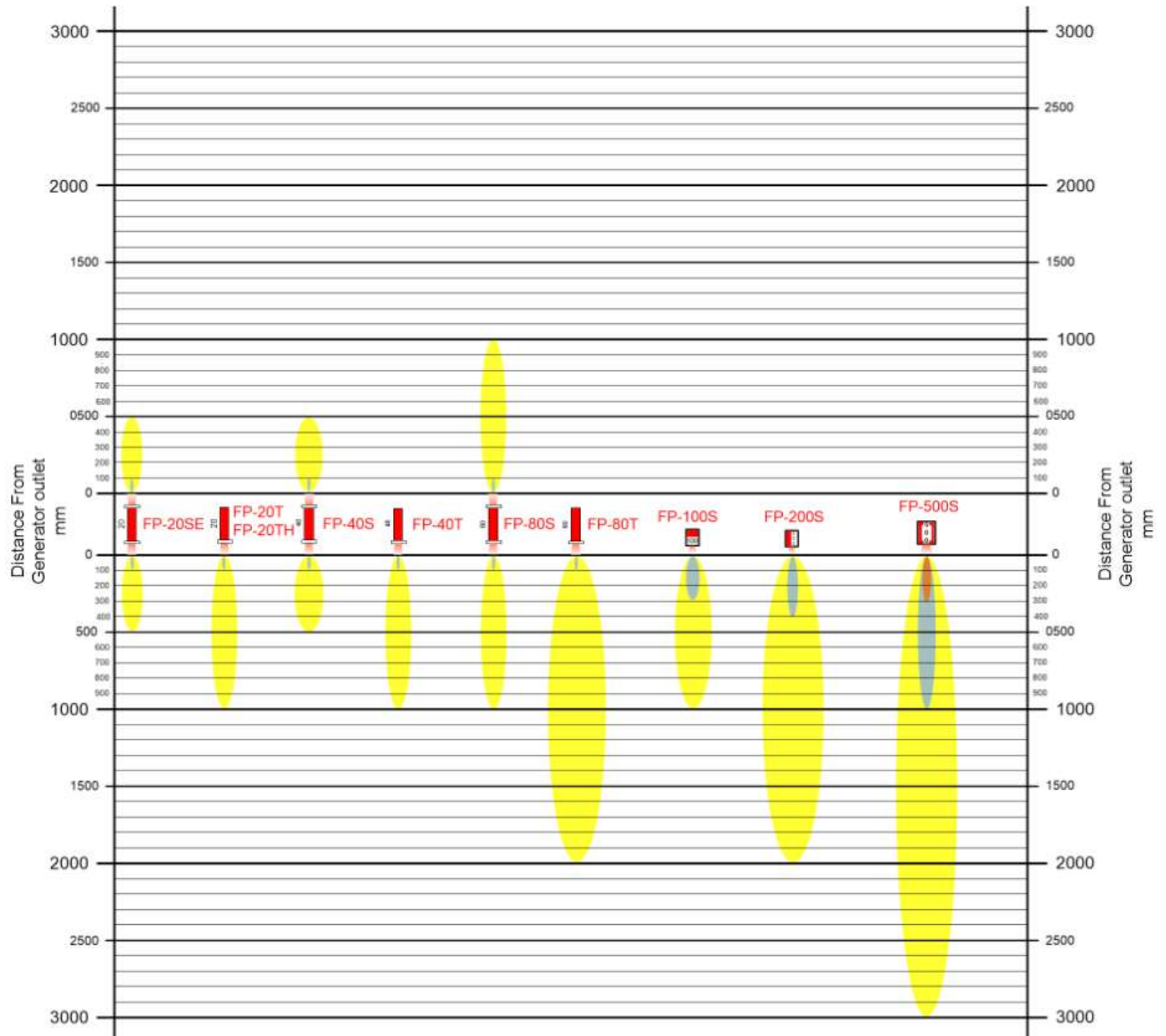
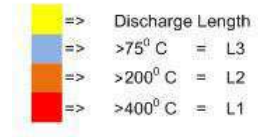

| LEGEND | |
|--------|---|
| | Maximum Height Of installation |
| | Minimum clearance from persons |
| | Minimum clearance from combustible materials |
| | Minimum clearance from construction structure |
| | Discharge Length |
| | >75 ⁰ C = L3 |
| | >200 ⁰ C = L2 |
| | >400 ⁰ C = L1 |

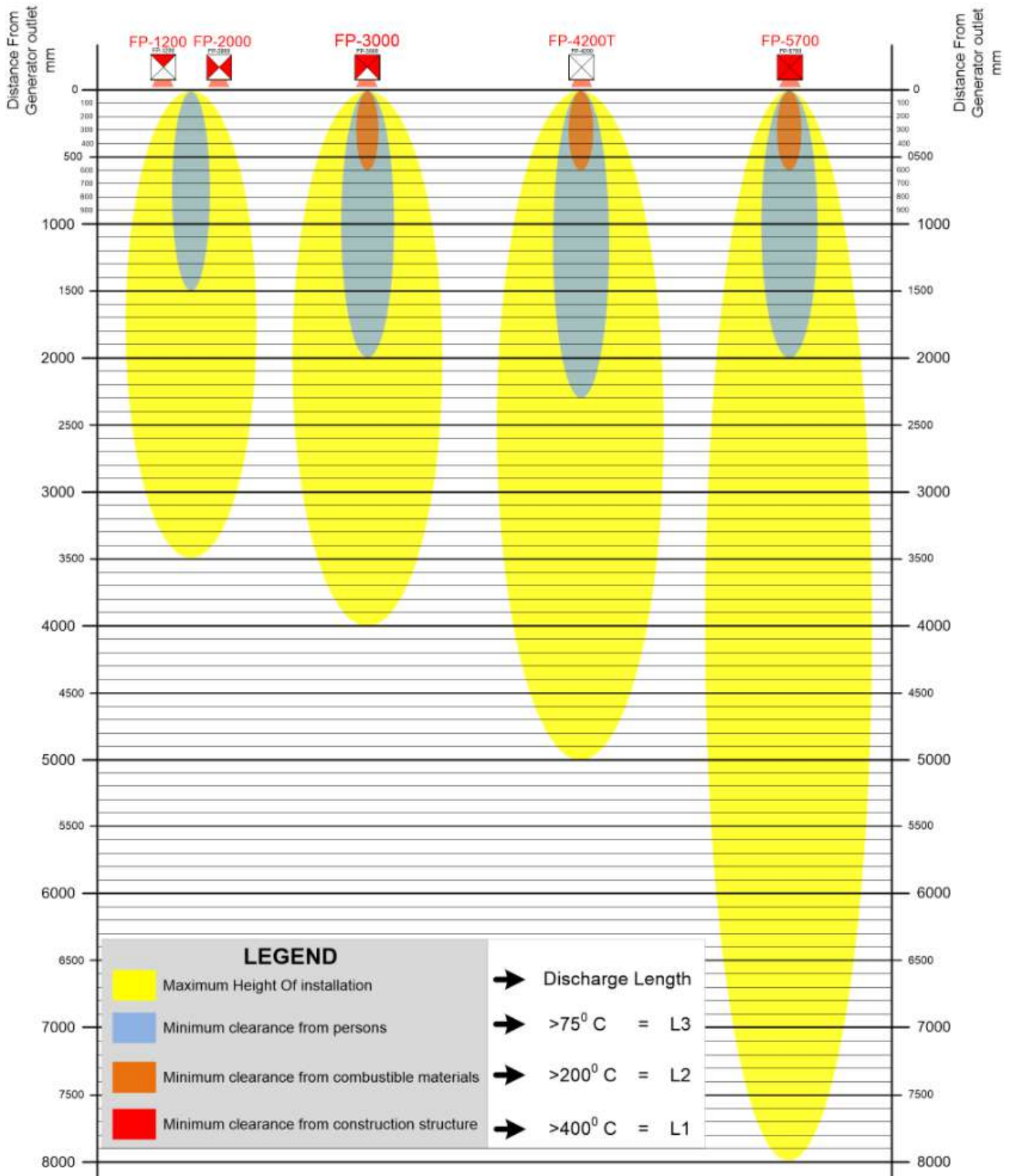

Important!



Sensitive equipment such as computers can react to great temperature differences. When extinguishing gases liquefied under pressure are injected into the room, cooling takes place. In the case of aerosol-forming units the temperature can rise. In both cases the restoration and maintenance of the temperature in the room concerned ($\pm 20^{\circ}\text{C}$) is important for the proper functioning of the sensitive equipment.

9 Activation Methods

Depending on the specific requirements FirePro units can be activated in the following ways:

- A. Manually: by means of an electrical impulse with a direct voltage from 1.5 volts or higher. This voltage is applied to the activator of the model E fire extinguisher using a manual release button; see **Figure 1**. The E models are equipped with the activator shown in chapter 9.2.

Figure 1:

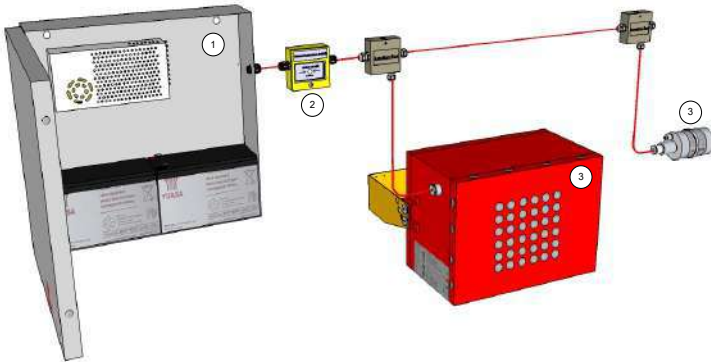

1. Power supply with output from 1.5 V DC or higher
2. Manual release button (Hand-operated switch)
3. FirePro condensed aerosol generators connected units

- B. Automatically: by means of heat, smoke or gas detectors, which are connected to a control panel. Here too the activation is electrical, as described above; see **Figure 2**. For more instructions regarding automatic activation, see chapter 10.1

Figure 2:

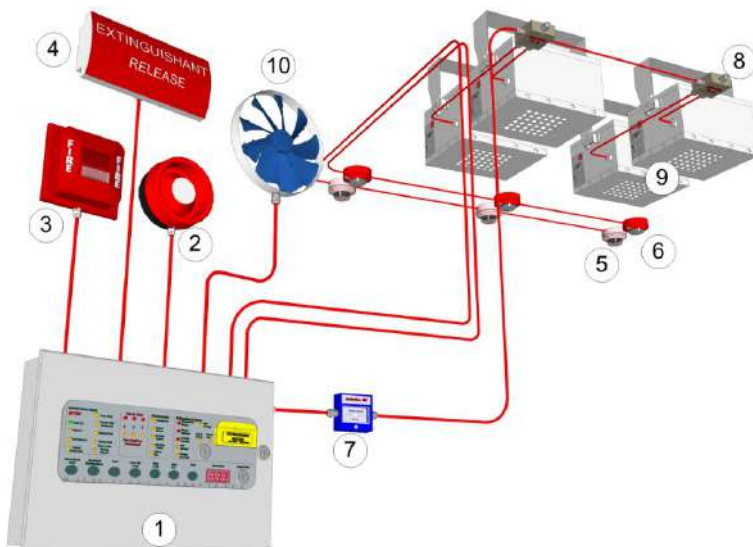

1. Extinguishing Panel
2. 1st Stage Sounder
3. 2nd Stage Sounder
4. Extinguishing Stop Indication
5. Zone 1, Smoke Detectors
6. Zone 2, Heat Detectors
7. System Isolation Switch
8. Sequential Activators
9. Condensed Aerosol Generators

- An E.P.O. System (Emergency Power-Off System) should be installed and activated prior the release of the fire extinguishing agent.
- Stage 1 Alarm: Air Dumpers, Ventilation System and Air-Conditioning to be powered off.
- Stage 2 Alarm: Emergency power off of all electronic & electrical equipment.

- C. Automatically (thermally): by means of a thermal actuator which is activated at a preset temperature.

9.1 Electrical Activation

E models:

The activator/initiator is connected to the activation power circuit through heat resistant wires. The applied power will activate the electrical coil (4) which will heat up the FPC Solid Compound thermal booster (5) initiating an exothermic reaction. The heat developed will transfer through the cylinder outlets (7) starting the exothermic reaction of the FPC Solid Compound (9) thus the thermal energy will be sufficient to start the reaction of the whole mass of FPC Compound contained inside the aerosol generator, transforming the FPC into a particulate (micro-sized particles) and carrier gases.

| Initiator cut-off view | | Legend | |
|---|---------------------------|--------------------------------------|--|
| | 1 | heat resistant wires (feed) | |
| | 2 | steel housing | |
| | 3 | polymeric resin | |
| | 4 | electric coil | |
| | 5 | FPC (solid compound-thermal booster) | |
| | 6 | chemical stabilizer | |
| | 7 | cylinder with 2 outlets | |
| | 8 | sealing | |
| | 9 | FPC (solid compound) | |
| | 10 | lacquered surface | |
| Electrical values | | | |
| Bridge resistance | 1.6-3.0 Ohms (Ω) | | |
| Minimum Pulse Energy | 0.8 mWs/ Ω | | |
| Minimum Pulse Voltage (V) | 1.5 Vdc | | |
| Minimum Pulse Current (A) | 0.8 A | | |
| Minimum Pulse Duration | 0.5 s | | |
| No Fire Current (A) | 0.02 A | | |
| Duration of Heat Emission | 3 - 4 s | | |
| Working temperature (not to be exceeded) | | | |
| Deployment temperature | -54° C to 100° C | | |
| Storage temperature | -54° C to 54° C | | |
| | | | |
| <p>The initiator is a standard component of all the FirePro aerosol generators</p> | | | |

9.2 Thermal Activation

TH or T models: with these models the activation takes place automatically by means of the thermal actuator which, as soon as the temperature reaches a preset level, activates the FPC aerosol-forming extinguishing solid compound.

For lower activation temperatures other types of detector can be used that are connected to the fire extinguishers through the fire alarm panel. In this case the thermal actuator is used as activation setting with the effect of a safety valve that activates where other detectors fail to activate the system.

9.2.1 Methods of Thermal Activation

A. Bulb Thermal Actuator (BTA)

Technical Information

- Bulb according to BSEN12259, UL199, LPCB 291A/02
- Thermal Actuator consists of (a) Thermo Lock with Glass Retort, (b) Spring Transmission of percussive mechanism, which initiates the capsule, (c) Safety Ring and Pin during transportation
- Temperature Rating in °C: 57, 68, 79, 93, 141, 182
- Bulb Colours: Orange 57°C, Red 68°C, Yellow 79°C, Green 93°C, Blue 141°C, Mauve 182°C
- Length 20mm, Diameter 3mm
- During operation the liquid within the bulb will expand until the required operational temperature is reached. At this point the glass bulb will 'burst', allowing the thermal mechanism to actuate the built-in firing pin, which in turn initiates the capsule, and causes ignition of the FPC solid compound in Generator activator
- Strength (Crush Load), kN, 4.1
- Response Time Index RTI 24m/s
- Precise calibration of the bulbs during production enables accurate operating temperatures to be achieved
- The surface area of the glass is maximised to allow optimum conductivity of heat from surrounding air to bulb liquid
- The super fast THERMO BULB is a high-performance fast response THERMO BULB featuring improved strength and sensitivity characteristics. The response time is 25% faster than that of the standard fast bulb with superior strength condition.



Assembly Procedure



B. Bimetallic Actuation kit (FPC-5)

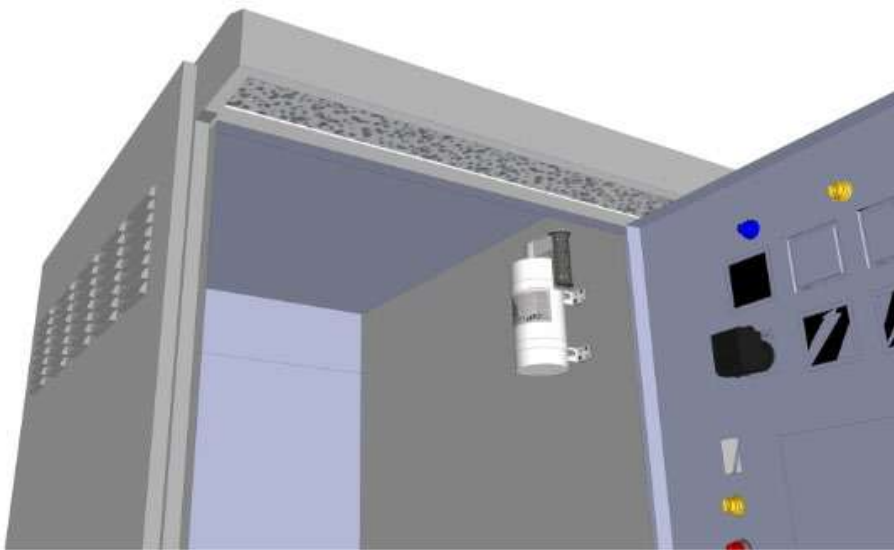
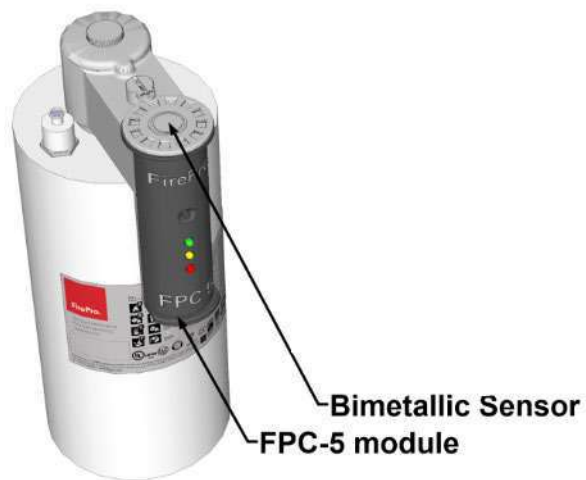

Detailed information can be found in FPC-5V2 Operation and User Manual

C. Linear-Heat-Detection-Cable Actuation kit (FPC-5)

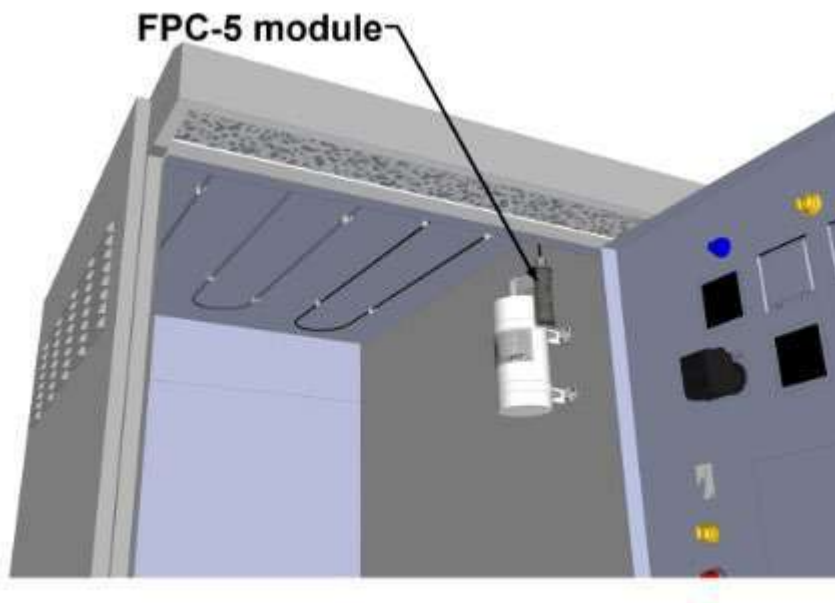
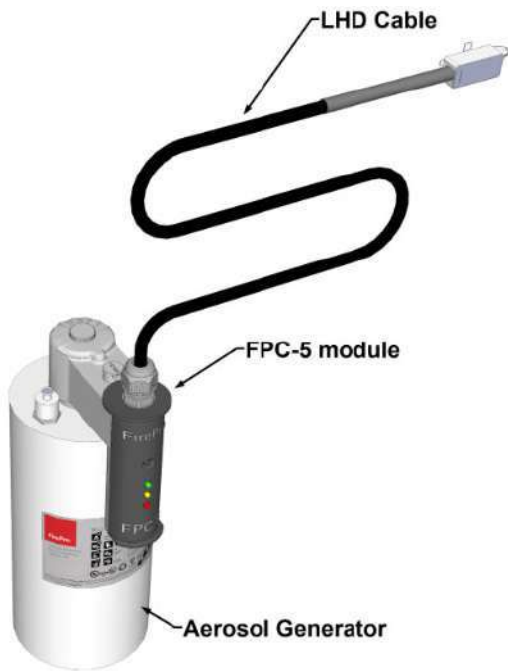

Detailed information can be found in FPC-5V2 Operation and User Manual

10 Preparation for Installation

- Make a visual inspection of the exterior of the FirePro unit.
- Use a measuring device (ohmmeter) to ensure that the internal electrical resistance of FirePro electrical activator is between 1.6 to 3.6 Ohms.

10.1 General Guidelines for Installation of Fixed System

Fire detection and alarm/evacuation installation

Basic principles:

- Building Decree
- NEN-2535 Fire safety of buildings - Fire detection installations - System and quality requirements and guidelines for detector siting, including amendments or equivalent EN Standard
- EN-54 parts, with regard to fire alarm equipment.
- NEN-2654 Management, control and maintenance of fire safety systems, part 1 & 2 or equivalent EN Standard
- "Installing a fireproof building" 2nd edition of the Dutch Fire Brigade Federation or equivalent.
- European low voltage and EMC directives (CE mark)
- NEN-2575 Fire safety of buildings – Evacuation installations – System and quality requirements and guidelines for siting
- Any standards or directives other than those mentioned above that must be observed in the country where FirePro is installed.
- Central panel, detection and activation components prescribed by FirePro or according Kiwa BRL-K23003.

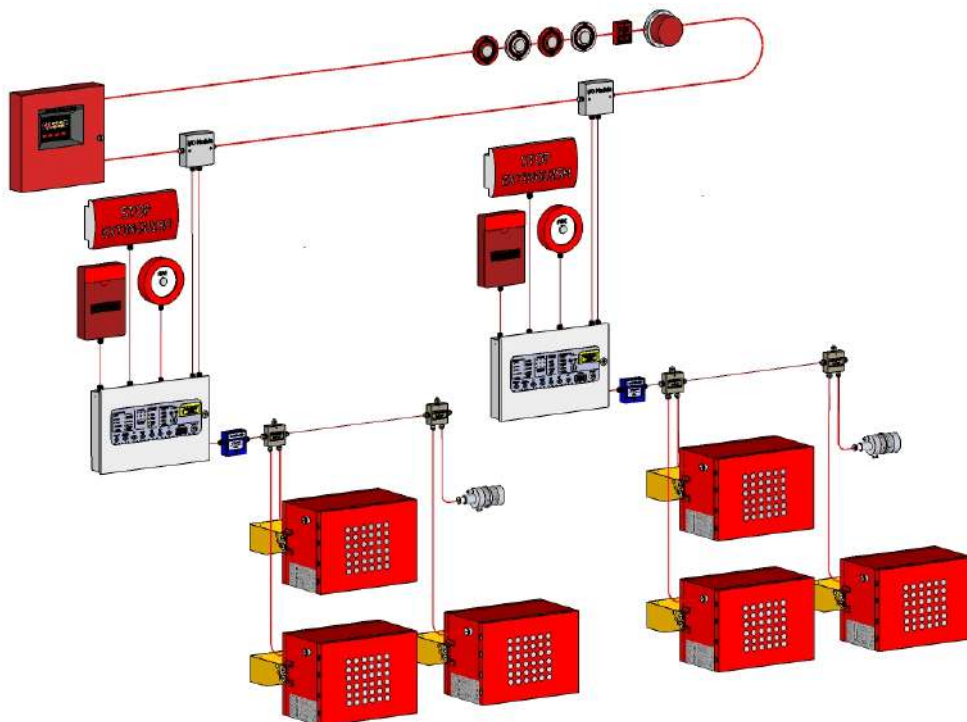

10.2 General

To give users the opportunity to evacuate the building promptly when a fire is in its early stages or to report it to the fire brigade, a number of technical installations must be installed in the building for this purpose.

The performance requirements of the fire detection and alarm/evacuation installation must be clearly formulated in accordance EN 54.

The execution drawings, description and any certificates of the installations referred to in this report must be submitted in detail to the municipal authorities for approval before the installation is completed.

Performance requirement.....: nuisance and false fire alarms, depending on the type of building in accordance with EN 54

Performance requirement : for system availability, depending on the project in accordance with NEN-2535: §4.4 or equivalent

Detector siting in accordance with EN 54 or equivalent with a two-detector dependence for the prevention of unwanted extinguishing by the extinguishing system.

If compartmentalised extinguishing must take place within the same room, allowance will have to be made for the detection. Here detection must be by means of thermomaximal or thermodifferential detectors

Once there has been a calculation of the number of FirePro units and of the models to be installed for the protection of a given volume or object (see calculation method), it is important for the correct location of the fire extinguishers to be determined.

The units can be installed on walls or (suspended) ceilings, in cubicles, etc. For vertical installation on walls there must be a safe distance of at least one metre from gangways, racks or objects. For the larger models of FirePro units there must be a greater distance. The same applies for horizontal installation on ceilings; in this case lateral distances must always be taken into account.



Do not install any FirePro units between the possible place of combustion and points by way of which the excess pressure of the objects can disappear: doors, skylights, man-holes, windows, covers, etc. (see Figure 3). The installation of FirePro units in the vicinity of openings is not recommended.

FirePro units that are used for the protection of specific objects must be installed so that during the operation of the extinguisher the room can be filled with the extinguishing aerosol from the underside of the object.

The optimum distance from the floor of the protected volume to FirePro units is shown by way of the flow parameters in the catalogue with technical information. The discharge of the aerosol shall not be impeded by objects at the exit outlet of the aerosol fire extinguisher (see table "technical information", heading "discharge temperature", page 37).



Note:

It is also important that, if there are objects placed too close to the discharge opening, they may be damaged by a high aerosol temperature. To prevent damage to objects steps must be taken to ensure that a safe distance is maintained in a straight line from the aerosol discharge opening. This can be derived from a table called "temperature and activation time". In this table temperature is plotted against distance. This is for each model.



Important: Ensure that no dirt, oil, corrosive substances and other contaminants can find their way into the FirePro units.

The FirePro units must be placed in the room in such a way that in the event of fire the aerosol flow does not form an obstruction to the evacuation of personnel. The room in which the fire detection and fire alarm control unit and fire brigade panel are set up must be equipped with general lighting with a lighting intensity of not less than 100 and not more than 500 lux and emergency lighting with an intensity of not less than 1 and not more than 10 lux (or other specifications if given by the local guidelines).

The fire detection and fire extinguishing control unit must comply with EN12094-1, to be demonstrated by means of a product certificate from an accredited European certification body (or in accordance with local guidelines).

The function of the control switches (push buttons), signal lamps and all the relevant inscriptions and texts must be applied clearly, permanently non-erasable and in the language of the user. The inscriptions must be clearly legible at a distance of 80 cm. The control functions of the fire detection and fire alarm control unit that have fundamental consequences for the operation of the system, such as the switching off of detector loops, switching on/off of delayed transmission, etc, may not be operated by unauthorised persons.



If a manual switch is installed for the electrical activation, its location must be accessible. It must also be in a place where it is impossible to activate it accidentally.

10.3 Emergency Fire Detection and Fire Alarm System Power Supply

The fire detection and fire alarm system must be connected to a separate end group, which is provided with the notice:

“DO NOT SWITCH OFF FIRE DETECTION & FIRE ALARM SYSTEM”

The fire detection and fire alarm system must be equipped with its own emergency power supply, consisting of a battery charging circuit and batteries. The fire detection and fire alarm control unit (BMC) must also have primary and secondary power supply (emergency power supply) monitoring; faults in the power supply must be reported both visually and acoustically.

The primary power supply and emergency power supply of the BMC must be calculated so that the entire installation including the equipment to be operated is fed.

The primary power supply and emergency power supply of the common fire detection and fire alarm system must have sufficient power:

- For the flashlight (which indicates the fire brigade entrance)
- For the slow whoops (the evacuation installation)
- For the transmission equipment (if this is not equipped with its own emergency power)



Important: if the standard power supply/emergency power supply is not sufficient, then expand the emergency power supply.

The emergency power supply of the BMC shall be designed based on:

- The maintenance contact according to NEN-2654;
- Automatic fault transmission to a 24-hour monitored alarm post within 30 minutes;
- Autonomy time emergency power supply for evacuation alarm is 23.5 hours at rest and 30 minutes in alarm condition;
- Rectification of fault by the fire detection company must be guaranteed within 24 hours.

The emergency power supply of the common fire detection and fire alarm system shall be able to simultaneously control the following components for 30 minutes:

- Flashlight
- Acoustical alarm units
- FirePro Aerosol generators (all)



Important: Battery ageing must be taken into account when determining the necessary battery capacity (use only approved batteries).

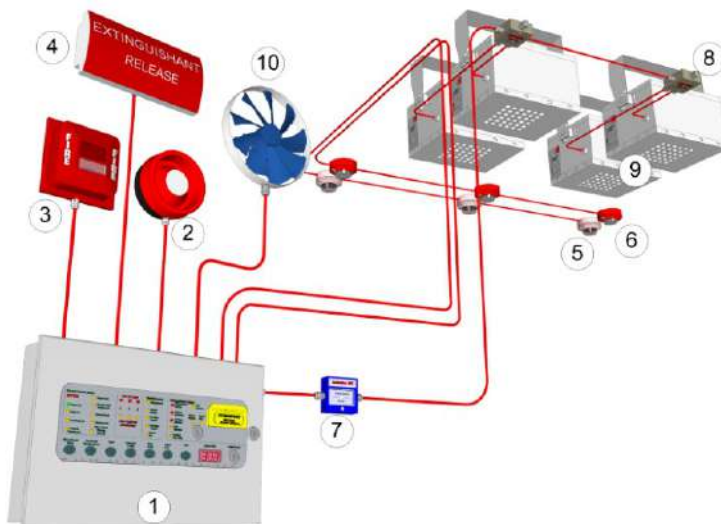

1. Extinguishing Panel
2. 1st Stage Sounder
3. 2nd Stage Sounder
4. Extinguishing Stop Indication
5. Zone 1, Smoke Detectors
6. Zone 2, Heat Detectors
7. System Isolation Switch
8. Sequential Activators
9. Condensed Aerosol Generators

- An E.P.O. System (Emergency Power-Off System) should be installed and activated prior the release of the fire extinguishing agent.
- Stage 1 Alarm: Air Dumpers, Ventilation System and Air-Conditioning to be powered off.
- Stage 2 Alarm: Emergency power off of all electronic & electrical equipment.

11 Installation Procedure

The FirePro units are fixed using brackets. For FirePro units with a discharge opening on one side, the brackets must be guided over the middle of the container. For FirePro units with a discharge opening on two sides, two matching brackets are used which are fixed on the container at a distance of $\frac{1}{4}$ of the overall length of the container from each end. Tighten the bracket clamping bolts.



Important: In the case of installations in rooms where vibrations can occur, because of motors for example, the units must be fixed to a vibration-free base. Examples include rubber blocks or other similar materials.

Ensure that the FirePro unit is properly secured.

Before starting on the installation of the FirePro units, check that all the parts required have been supplied.

Then go to work in this order:

- a) connect the wires to the terminals of the FirePro units;
- b) connect the wires to the parts of the fire extinguishing system;
- c) finally connect wires to the power supply.

Following completion of the work, check that the FirePro units have been installed correctly, that is, that all the requirements in the installation instructions have been met. If required, you must record the installation on the installation certificate or in the technical documentation of the protected object. The distributor reserves the right to inspect the installation. The installer is at all times obliged to cooperate with this. A distributor and/or installer should, preferably, be certified according Kiwa BRL-K23003.

11.1 Cabling/Installation

Wiring

All wiring systems shall be installed in compliance with local codes and the system drawings.

A UL Listed Liquid-tight Flexible Metal Conduit Fitting, Model Number 3402-8 or 3402, manufactured by Raco/Hubble is to be used by the installer for the wiring of 1/2 inch trade size liquid-tight flexible metal conduit for all FP Series condensed aerosol generators.

These fittings may be obtained by FirePro – Part No. 11053 *Liquid-tight Flexible Metal Conduit Fitting (3402)* or **sourced locally or directly from manufacturers**. These fittings are to be torqued to a value of 25 N-m during installation.

An indicative installation diagram is shown below

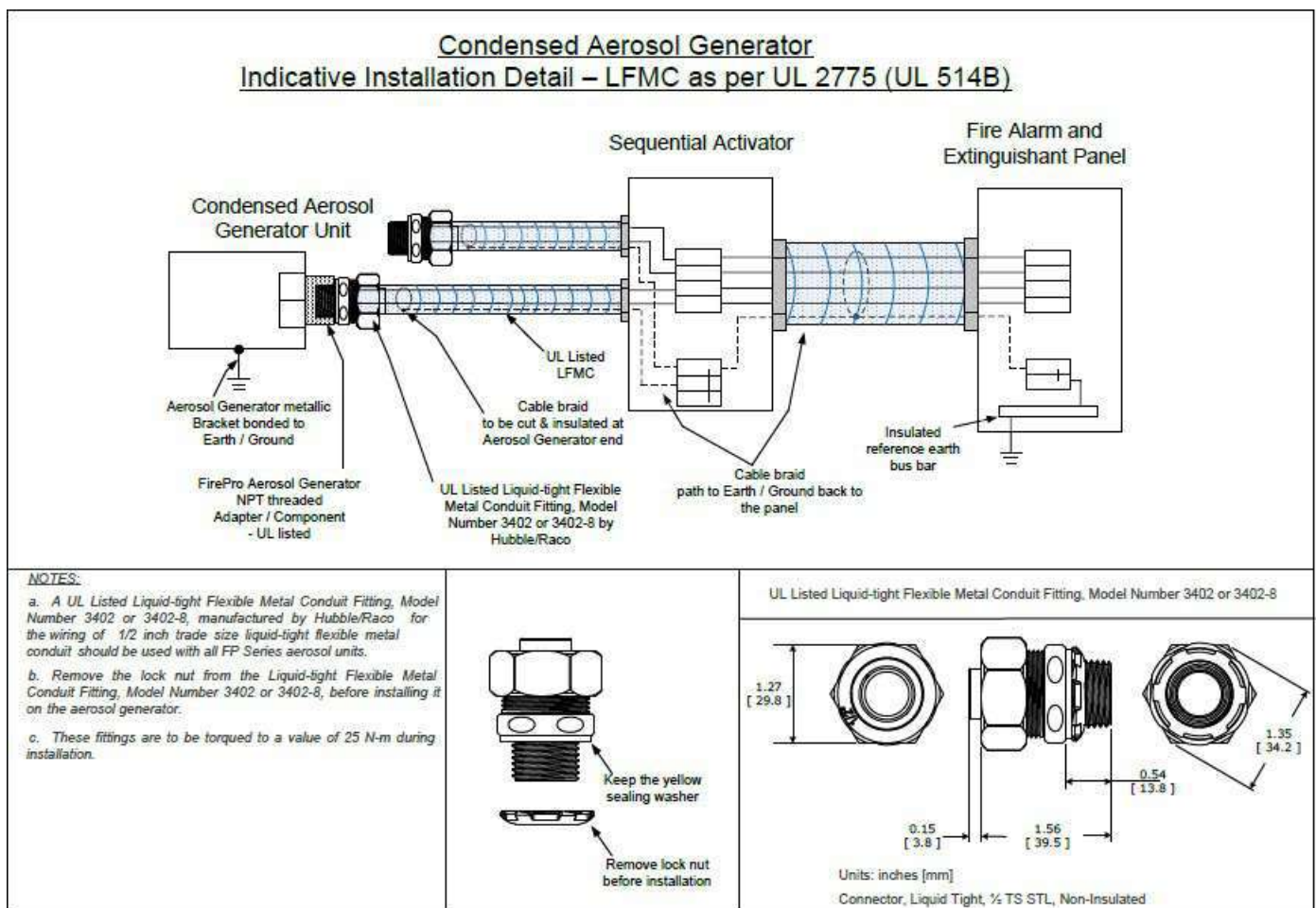

Mounting and connecting of cables and components of the entire fire protection system is the responsibility of the installer.



Note: the execution mounting and connecting of cables and components shall comply with EN 54, NPR2576 and NEN-1010 (last edition and including amendments).

Fixed cabling for main current (230 V) must have a minimum conductor cross section of 1.5 mm. The cabling must be of flame retardant construction (NEN-1010), provided that no function retention is required. All the cables that are part of the fire detection and fire alarm system and evacuation installation must be red or be marked red every five metres. Cables in a terminal box must be provided with a loop, group and cable number.

Only lay cabling in a conduit or a compartmentalised cable duct:

- In cable ducts a division plate or 50 mm spacing is required between the fire detection and fire alarm system cabling and the 230/380 V power current cabling;
- In cable ducts control current cabling may be laid with fire detection and fire alarm cabling if no disruptive mutual interference is to be expected;
- Conduit must connect to the cable duct;
- Open bends, maximum 50 x 50 mm, are only permitted above suspended ceilings and beneath raised floors;
- Protect conduits emerging from floors with impact-resistant conduit to 10 cm above the floor.

Where cabling is laid directly alongside power current cabling, for example next to motor cables of an air conditioning system, then use screened or twisted cabling, lay in separate compartments or keep a minimum of 50 mm spacing between power current cabling and fire detection and fire alarm cabling.

Where cabling is laid through fire-resistant partitions, suitable measures must be taken to ensure that the fire/smoke-resistance of the partition is not impaired.

The wiring, technology and tools used must be used according to the requirements of approved workmanship, with the aim of minimising the chance of failure. Do not include any conductors in the fire detection and fire alarm system cabling that are fed from other installations.

There may not be any joints in transmission paths, unless in consultation with the fire detection company and the local fire brigade. The joints must then be made in terminal boxes intended for the purpose. Any joints necessary must be housed in a completely sealed junction box. The conductors must be connected to the terminal strips with numbered screw terminals.

A distributor and/or installer should, preferably, be certified according Kiwa BRL-K23003.

11.2 Circuit integrity under fire conditions

The route, execution, mounting and connecting of cables and components should be chosen so that the chance of damage by fire and/or falling constructions/elements is prevented and/or is as small as possible.

This can be achieved by:

- Laying cable in the ground.
- Laying cable in a 30 minutes fire-resistant enclosure.
- Making use of fire-resistant cable (cable must conform to DIN 4102 Part 12 class E 30 or equivalent).
- Making use of other parts of NPR2576; Circuit integrity under fire conditions - Guideline for cable laying, construction and mounting of transmission paths or equivalent

The following cables are concerned:

- Between the fire detection and fire alarm control unit and signal transmitters (Acoustical alarm units and flashlight).
- Between the fire detection and fire alarm control unit and the transmission equipment.
- Between the fire detection and fire alarm control unit and the fire brigade panel and any additional panels.
- Between the fire detection and fire alarm control unit and any control that automatically resets when the BMC central panel is reset.

The cable supports or brackets for which function integrity is required shall also remain functional for 30 minutes in the event of fire.

A distributor and/or installer should, preferably, be certified according Kiwa BRL-K23003

11.3 Cable Monitoring

Cable monitoring according to NEN-2535

In addition, the following cabling must be provided with cable monitoring:

- Cabling to the transmission equipment if longer than 1.5 m.
- Cabling to the FirePro unit.
- Acoustical alarm units.

11.4 Shutdown of Energy Supply and Computers



The activation system of the FirePro units is to be planned so that the following expectations/conditions are met:

- The ventilation system of the room to be protected must be shut down before the FirePro System is activated. The power supply to the equipment/installation must also be shut down so that the ventilation and/or blowing function of the equipment is stopped. In this situation the fire cannot spread by means of extra oxygen and the extinguishing agent can reach the fire with guaranteed swiftness and in the desired concentration and extinguish it efficiently.
- The shutdown system for the power supply also guarantees that there is no short circuiting following activation. Any additional fire risk is prevented by the shutdown system.
- The shutdown system for the power supply and ventilation is connected to the fire detection and fire alarm system and/or fire alarm panel.

12 Installation, Installation Tests, Delivery, Inspection and Maintenance

12.1 Installation

The Schedule of Requirements with the execution drawings and any other relevant descriptions and/or certificates of the fire detection and fire alarm system must, before the installation is installed, have been approved by the local authority. Usually this will be the local chief fire officer of the municipality in which your business is located.

The fire detection and fire alarm system shall be supplied and also maintained by the authorized FirePro dealer or by a fire detection company that has been certified by Kiwa or equivalent.

The fire detection and fire alarm system must be installed by an expert and recognised installer. The installer must work in accordance with the requirements of certification under the responsibility of the authorised FirePro dealer or the fire detection company (supplier of the fire detection and fire alarm system).

The authorised FirePro dealer, the installer and the specialised fire detection company may depart from the provisions of this schedule of requirements, if and in so far as approval has been granted by all the required parties and the author has drafted revisions for this schedule and has been correctly informed to this effect.

Where the schedule of requirements differs from applicable standards, guidelines or directives, the schedule of requirements shall prevail. The installer must ensure that before the start of work the design and the siting of the installation has the approval of the local authorities, customer and owner.

Following acceptance of order, on the basis of perusal of the respective (definitive) text and drawing of this schedule of requirements, the authorised FirePro dealer and/or the specialised fire detection company is responsible for the design and the installation of the fire detection and fire alarm system.

If and in so far as can subsequently be concluded that the actual situation differs or has become different from that on which the schedule of requirements is based, in particular where the intended use of the rooms is concerned, the owner/user of the installation and/or whoever installs the fire detection and fire alarm system must adapt the fire detection and fire alarm system to the newly arisen situation. Advice can be requested from FirePro Systems Ltd. if this situation arises.

In the event of any subsequent modification (including structural) of layout having an impact on the speed and reliability of fire detection and the fire alarm, the fire risk and/or on the chance of nuisance alarm/fault, consideration must again be given to whether an adjustment of the fire detection and fire alarm system is necessary and/or required (such as detector siting and detector choice). Any adjustment, for the above reasons, must be approved by all the parties concerned and/or required. This approval must be incorporated into the schedule of requirements.

A distributor and/or installer should, preferably, be certified according Kiwa BRL-K23003 or EN 15276-2.



Important: If and in so far as the manufacturer's installation instructions differ from the schedule of requirements, for a careful implementation of the FirePro products contact must first be made with FirePro Systems Ltd. Primarily the installation instructions of the manufacturers and/or fire detection and fire alarm control unit and/or detection material must be followed.

12.2 Installation Tests and Delivery

Following commissioning and installation an attestation (a written confirmation of approval) stating that the installation is working properly and conforms to all the technical descriptions must be issued by the installer/the fire detection company. At the time of delivery the fire detection company must supply the materials required for testing the detectors used.

12.3 Maintenance and Inspection

During the period that the FirePro units are in use the following inspections and maintenance procedures must be carried out:

A periodic inspection of the aerosol fire extinguishers and fire extinguishing systems to check the following parts:

- | | |
|---------------------------|---|
| 1 – electrical wiring | 4 – terminals of the electrical activator |
| 2 – electrical circuit | 5 – electrical contacts |
| 3 – thermal actuator port | 6 – fixing bolts |

At the time of the final inspection the following documents must be issued:

- Schedule of Requirements
- Installation attestation conforming to EN 54 (or any other equivalent local standard)
- Brief and concise operating instructions, approved by the fire brigade
- Logbook of the fire detection and fire alarm system
- Revision drawings in triplicate with all the relevant details
- A signed maintenance contract

The authorised FirePro dealer must provide a separate quotation for inspection, management and maintenance of the FirePro-based installation. The installer of the fire detection company must alert the customer to its obligation to carry out limited functional installation tests and maintenance, including a monthly functional test of the installation and transmission. This must be in accordance with EN 54 (or an equivalent local directive). The customer must ensure that this task is undertaken by a suitably trained officer under EN 54 (or an equivalent local directive).

The customer/user is obliged to conclude a maintenance contract in accordance with NEN-2654 (or an equivalent local directive) with the authorised FirePro dealer. This maintenance can for example stipulate that the installation be inspected and maintained annually.

The maintenance contract must state:

- that the maintenance will be in accordance with EN 54 (or an equivalent local directive)
- that maintenance will be undertaken during the life of the installation
- that the service provider will start on the rectification of a fault within 24 hours of receipt of a fault report
- and urgent interventions must also be included in the maintenance contract

The suitably trained officer of the authorised FirePro dealer or the customer/user must keep a logbook, recording all the relevant events concerning the installation, such as false and nuisance alarms with any cause, switching off of detectors, detector groups, maintenance, inspections and installation tests, adjustments, expansions and repairs. Other areas of attention are:

A periodic test (see maintenance) for E models; the resistance measurement must be carried out to check that the internal resistance of the activator is between 1.6 to 3.6 ohms. This test must be carried out with a suitable and calibrated measuring device.

All the electrical wires and connections of the FirePro units to the control panel or the switch must also be tested and checked.

A periodic inspection of the metal casing (see maintenance) of the solid extinguishing agent must be carried out to check whether the material is intact or has been damaged by chemically aggressive materials or corrosion. Whenever such inspection indicates that the metal casing has been damaged, the unit shall be replaced.

All the metal brackets and connecting bolts must be inspected and tightened.

Thanks to its chemical composition and properties the aerosol-forming extinguishing compound FPC (FirePro Compound) in the FirePro units does not require any further maintenance throughout its life.

Product life: the Certified Product life of the FirePro units is 15 years.

Logbook

The logbook contains all items required to provide a clear overview for the fire extinguishing system and for the recording of various occurrences during the total lifespan of the installation. The logbook shall consist of the following:

Content of logbook:

- Introduction
- General details
- Devices used
- Management and maintenance requirements
- Measures on system activation
- Measures following system activation
- General rules and regulations for the user

In the appendices:

- Periodic checks trained person
- Periodic check by maintenance expert
- Overview of automatic fire extinguishing system statistics
- Overview of periodic checks and preventive maintenance
- Overview of real fire statistics
- Overview of nuisance fire alarms
- Overview of false fire alarms
- Overview of system availability
- Safety information sheet
- Technical data FirePro units
- Certificate of delivery
- Installation drawings
- Schematic diagrams
- User instructions for BMC (fire detection and fire alarm control unit)
- Inspection reports

A distributor and/or installer should, preferably, be certified according Kiwa BRL-K23003 or trained by FirePro.

12.4 Drawings and Pictograms

When drafting the technical drawings work to scale and clearly indicate the rooms to be protected.

Indication drawings for rooms to be shown.

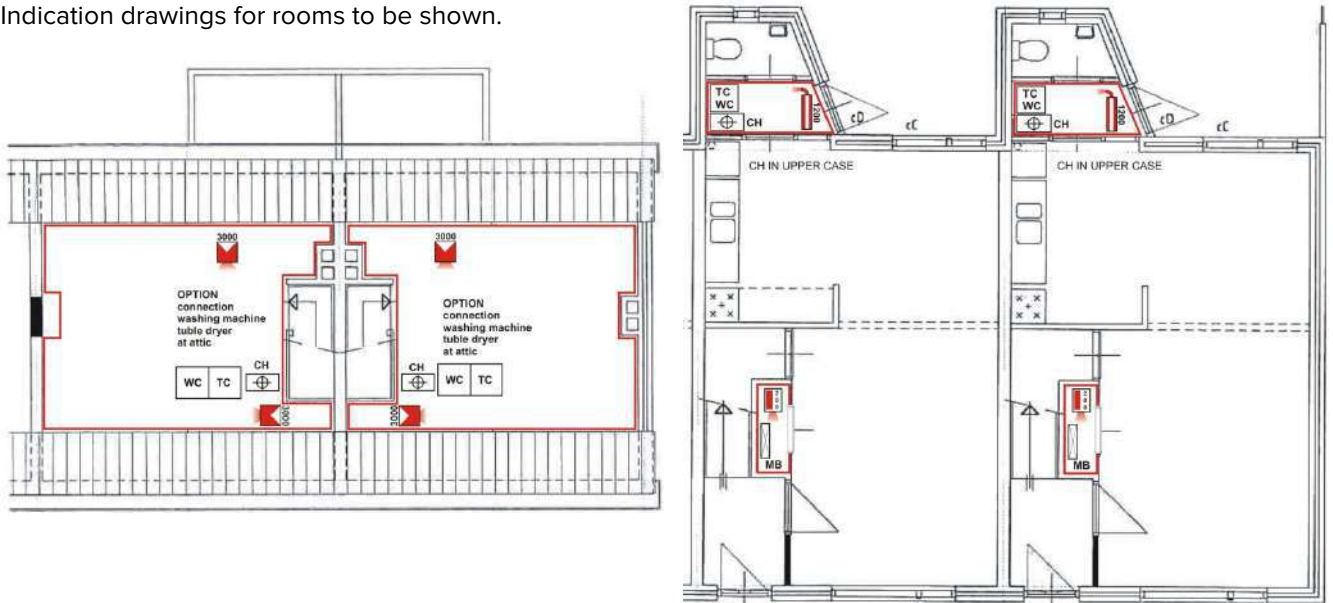



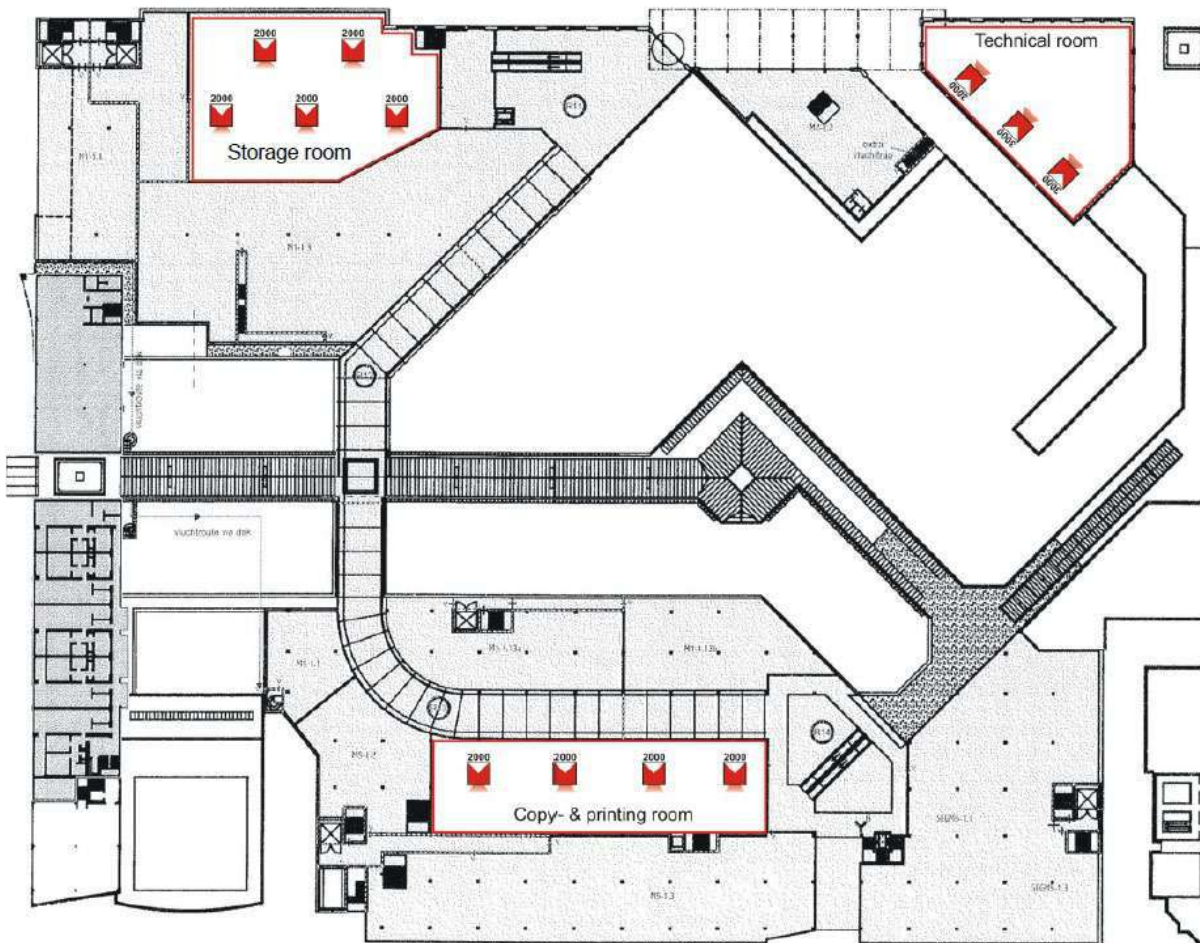

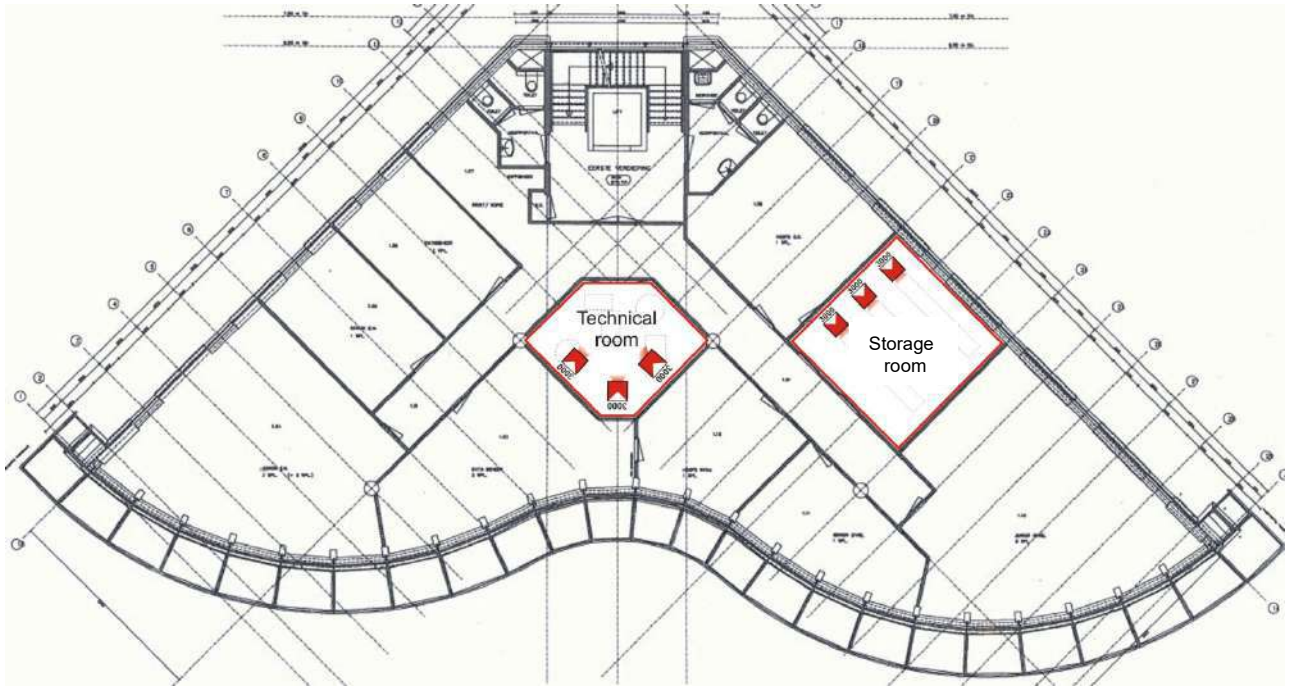



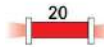



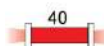

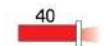

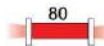

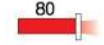
Important: Use the correct pictograms in the siting and the ultimate overviews.





When making installation drawings and/or indications on situation diagrams and/or (evacuation) plans the pictograms below must be used.

| | | | |
|---|-------------------|---|--------------------------|
|  | FP-20SE |  | FP-500S |
|  | FP-20T FP-20TH |  | FP-500M |
|  | FP-40S |  | FP-1000M |
|  | FP-40T |  | FP-1200/S FP-1200T/TS |
|  | FP-80S |  | FP-2000/S FP-2000T/TS |
|  | FP-80T |  | FP-3000/S FP-3000T/TS |
|  | FP-100S |  | FP-4200T/TS |
|  | FP-200S |  | FP-5700/S FP-5700T/TS |
|  | FP-200M |  | FPC-3 |

13 Residue, Removal, Dismantling of Units, Waste and Environment

13.1 Residue

During the activation process the FPC changes into a swiftly spreading aerosol, consisting of solid particles that are suspended in the gas phase. The size of these particles is a few micrometres/nanometres.

The composition of the FirePro aerosol, consisting of potassium compounds, is, in the intended concentration, not corrosive, not electrically conductive and does not cause any damage to the equipment protected. The FirePro aerosol-forming compound is not based on halogen compounds that react with the fire. It does not produce any corrosive halogen acid by-products in its reaction with the fire.

The concentration of solid particles suspended in the aerosol phase is a few milligrams per m³. The particles are free from water and moisture and after a given period of time settle as dust in the protected room. The dust can easily be removed during cleaning before it absorbs moisture.

Regarding the side effects of fire following the extinguishing, which mainly consist of KOH in a very low concentration (which again reacts with CO₂ and rapidly change into K₂CO₃) and are also free from water and/or moisture, the same considerations are applicable to the aerosol particles.

If the aerosol particles are removed by cleaning shortly before they can absorb moisture and the mix of combustion residues present in the air after the fire, they do not react to electronic components, metal etc. Where the dust particles remain for a long period, they can absorb moisture, meaning that the moisture will react with metal (especially unpainted or untreated) so that oxidation could occur.

Important!



When extinguishing gases liquefied under pressure are sprayed in the room cooling takes place. In the case of aerosol-forming units the temperature can rise. Both processes affect the humidity. It is therefore important to be aware of the humidity present beforehand. Following fire and/or activation of the extinguishing system the humidity in the room must be reduced as soon as possible.

13.2 Guidelines for the Removal of the Residue



Note:

- Remove the residue shortly after activation (within max. a few hours).
- Use a damp cloth or brush to mop up the dry residue from the floor and/or metals.
- Use a fan to remove the residue from electrical components.
- Use special sprays that are suitable for removing/cleaning the residue from electronic components.



Important: following a genuine and/or nuisance activation of the FirePro unit(s), you must always contact your dealer who can help you with a new survey of the room concerned and the correct reconditioning or cleaning methodologies.

13.3 Dismantling

When the FirePro units have to be dismantled, the following steps must be taken:



- completely switch off the drive from the fire detection system and ensure that it cannot be switched on;



- undo the power supply wires on the FirePro unit and ensure that they cannot be connected;



- ensure that you are standing firmly and adhere to the rules for working at height (Working Conditions Act);



- undo the FirePro unit by undoing the bolts and nuts;



- carefully remove the unit from the bracket and place it on a stable surface;



- after dismantling the FirePro unit(s), put the fire detection and alarm installation back into operation in consultation with the manager;



- If the FirePro unit is still warm following activation, use heat-resistant gloves.

13.4 Waste and Environment

When the FirePro units have been activated they can be disposed of as normal waste following dismantling. When the FirePro units have not been activated and the extinguishing agent remains in them, they must be returned to the Distributor and/or its Dealers.

14 Safety Data Sheet – SDS

| | | |
|------------------------|--------------------------------|----------------|
| FIREPRO SYSTEMS LTD. | SAFETY DATA SHEET - SDS | FirePro |
| Issue date: 26/11/2018 | | |

| 1. Identification of the Substance/Company | |
|--|--|
| 1.1 | Trade Name FirePro |
| 1.2 | Manufacturer/Supplier |
| | FirePro Systems Ltd 8 Faleas Str., Agios Athanasios Industrial Area CY4101 Limassol CYPRUS |
| | Phone: + 357 25 379999 Fax: + 357 25 354432 |
| | Email: mail@firepro.com Website: www.firepro.com |
| 1.3 | Telephone number in case of emergency: +357 25 376146 |

| 2. Hazards Identification | |
|---|--|
| <ul style="list-style-type: none"> - Hazards for humans related to the FPC Solid Compound has not been found - Hazards for humans related to the aerosol released by the solid compound have not been established because TLV's are not applicable. <p>Signs and symptoms related to the aerosol phase are only referred to acute exposure and/or chronic overexposures, while in real life the exposure will be very short (i.e. in the event of an accidental discharge when people were not evacuated on time)</p> | |
| For humans | |
| Threshold Limit Values None established | |
| Signs and Symptoms by acute exposure | |
| Eye Contact At normal contact no injury | |
| Inhalation Not a likely route of entry | |
| Skin Contact At normal contact no injury | |
| Ingestion At normal contact no injury | |
| Chronic Overexposure At normal contact no injury | |
| Medical Conditions generally aggravated by Exposure None known | |
| The EU Classification and Hazard and Precautionary Statements as per CLP 1272/2008 referring to the components of the FPC Compound are related only to the single components considered as separate chemical entities. Once mixed in the production of the FPC Compound, the statements of the single components are not applicable being the FPC Compound a separate chemical entity. | |
| Product | |
| 2.1 | Potassium Nitrate |
| | EU Classification Oxidizer - |
| | Hazard Statements H270 Contact with combustible material may cause or intensify fire |
| | Precautionary Statements P210 Keep away from sources of ignition – No Smoking P370+P260 In case of fire and/or explosion, do not breathe fumes |
| Potassium Carbonate | EU Classification Irritant - |
| | Hazard Statements H302 Harmful if swallowed H320+H335+H315 Irritating to eyes, respiratory system and skin |
| | Precautionary Statements P305+P351+H338 In case of contact with eyes, rinse immediately with plenty of water and seek medical advice P282 Wear suitable gloves and eye/face protection |
| | EU Classification Flammable - |
| Magnesium | Hazard Statements H260 Contact with water liberates highly flammable gases H250 Spontaneously flammable in air. |

SAFETY DATA SHEET - SDS

Issue date: 26/11/2018

| | | | |
|---------------------|--------------------------|-----------|--|
| Magnesium | Precautionary Statements | P102 | Keep out of reach of children |
| | | P223 | In case of fire never use water |
| | | P402+P404 | Keep container tightly closed and dry |
| Epoxy Resin Polymer | EU Classification | Irritant | - |
| | Hazard Statements | H317 | May cause sensitization by skin contact |
| | | H413 | May cause long-term adverse effects in the aquatic environment |
| | Precautionary Statements | P302+P352 | In case of contact with skin , rinse with water |
| | | P282 | Wear suitable gloves and eye/face protection |
| | | P273 | Avoid release to the environment. Refer to special instructions/Safety Data Sheets |

| | | | | |
|-----------|---|-------------|----------------|---|
| 3. | Composition/Information on Ingredients | | | |
| | Component | Wt % | CAS No. | EINECS |
| 3.1 | Potassium Nitrate | 77 | 7757-79-1 | 231-818-8 |
| | Potassium Carbonate | 4 | 584-08-7 | 209-529-3 |
| | Magnesium | <1 | 7439-95-4 | 231-104-6 |
| | Epoxy Resin Polymer | 18 | 25068-38-6 | Any "polymerizate, polycondensate, or polyadduct" is exempted by 81/437/EEG |

| | | |
|-----------|---|---|
| 4. | First-Aid Measures | |
| | First-Aid measures are referred to accute exposure and/or chronic over exposure | |
| 4.1 | Inhalation | Remove from exposure area to fresh air. |
| | Eye Contact | If necessary wash eyes. |
| | Skin Contact | Change clothing and shoes. Wash skin with soap. |
| | Ingestion | Not likely. |

| | | |
|-----------|------------------------------------|--|
| 5. | Fire fighting Measures | |
| 5.1 | Extinguishing Media | This is an Extinguishing Agent |
| 5.2 | Unusual Fire and Explosion Hazards | The material does not present an explosion danger. It can be ignited by means of a fire. Hot aerosol is present in the close up area of the outlets. |
| 5.3 | Special Procedures | In places where there is a fire always wear personal protecting equipment and clothing |

| | | |
|-----------|------------------------------------|------------------------------|
| 6. | Accidental Release Measures | |
| | Personal Precautions | |
| 6.1 | Respiratory Protection | at normal contact not needed |
| | Hand Protection | at normal contact not needed |
| | Eye Protection | at normal contact not needed |
| | Skin and Body Protection | at normal contact not needed |
| 6.2 | Environmental Precautions | |
| | Waste Disposal Methods | See section 13 |
| 6.3 | Clean up Precautions | Sweep up |

| | | |
|-----------|-----------------------------|---|
| 7. | Handling and Storage | |
| 7.1 | Handling Precautions | Avoid contact with combustible materials |
| 7.2 | Storage Precautions | Should be stored in original container. Keep dry. |
| | Storage Class | 9 Miscellaneous , solid |

| 8. Exposure Controls and Personal Protection | | |
|--|--|------------------------------|
| 8.1 | Exposure Before entering a room with the material in aerosol phase vent properly to avoid unnecessary exposure. | |
| 8.2 | Personal Protection | |
| | Respiratory Protection | at normal contact not needed |
| | Hand Protection | at normal contact not needed |
| | Eye Protection | at normal contact not needed |
| | Skin and Body Protection | at normal contact not needed |

| 9. Physical and Chemical Characteristics | | |
|--|--|----------------|
| | Appearance | Solid |
| | Colour | Off white |
| | Odour | None |
| | Relative Density | Not applicable |
| | Solubility in water | Insoluble |
| | Ph (if in water, % Conc.) | Not determined |
| | Boiling Point | Not applicable |
| | Vapour Pressure (mm Hg) | Not applicable |
| | Vapour Density | Not applicable |
| | Flash Point | Not applicable |
| | Flammability Limits in Air (% by Volume) | Not applicable |
| | Auto Flammability | Not applicable |
| | Explosive Properties | Not applicable |
| | Oxidizing Properties | Not determined |

| 10. Stability and Reactivity | | |
|------------------------------|-----------------------------------|-------------------|
| 10.1 | Stability | :Stable |
| | Conditions to avoid | :None Known |
| 10.2 | Hazardous Reactions | :Will not occur |
| | Conditions to avoid | :None known |
| 10.3 | Materials to avoid | :None known |
| 10.4 | Hazardous Decompositions Products | :None ascertained |

| 11. Toxicological Information | | | |
|-------------------------------|--|---|--|
| | The TLV's (Threshold Limit Values) of the chemicals released in the aerosol phase are applicable only in case of long , as long as a complete professional life, exposure. This is not the case of a real life situation. | | |
| 11.1 | Product The potential damage is not caused by the product mixture composition, but by the fact that it is respirable. The TLV's apply in case of long exposure , sometimes exposure during a complete professional life , whilst in this case is once only and short (in case of accidental discharge when evacuation does not take place on time) In case of fire the toxicity is caused by the fire itself and the products involved in the fire | | |
| 11.2 | Components | | |
| | Potassium Nitrate | Toxicity | Oral LD ₅₀ (rat) 3750 mg/Kg |
| | | Target Organs | Blood, central nervous system |
| | Potassium Carbonate | Toxicity | Oral LD ₅₀ (rat) 1870 mg/Kg Oral LD ₅₀ (mouse) 2570 mg/Kg |
| | | Target Organs | Respiratory system |
| | Magnesium | Toxicity | Oral LD ₅₀ (dog) 230 mg/Kg |
| | | Target Organs | Central nervous system, liver, kidneys |
| Epoxy Resin Polymer | Toxicity | Oral LD ₅₀ (rat) 11.4 g/Kg | |
| | Irritation Data | Skin (guinea pig) 2750 mg/55 days Inert Eye (rabbit) 100 mg Mild | |

| | | |
|------|---|---------------------------------|
| 12. | Ecological Information | |
| 12.1 | Mobility | as per available data no effect |
| | Absorption/Desorption | as per available data no effect |
| 12.2 | Degradability | as per available data no effect |
| | Biotic and Abiotic Degradation | as per available data no effect |
| | Aerobic and Anaerobic Degradation | as per available data no effect |
| | Persistence | as per available data no effect |
| 12.3 | Accumulation | as per available data no effect |
| | Bioaccumulation Potential | as per available data no effect |
| | Biomagnification | as per available data no effect |
| 12.4 | Short and Long Term Effects on | |
| | Ecotoxicity | as per available data no effect |
| | Aquatic Organisms | as per available data no effect |
| | Soil Organisms | as per available data no effect |
| | Plants and Terrestrial animals | as per available data no effect |
| 12.5 | Other Adverse Effects | |
| | Ozone Depleting Potential (ODP) | none |
| | Photochemical Ozone Creation Potential | none |
| | Global Warming Potential (GWP) | none |
| | Effects on Waste Water Treatment Plants | as per available data no effect |

| | |
|------|---|
| 13. | Disposal Considerations |
| 13.1 | Dispose of in Compliance with local, state and national regulations |

| | | | |
|---|--|---|----------------|
| 14. | Transport Information | | |
| 14.1 | Air Transport (ICAO-IATA / DGR) | | |
| | UN Number | 3335 | |
| | UN proper shipping name | Aviation regulated solid,n.o.s.* (contains potassium nitrate) | |
| | Transport Hazard class | ICAO / IATA Class | 9 |
| | | ICAO / IATA Subrisk | Not Applicable |
| | Environmental hazard | Not Applicable | |
| | Special Precautions for user | Cargo Only Packing Instructions | 956 |
| | | Cargo Only Maximum Qty/Pack | 400 kg |
| | | Passengers and Cargo Packing Instructions | 956 |
| | | Passenger and Cargo Maximum Qty / Pack | 400 kg |
| Passenger and Cargo Limited Quantity Packing Instructions | | Y956 | |
| Passenger and Cargo Limited Maximum Qty / Pack | | 30 kg G | |

| | | | | |
|--------------------|------------------------------------|--|--------------------------|--|
| 14.2 | Sea Transport (IMDG – Code) | | | |
| | UN Number | Not Applicable | | |
| | Packing Group | Not Applicable | | |
| | UN proper shipping name | Not Applicable | | |
| | Environmental hazard | Not Applicable | | |
| | Transport hazard (classes) | IMDG Class | Not Applicable | |
| | | IMDG Subrisk | Not Applicable | |
| | Special precautions for user | EMS Number | Not Applicable | |
| Special provisions | | 960 (Not Subject to the provisions of this Code but may be subject to provisions governing the transport of dangerous goods by other modes). | | |
| Limited Quantities | | Not Applicable | | |
| 14.3 | Land transport (ADR) | | | |
| | UN Number | Not Applicable | | |
| | Packing Group | Not Applicable | | |
| | UN proper shipping name | Not Applicable | | |
| | Environmental hazard | Not Applicable | | |
| | Transport hazard class(es) | Class | Not Applicable | |
| | | Subrisk | Not Applicable | |
| | Special precautions for user | Special provisions | 106 (Not Subject to ADR) | |
| Limited quantity | | Not Applicable | | |

| | | |
|-----|-----------------------------------|--|
| 15. | Regulatory Information | |
| | Limit Values for exposure | None listed |
| | EINECS Status | All components are included in EINECS inventories |
| | Restrictions on Marketing and Use | None (Refer to any other national measures that may be relevant) |

| | | |
|------|--------------------------|--|
| 16. | Other Information | |
| 16.1 | None Known | |

Disclaimer

The data in the above safety data sheet reflect the current state of knowledge of our product and shall be used only as a guideline. No binding statements as to the contractually agreed product characteristics may be inferred there from.

15 Alphabetical Technical Glossary

This information, instruction and user manual contains technical terms, the most important of which appear in the list below in alphabetical order with a brief explanation. The “page” column gives the page on which the term is used for the first time.

| | TERM | EXPLANATION | PAGE | |
|----------------------|-------------------------|--|---|----|
| A | activator | Part that puts the unit into operation | 18 | |
| | Activation | the putting of extinguishing unit and/or installation into operation | 17 | |
| | Aero | air | 6 | |
| | Aerosol | small particle in homogeneous diffusion in the air | 5 | |
| | ATEX directive | consists of two EU directives describing what equipment and work space is allowed in an environment with an explosive atmosphere | 17 | |
| | B | BMC | fire detection and fire alarm control unit/control system | 51 |
| building decree | | legislation concerning building engineering aspects for buildings | 49 | |
| building regulations | | regulations concerning building engineering aspects for buildings | 36 | |
| C | | Cable monitoring | system that monitors the functionality of power cables | 56 |
| | cm | centimetres (size indication) | 51 | |
| | colloids | small particles that are suspended in another substance or gas | 6 | |
| | compartment | enclosed space with fixed dimensions in which extinguishing must take place | 36 | |
| | component | part of extinguishing unit and/or installation to be used | 2 | |
| | control switch | button for effecting manual extinguishing | 51 | |
| | control system | system that puts (an)other system(s) into operation following activation | 36 | |
| | core fires | fires within solid substances | 17 | |
| | D | detector siting | location of fire detector connected to the fire detection and fire alarm control unit | 49 |
| | | DIN | German national organization for Standardization | 55 |
| discharge duration | | duration of discharge of extinguishing agent | 37 | |
| discharge length | | length between extinguisher and achievable distance of the discharging extinguishing agent | 21 | |
| discharge opening | | opening through which the extinguishing agent discharges | 36 | |
| discharge temp. | | temperature of the discharging extinguishing agent | 36 | |
| Dispersion | | The distribution of a substance | 6 | |
| Detection | | The detection of preset values | 3 | |
| Detection system | | System for detecting fires | 17 | |
| Detectors | | Part of the detection system | 42 | |
| E | | electrical impulse | current by which the activator puts the extinguisher into operation | 42 |
| | | element | part of extinguishing unit | 19 |
| | | EMC directive | Electromagnetic Compatibility Directive | 2 |
| | emergency power supply | supply that temporarily takes over the function in the event of power failure | 42 | |
| | evacuation installation | computer-controlled system that provides for visual/acoustic signal | 49 | |
| | exothermic | reaction in which heat is released | 44 | |
| | extinguishing system | system for limiting and/or extinguishing fires | 5 | |

| | | | |
|---|--|---|----|
| F | fire class | subdivision of flammable substances and extinguishing agent to be used | 13 |
| | fire detection and fire alarm control unit | computer that converts detection into an alarm | 51 |
| | fire brigade panel | panel on which the fire brigade can see where the fire alarm is located | 51 |
| | formula | succession of the calculation steps to be taken | 34 |
| | FP | abbreviation for FirePro brand name | 20 |
| | FPC | FirePro Compound is the denomination of the solid extinguishing chemical compound in the extinguisher | 19 |
| | G | | |
| H | heat absorbing | part of extinguisher in which the heat that has developed is absorbed | 19 |
| | hydrocarbons | substances distilled from oil | 17 |
| I | installation attestation | written declaration of functionality from the fire detection company | 58 |
| | installation certificate | certificate that is issued following inspection and approval of installation | 53 |
| J | | | |
| K | K ₂ CO ₃ | chemical abbreviation of Potassium Carbonate | 63 |
| | KOH | chemical abbreviation of Potassium Hydroxide | 6 |
| L | Leakage losses | Amount of extinguishing agent that can flow away through openings | 36 |
| | Logbook | Handbook for day-to-day manager and installer of the installation | 58 |
| M | m | Metres (size indication) | 6 |
| | m ³ | cubic metres (size indication) | 63 |
| | manuals units | type of extinguisher that are activated by hand | 48 |
| | micrometre | unit indication for particle size | 6 |
| | mm | millimetres (size indication) | 21 |
| | model | properties laid down in clear designation | 19 |
| | SDS | Safety Data Sheet | 65 |
| N | Nanometres | Unit indication for particle size | 6 |
| | NEN | Netherland's national organization for Standardization | 3 |
| | nominal | weighed amount of extinguishing agent for discharge | 34 |
| O | Operating temperature | Temperature at which a reaction will occur | 45 |
| P | potassium | chemical element | 6 |
| | Performance requirement | requirements that an installation must meet | 13 |
| Q | | | |
| R | Residue | substance that remains following an activation | 63 |
| S | Safety factor | Multiplier of the extinguishing density to determine the design application density | 34 |
| | Schedule of requirements | Schedule of requirements that is drawn up for the installation in advance | 13 |
| | self-activation temperature | temperature at which the unit puts itself into operation | 38 |
| | short circuit | unwanted flow of current that disturbs proper operation | 56 |
| | siting | determination of location and amount of extinguishing agent by survey | 36 |
| | Slow whoop | visual and acoustic signal emitter for alarm | 51 |
| | sol | colloidal solution | 6 |

| | | | |
|---|------------------------|---|----|
| T | thermodifferential | detectors that react to heat differences in the event of fire | 50 |
| | thermomaximal | detectors that react to set temperature in the event of fire | 50 |
| | transmission | message from control unit via network to an alarm post (e. g. fire brigade) | 13 |
| U | unit | collective term for extinguisher in which all the elements are present | 18 |
| V | | | |
| W | WBDBO | abbreviation factor time for remaining intact of wall parts and/or walls (Wall-Fire-Penetration-Fire-Flashover) | 36 |
| | Working Conditions Act | Dutch health and safety at work legislation | 18 |
| X | | | |
| Y | | | |
| Z | | | |

FirePro

Appendix 1

FirePro Aerosol Generators Installation Drawings

To be read and used in conjunction with
FirePro Information, Instruction & User
Manual Version 8, May 2020

FirePro Systems Ltd

8 Faleas Str., CY-4101 Limassol, CYPRUS
Tel. +357 25 379999, Fax. +357 25 354432
Web: www.firepro.com, email: mail@firepro.com
An ISO 9001:2015 & ISO 14001:2015 registered company

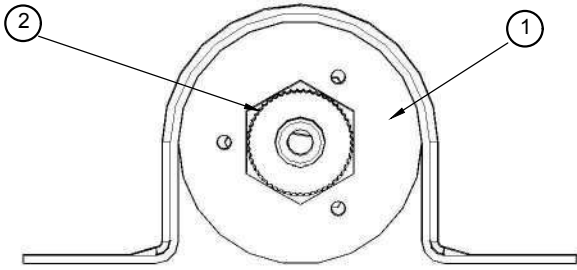

Top View

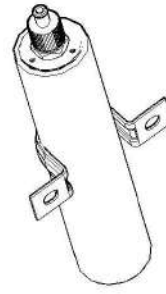

Iso View (Top)

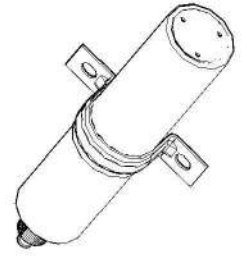

Iso View (Bottom)

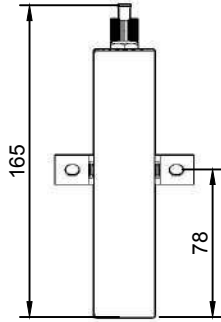

Front View

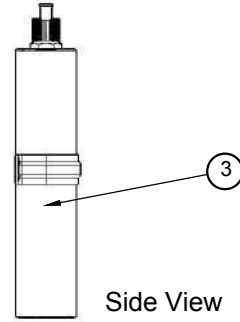

Side View

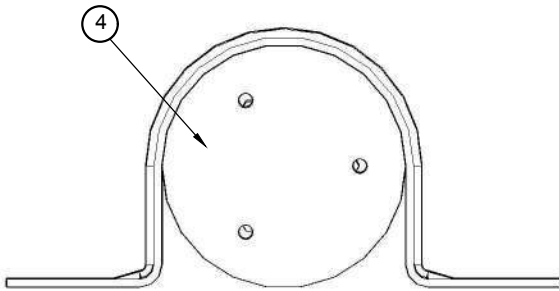

Bottom View

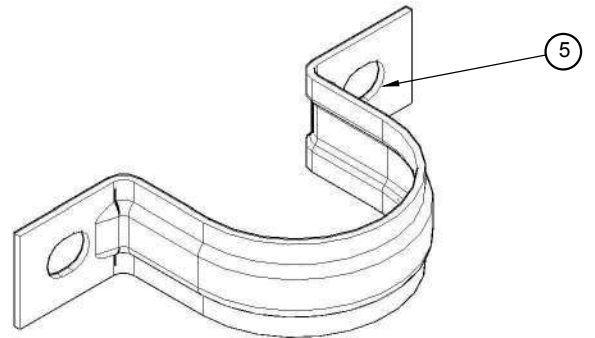

Isometric View of Bracket

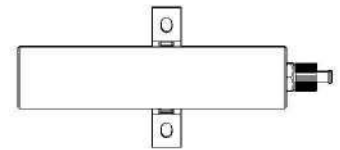
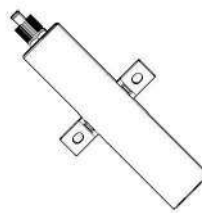
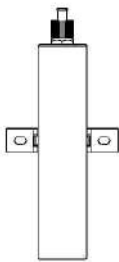

Installation Options

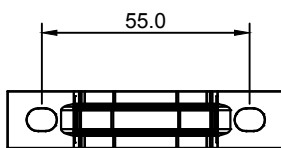

Fixing Drills

| | | | |
|---|---|---------------------------|-----------|
| 5 | 1 | BRACKET | C20BR |
| 4 | 1 | BOTTOM OUTLET COVER PLATE | C20BOCS |
| 3 | 1 | HOUSING TUBE | C20HTS |
| 2 | 1 | THERMOCONNECTOR | C1-2-5THC |
| 1 | 1 | TOP OUTLET COVER PLATE | C20TOCS |

| Position | Quantity | Denomination | Type / DWG. Number |
|----------|----------|--------------|--------------------|
|----------|----------|--------------|--------------------|

PART LIST

FirePro. FirePro Systems Ltd
Condensed aerosol generator

ISE
L.E. MARSA LAZARUS
19/04/2007
0703

DRAWING NUMBER: ID-20SE
DATE: 15/04/10

TITLE:
INSTALLATION DRAWING

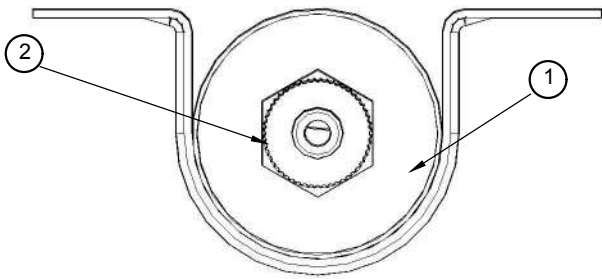

Top View

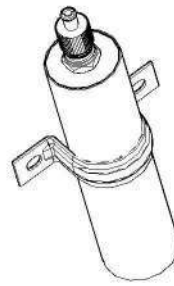

Iso View (Top)

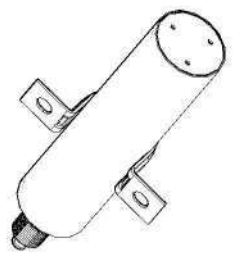

Iso View (Bottom)

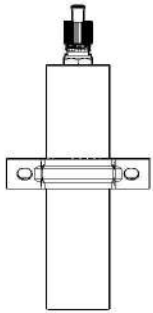

Front View

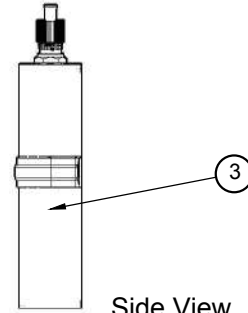

Side View

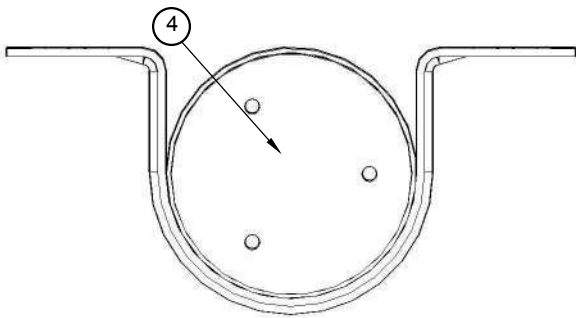

Bottom View

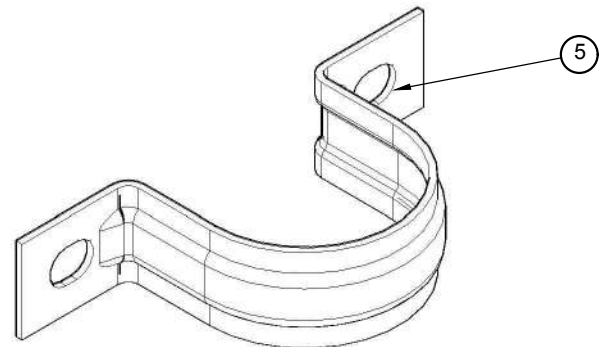

Isometric View of Bracket

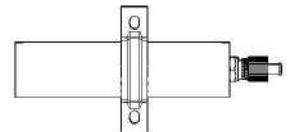
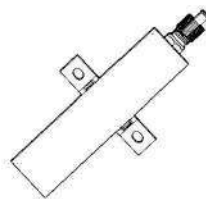
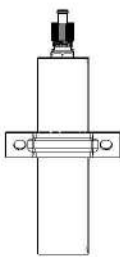

Installation Options

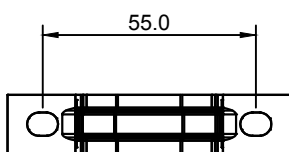

Fixing Drills

| | | | |
|------------------|----------|---------------------------|--------------------|
| 5 | 1 | BRACKET | C20BR |
| 4 | 1 | BOTTOM OUTLET COVER PLATE | C20BOCS |
| 3 | 1 | HOUSING TUBE | C20THT |
| 2 | 1 | BTA BLISTER ASSEMBLY | BTABLASS |
| 1 | 1 | TOP COVER PLATE | C2TTCP |
| Position | Quantity | Denomination | Type / DWG. Number |
| PART LIST | | | |

FirePro Systems Ltd
FirePro. Condensed aerosol genera  **20T**

DRAWING NUMBER: ID-20T
 DATE: 02/10/14

TITLE:
 INSTALLATION DRAWING

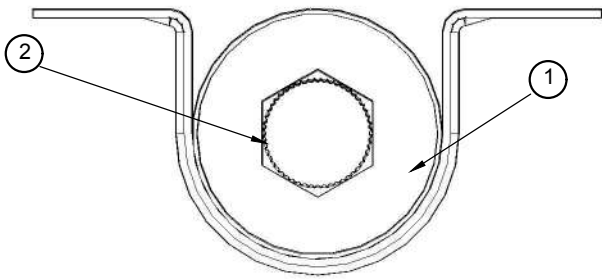

Top View

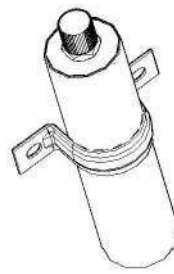

Iso View (Top)

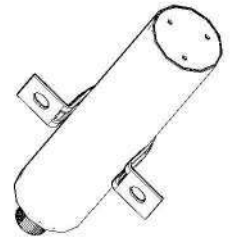

Iso View (Bottom)

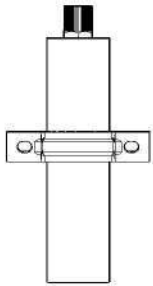

Front View

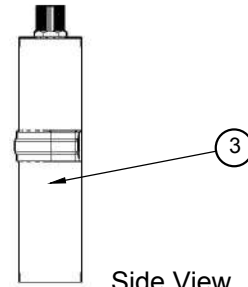

Side View

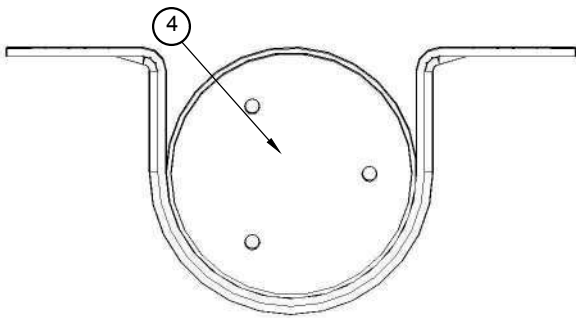

Bottom View

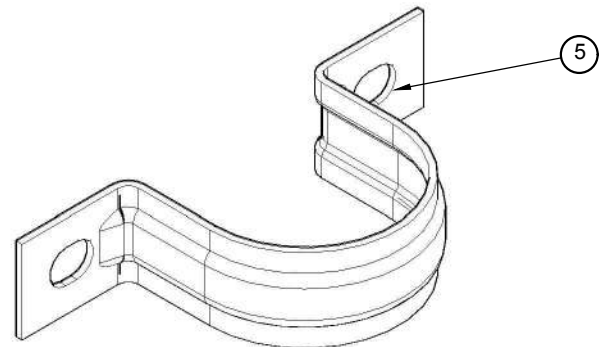

Isometric View of Bracket

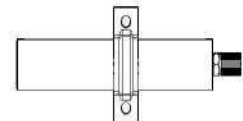
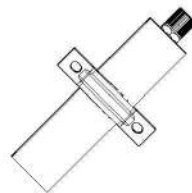
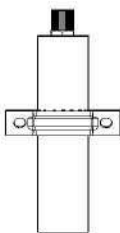

Installation Options

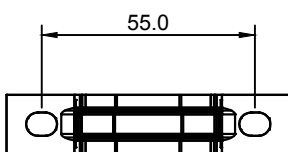

Fixing Drills

| | | | |
|------------------|----------|---------------------------|--------------------|
| 5 | 1 | BRACKET | C20BR |
| 4 | 1 | BOTTOM OUTLET COVER PLATE | C20BOCS |
| 3 | 1 | HOUSING TUBE | C20THT |
| 2 | 1 | BTA BLISTER ASSEMBLY | BTABLASS |
| 1 | 1 | TOP COVER PLATE | C2TTCP |
| Position | Quantity | Denomination | Type / DWG. Number |
| PART LIST | | | |

FirePro Systems Ltd
FirePro. Condensed aerosol genera  **0TH**

DRAWING NUMBER: ID-20TH
 DATE: 02/10/14

TITLE:
 INSTALLATION DRAWING

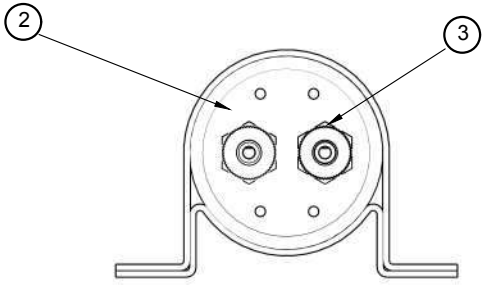

Top View

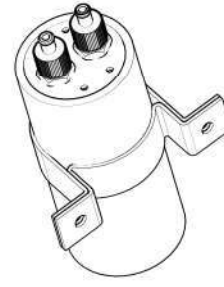

Iso View (Top)

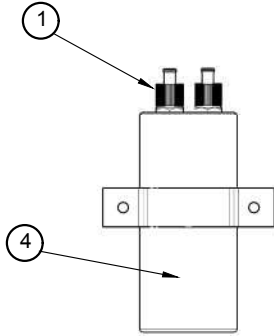

Front View

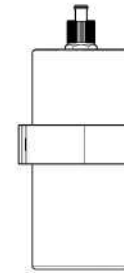

Side View

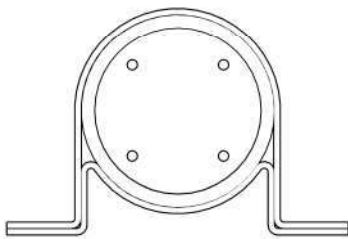

Bottom View

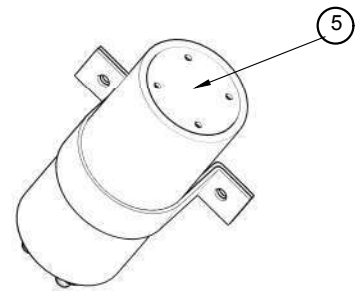

Iso View (Bottom)

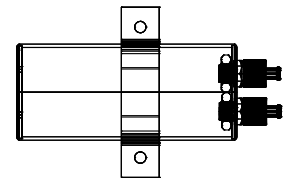
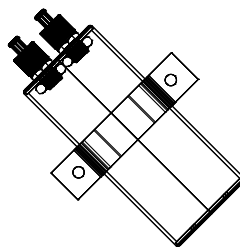
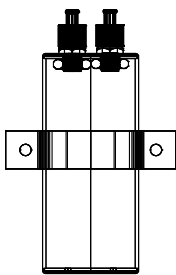

Installation Options

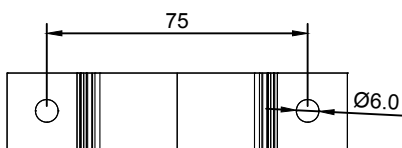

Fixing Drills

| | | | |
|------------------|----------|---------------------------|--------------------|
| 5 | 1 | BOTTOM OUTLET COVER PLATE | C40BOCPS |
| 4 | 1 | HOUSING TUBE | C40HTS |
| 3 | 2 | THERMOCONNECTOR NUT | |
| 2 | 1 | TOP OUTLET COVER PLATE | C40TOCPS |
| 1 | 2 | THERMOCONNECTOR | C1-2-5THC |
| Position | Quantity | Denomination | Type / DWG. Number |
| PART LIST | | | |

FirePro. FirePro Systems Ltd
Condensed aerosol generator

DRAWING NUMBER: ID-40S
DATE: 15/04/10

TITLE:
INSTALLATION DRAWING

FirePro S
L.E. MARCA LAUREA MERCE
1990-2000
0703

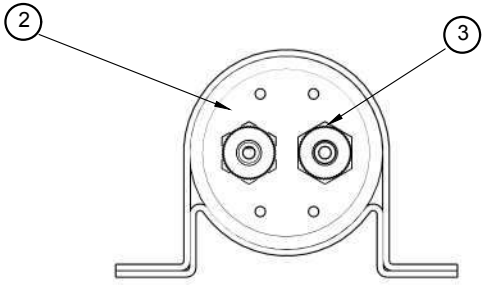

Top View

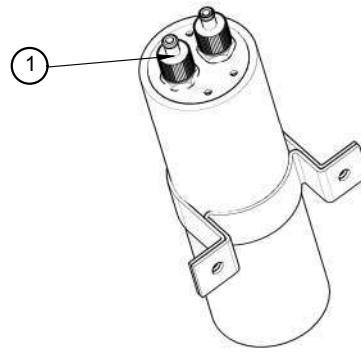

Iso View (Top)

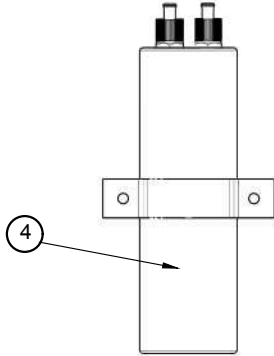

Front View

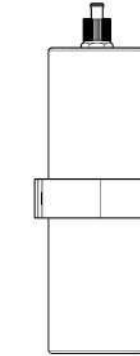

Side View

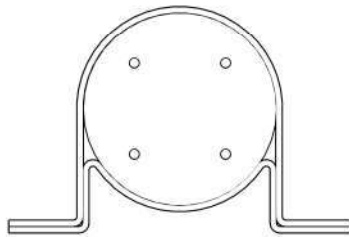

Bottom View

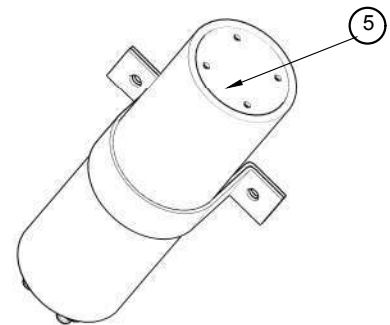

Iso View (Bottom)

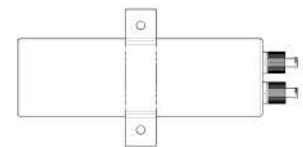
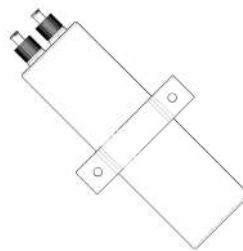
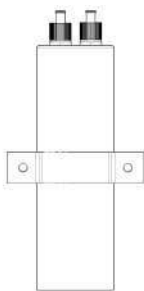

Installation Options

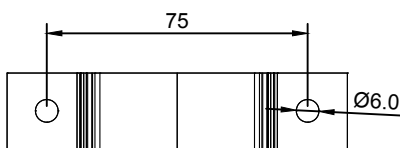

Fixing Drills

| | | | |
|------------------|----------|---------------------------|--------------------|
| 5 | 1 | BOTTOM OUTLET COVER PLATE | C80BOCPS |
| 4 | 1 | HOUSING TUBE | C80HTS |
| 3 | 2 | THERMOCONNECTOR NUT | |
| 2 | 1 | TOP OUTLET COVER PLATE | C80TOCPS |
| 1 | 2 | THERMOCONNECTOR | C1-2-5THC |
| Position | Quantity | Denomination | Type / DWG. Number |
| PART LIST | | | |

FirePro. FirePro Systems Ltd
Condensed aerosol generator

DRAWING NUMBER: ID-80S
DATE: 15/04/10

TITLE:
INSTALLATION DRAWING

FirePro S
L.E. MARCA LAUREA MERCATO
1990-2000
0705

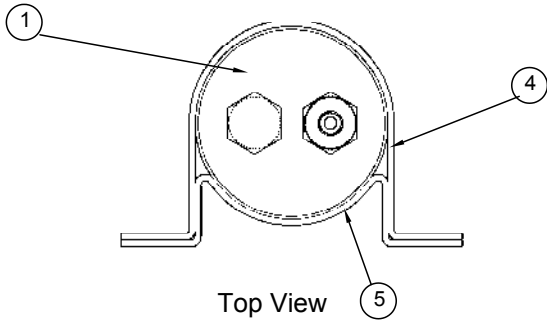

Top View

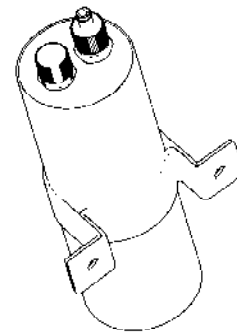

Iso View (Top)

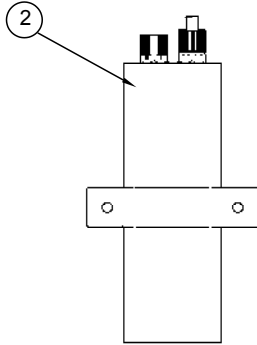

Front View

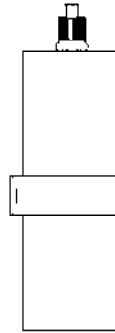

Side View

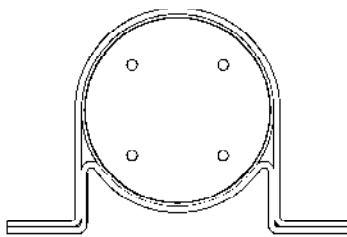

Bottom View

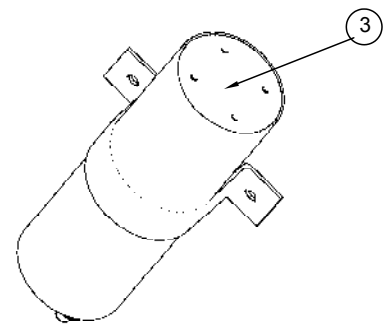

Iso View (Bottom)



Installation Options

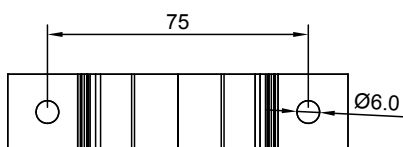

Fixing Drills

| | | | |
|----------|----------|--------------------|-----------------------|
| 5 | 1 | BRACKET PART2 | C4080BRS2 |
| 4 | 1 | BRACKET PART1 | C4080BRS1 |
| 3 | 1 | BOTTOM COVER PLATE | C40TBCPS C80TBCPS |
| 2 | 1 | HOUSING TUBE | C40THT C80THT |
| 1 | 1 | TOP COVER ASSEMBLY | C48TTCASS |
| Position | Quantity | Denomination | Type / DWG. Number |

PART LIST

FirePro [®] **FirePro Systems Ltd** Condensed aerosol generator **FP-40T**
 **0T**

DRAWING NUMBER: ID-40T,80T
 DATE: 02/10/14

TITLE:
 INSTALLATION DRAWING (Option 1)

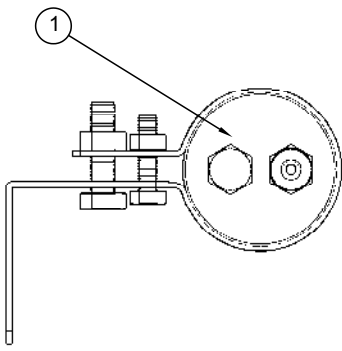

Top View

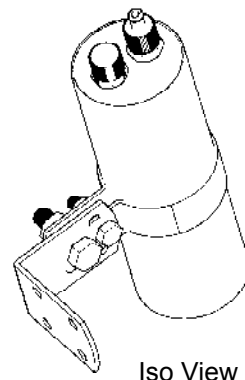

Iso View (Top)

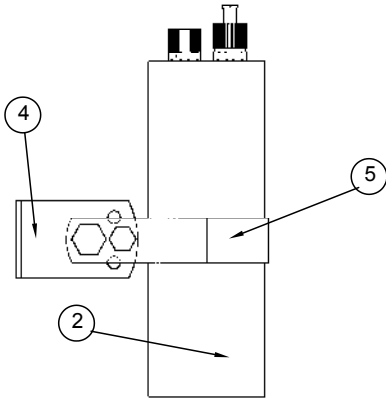

Front View

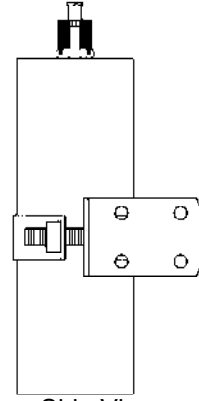

Side View

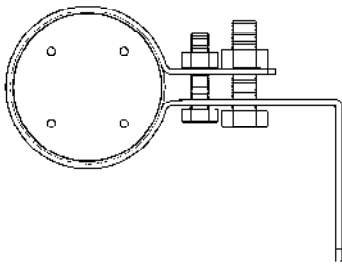

Bottom View

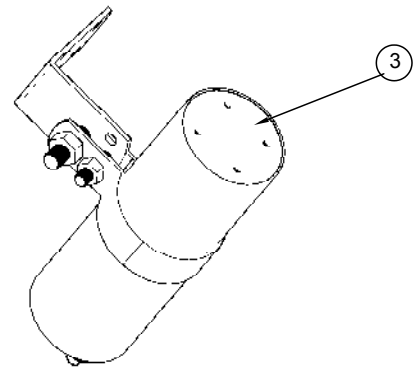

Iso View (Bottom)

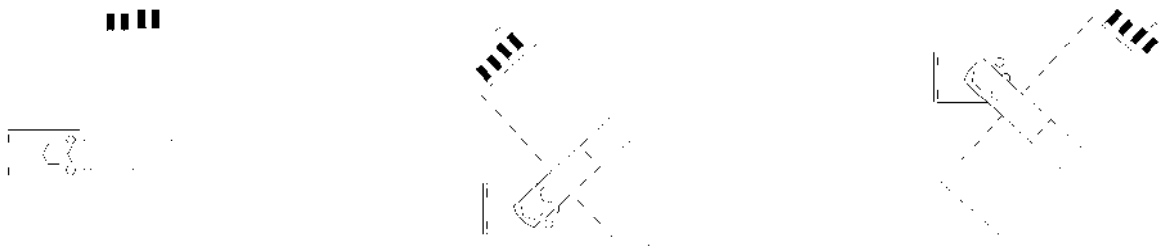

Installation Options

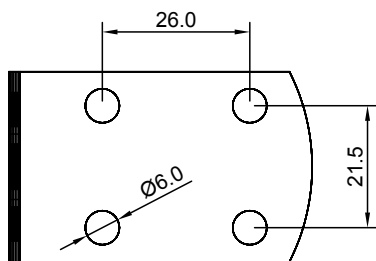

Fixing Drills

| | | | |
|------------------|----------|-----------------------|-----------------------|
| 5 | 1 | ROUND BRACKET "A" | C4-8RBR |
| 4 | 1 | ANGLE BRACKET SUPPORT | C1-2-5ABS |
| 3 | 1 | BOTTOM COVER PLATE | C40TBCPS C80TBCPS |
| 2 | 1 | HOUSING TUBE | C40THT C80THT |
| 1 | 1 | TOP COVER ASSEMBLY | C48TTCASS |
| Position | Quantity | Denomination | Type / DWG. Number |
| PART LIST | | | |

FirePro® **FirePro Systems Ltd** Condensed aerosol generator **FP-40T**
0T

DRAWING NUMBER: ID-40T,80T
DATE: 02/10/14

TITLE: INSTALLATION DRAWING (Option 2)

[Signature]
L. MARRA / A. MARINO
14/10/2014
010

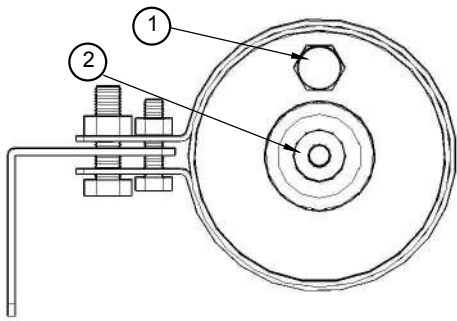

Top View

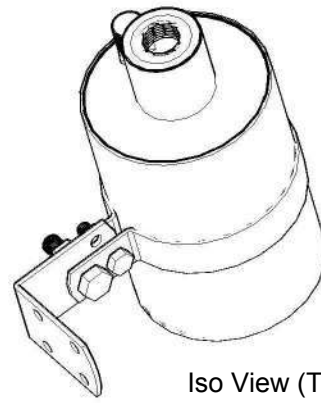

Iso View (Top)

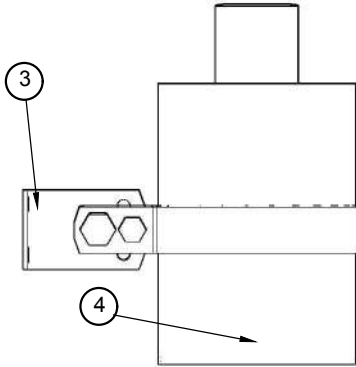

Front View

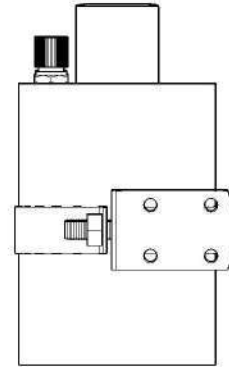

Side View

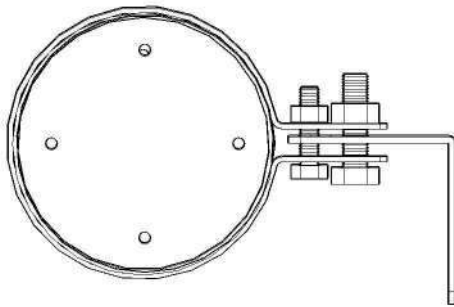

Bottom View

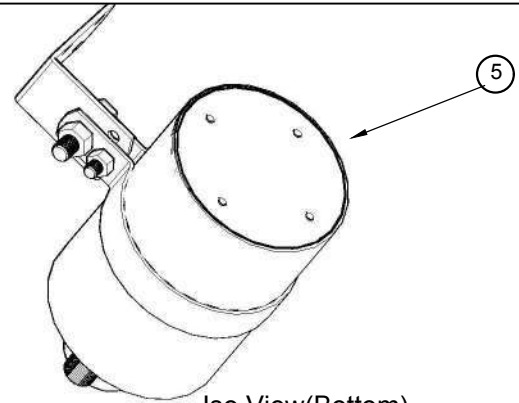

Iso View (Bottom)

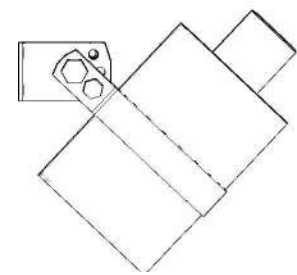
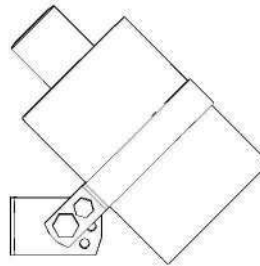
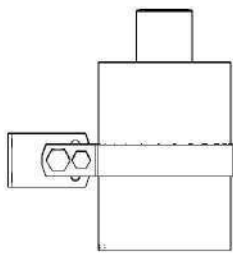

Installation Options

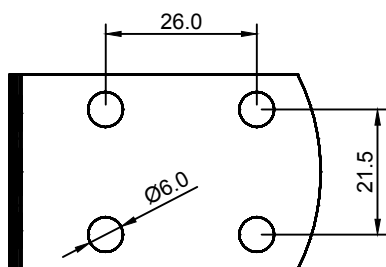

Fixing Drills

| 5 | 1 | HOUSING EXIT COVER | C1HEC |
|------------------|----------|-----------------------|--------------------|
| 4 | 1 | HOUSING TUBE | C1HT |
| 3 | 1 | ANGLE BRACKET SUPPORT | C1-2-5ABS |
| 2 | 1 | IGNITER | C1-2-5IGN |
| 1 | 1 | BTA BLISTER PART 2 | BTABLP2 |
| Position | Quantity | Denomination | Type / DWG. Number |
| PART LIST | | | |

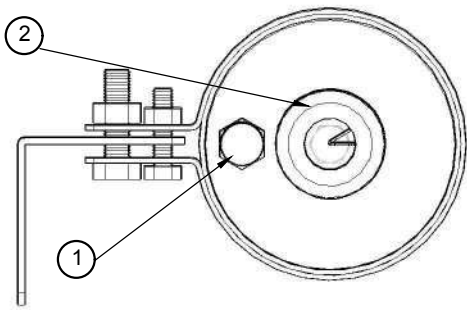

Top View

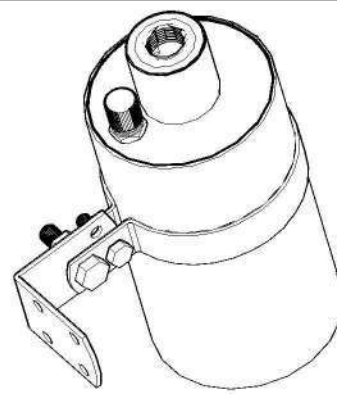

Iso View (Top)

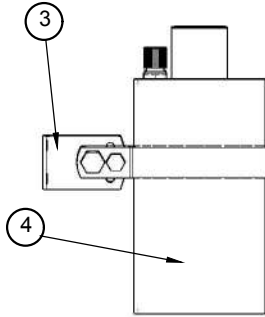

Front View

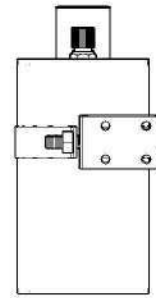

Side View

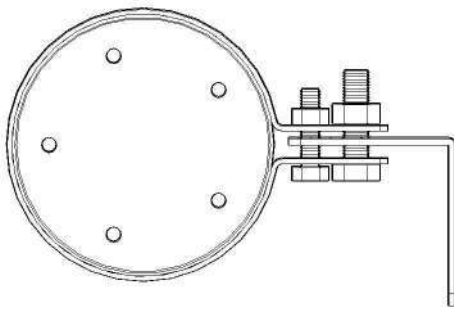

Bottom View

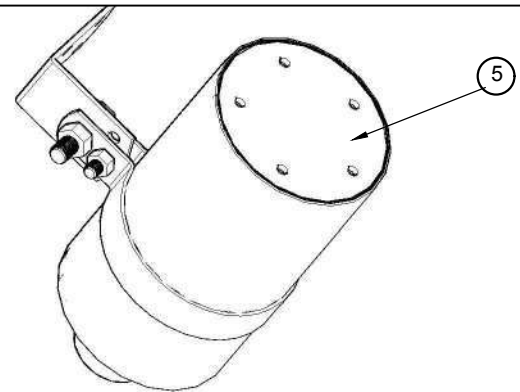

Iso View (Bottom)

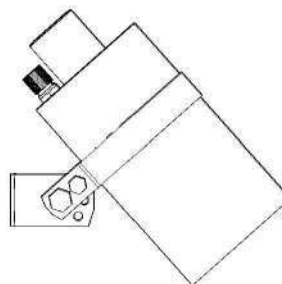
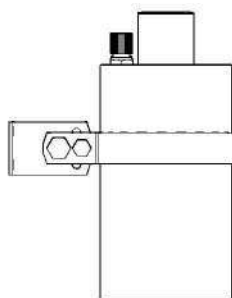

Installation Options

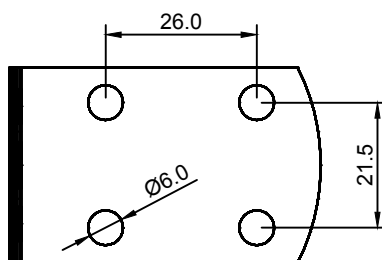

Fixing Drills

| | | | |
|------------------|----------|-----------------------|--------------------|
| 5 | 1 | HOUSING EXIT COVER | C2HEC |
| 4 | 1 | HOUSING TUBE | C2HT |
| 3 | 1 | ANGLE BRACKET SUPPORT | C1-2-5ABS |
| 2 | 1 | IGNITER | C1-2-5IGN |
| 1 | 1 | BTA BLISTER PART 2 | BTABLP2 |
| Position | Quantity | Denomination | Type / DWG. Number |
| PART LIST | | | |

FirePro. FirePro Systems Ltd Condensed aerosol genera  '00S
LE. MARKA LAUREA MURCET 1990-2000 0703

DRAWING NUMBER: ID-200S
 DATE: 05/01/16

TITLE:
 INSTALLATION DRAWING

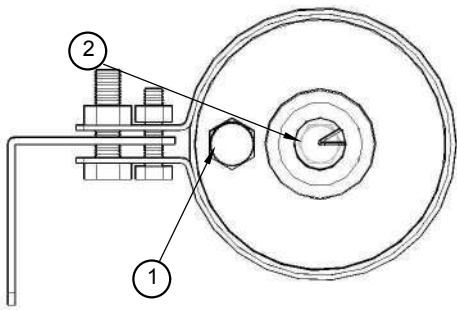

Top View

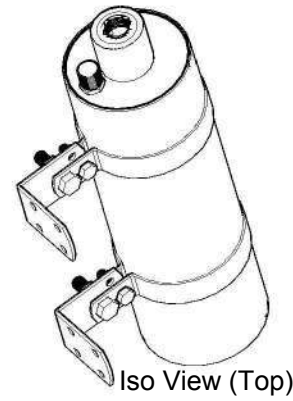

Iso View (Top)

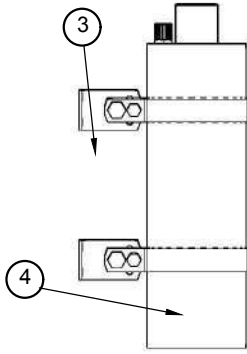

Front View

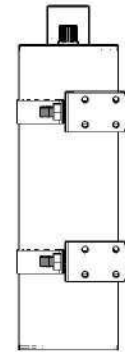

Side View

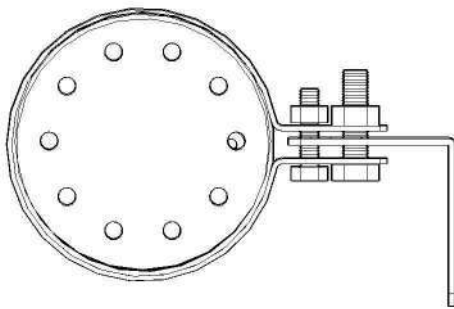

Bottom View

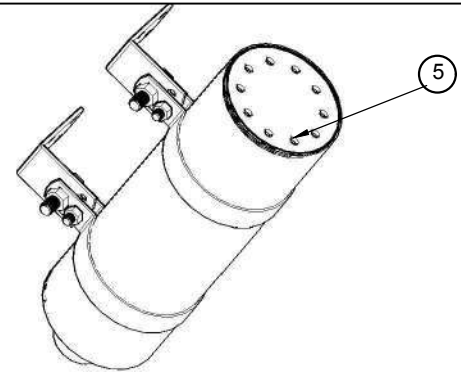

Iso View (Bottom)

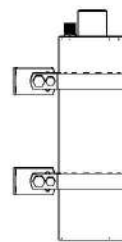

Installation Options

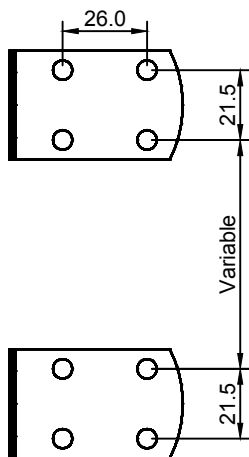

Fixing Drills

| | | | |
|------------------|----------|-----------------------|--------------------|
| 5 | 1 | HOUSING EXIT COVER | C5HEC |
| 4 | 1 | HOUSING TUBE | C5HT |
| 3 | 1 | ANGLE BRACKET SUPPORT | C1-2-5ABS |
| 2 | 1 | IGNITER | C1-2-5IGN |
| 1 | 1 | BTA BLISTER PART 2 | BTABLP2 |
| Position | Quantity | Denomination | Type / DWG. Number |
| PART LIST | | | |

FirePro. FirePro Systems Ltd
Condensed aerosol genera  00S

DRAWING NUMBER: ID-500S
DATE: 05/01/16

TITLE:
INSTALLATION DRAWING

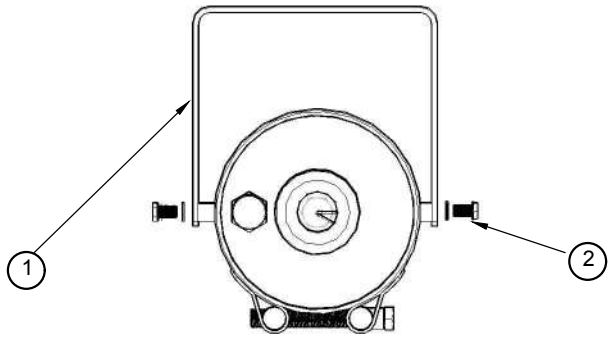

Top View

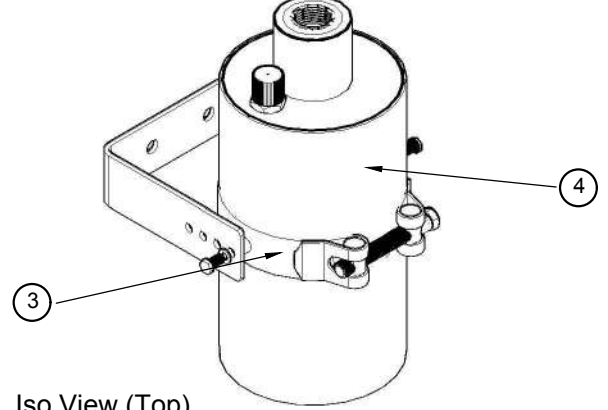

Iso View (Top)

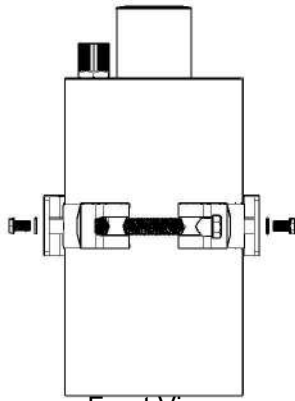

Front View

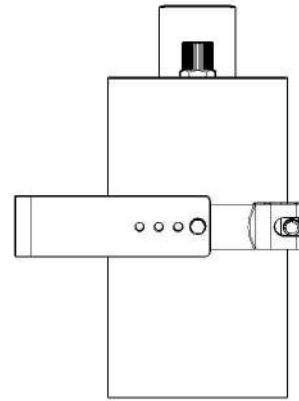

Side View

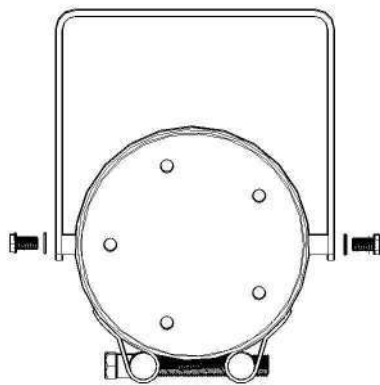

Bottom View

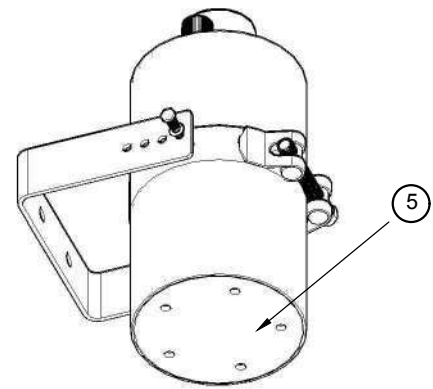

Iso View (Bottom)

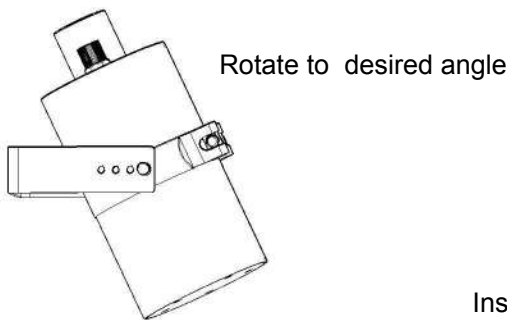

Rotate to desired angle

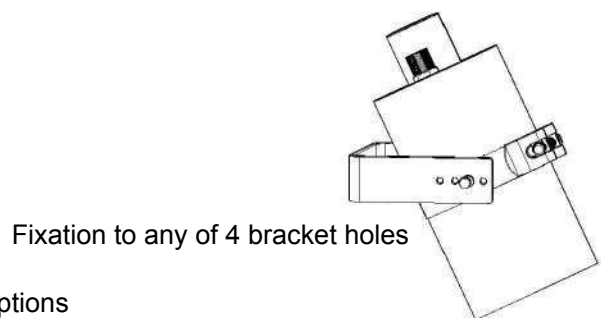

Fixation to any of 4 bracket holes

Installation Options

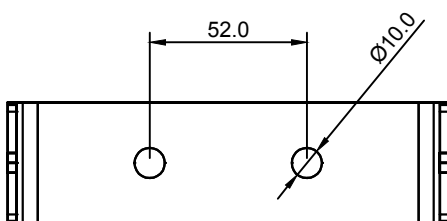

Fixing Drills

| | | | |
|------------------|----------|----------------------------|--------------------|
| 5 | 1 | AEROSOL OUTLET | |
| 4 | 1 | GENERATOR | |
| 3 | 1 | ROUND BRACKET WITH M8 BOLT | C1-2-5RB |
| 2 | 1 | M5x0.8 BOLT WITH WASHER | C1-2-5BW |
| 1 | 1 | U-BRACKET | C1-2-5U |
| Position | Quantity | Denomination | Type / DWG. Number |
| PART LIST | | | |

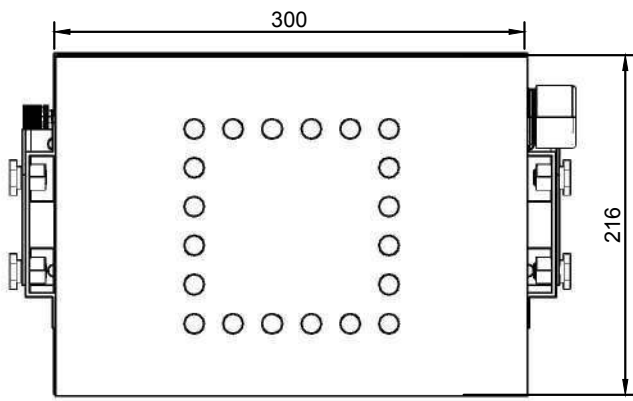

Bottom View

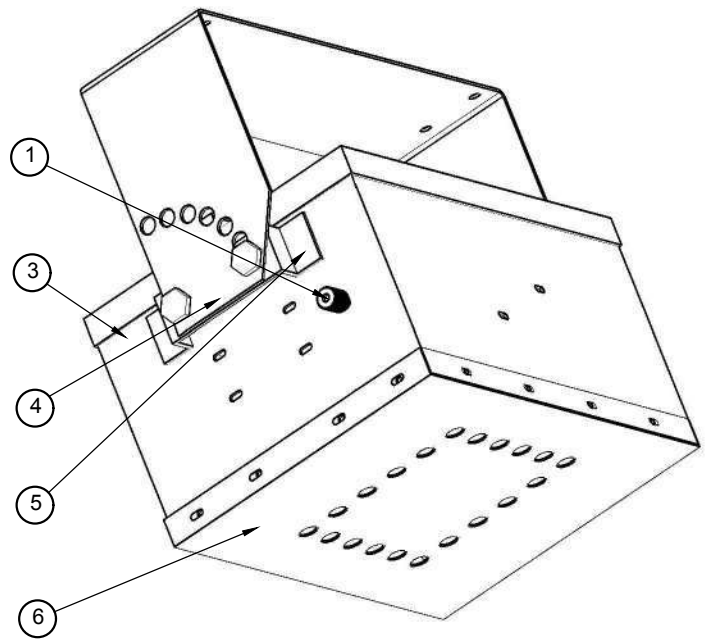

Iso View(Bottom)

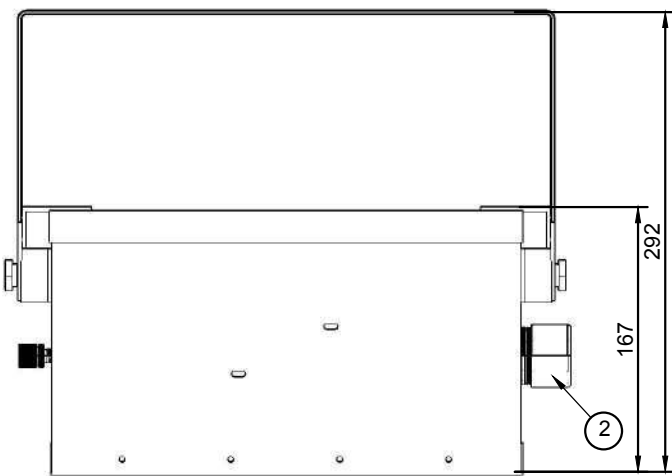

Front View

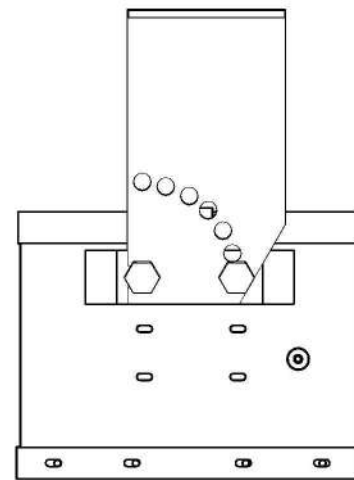

Side View

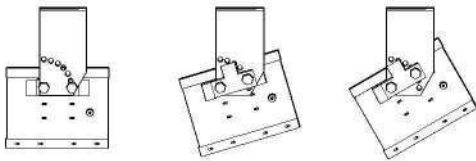

CEILING

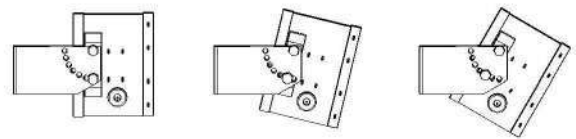

WALL

Installation Options

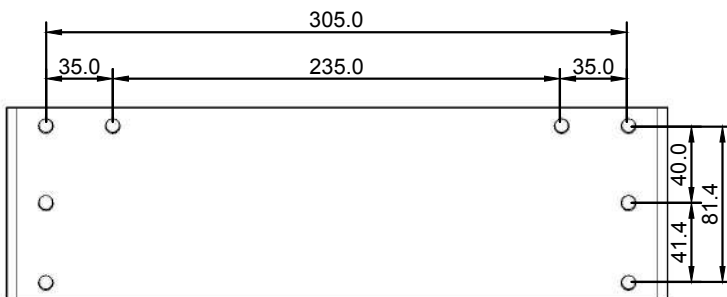

Fixing Drills

| | | | |
|------------------|----------|----------------------------------|--------------------|
| 6 | 1 | OUTLET | B12EHTC |
| 5 | 1 | BRACKET | B122030BRKT |
| 4 | 1 | EXTERNAL HOUSING BRACKET SUPPORT | BAEHBS |
| 3 | 1 | HOUSING | B12EH |
| 2 | 1 | WIRES OUTLET JUNCTION BOX | BWOJB |
| 1 | 1 | THERMOCONNECTOR | BTHC |
| Position | Quantity | Denomination | Type / DWG. Number |
| PART LIST | | | |

FirePro. FirePro Systems Ltd Condensed aerosol genera  1200 200S

DRAWING NUMBER: ID-1200/S
DATE: 15/04/10

TITLE:
INSTALLATION DRAWING

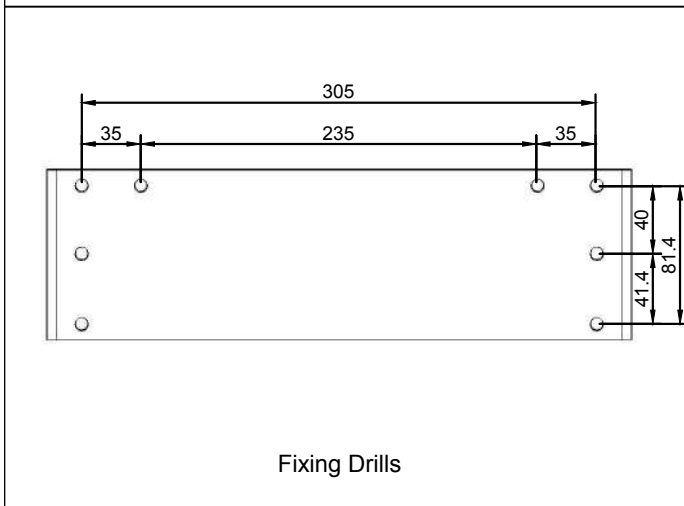
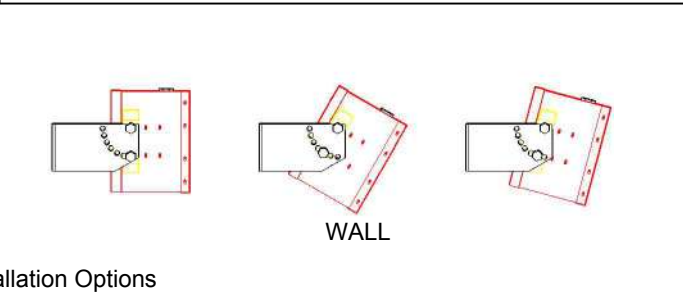
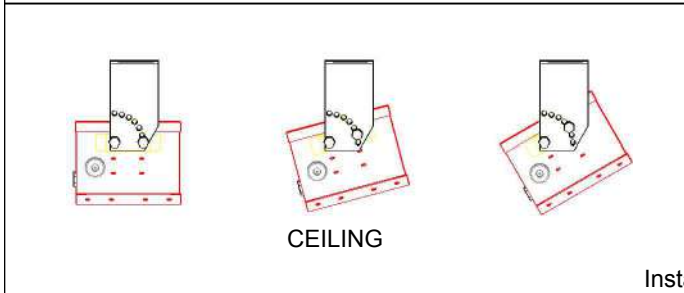
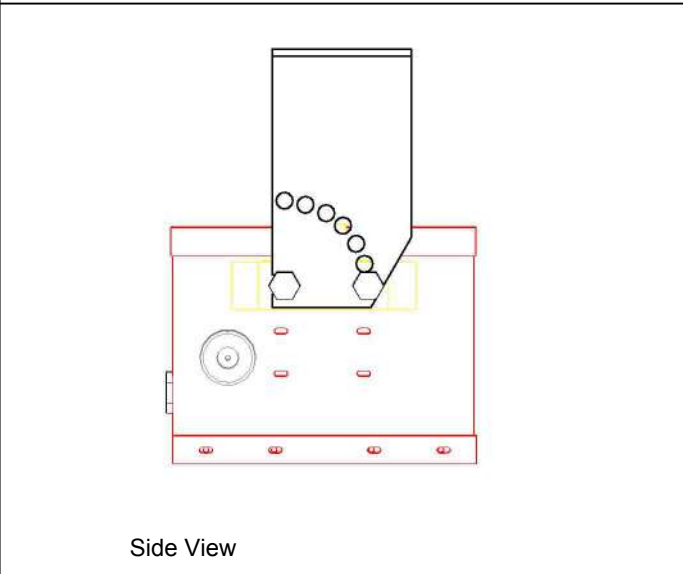
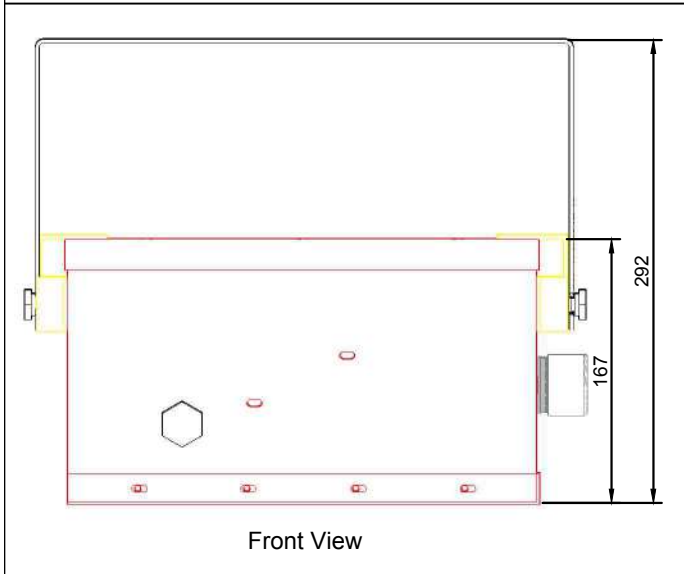
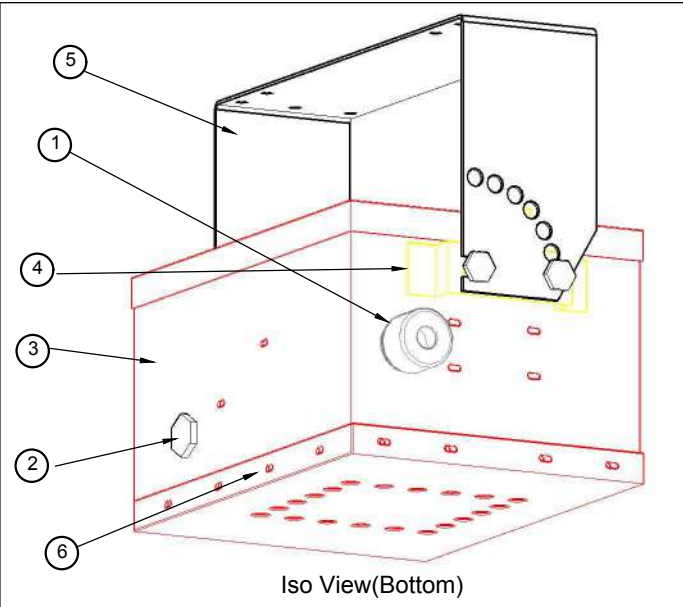
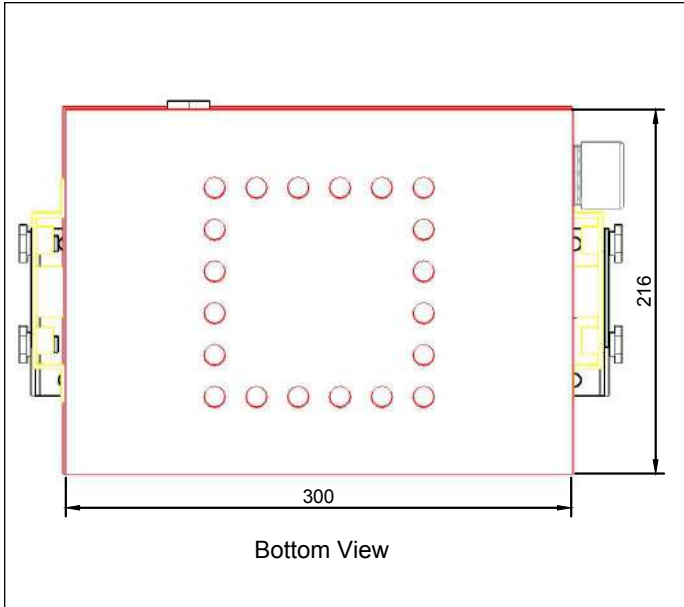

| | | | |
|------------------|----------|----------------------------------|--------------------|
| 6 | 1 | OUTLET | B12EHTC |
| 5 | 1 | BRACKET | B122030BRKT |
| 4 | 2 | EXTERNAL HOUSING BRACKET SUPPORT | BAEHBS |
| 3 | 1 | GENERATOR | B12TAS |
| 2 | 1 | BTA123 PLUG 1 | BTA123P1 |
| 1 | 1 | WIRES OUTLET JUNCTION BOX | BWOJB |
| Position | Quantity | Denomination | Type / DWG. Number |
| PART LIST | | | |

FirePro FirePro Systems Ltd FP-1200T
Condensed aerosol generator FP-1200TS

DRAWING NUMBER: ID-1200T/TS TITLE: INSTALLATION DRAWING
DATE: 05/01/16



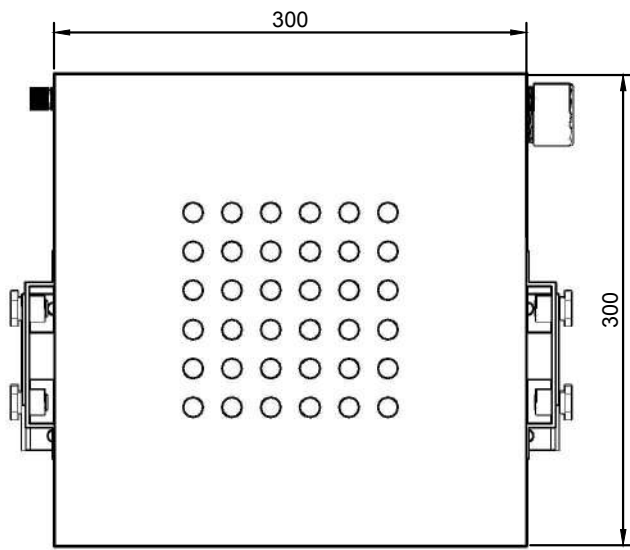

Bottom View

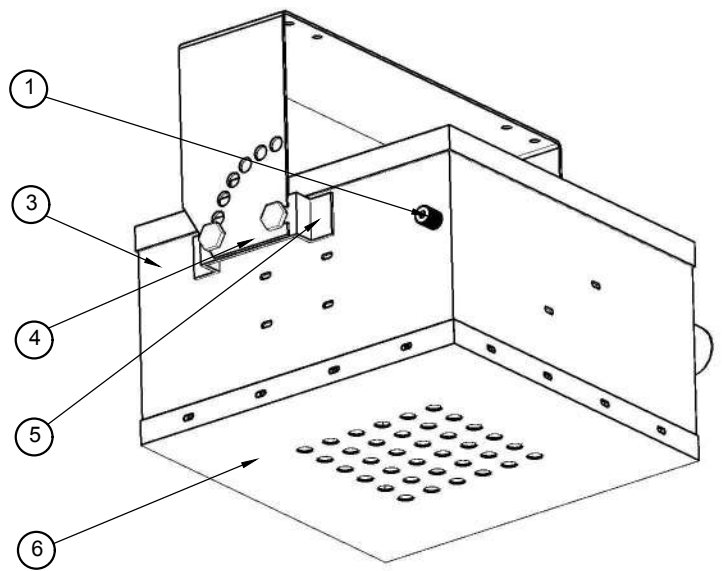

Iso View(Bottom)

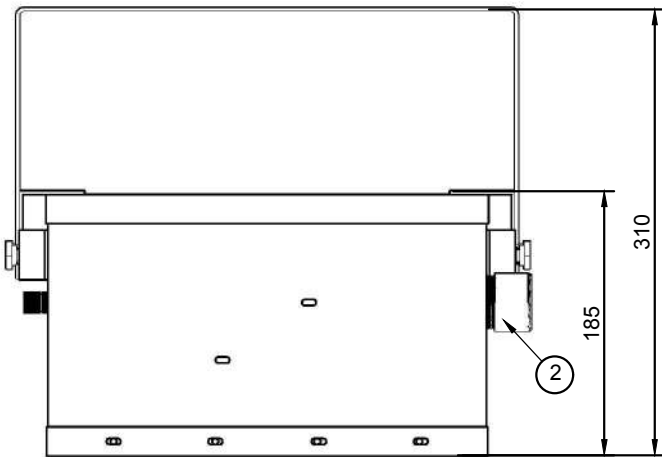

Front View

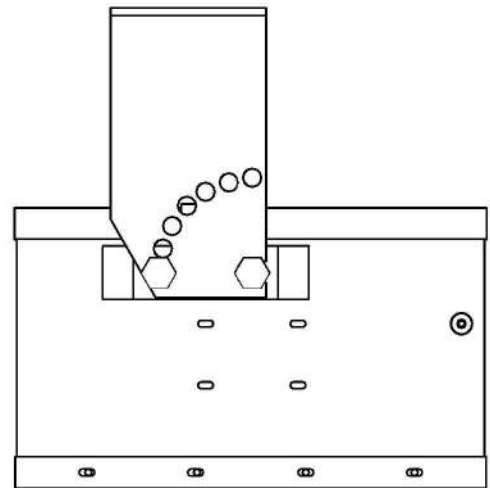

Side View

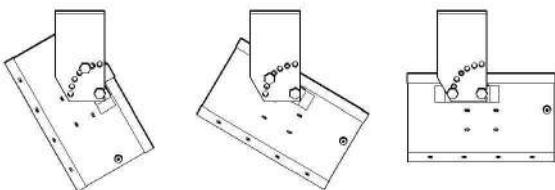

CEILING

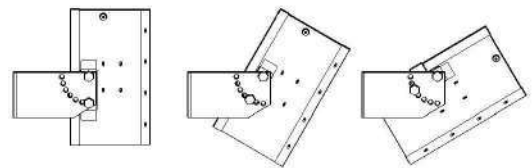

WALL

Installation Options

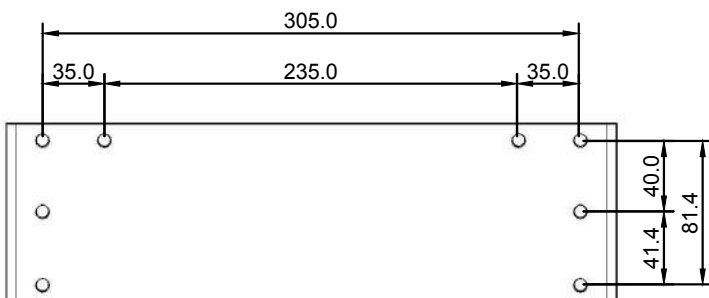

Fixing Drills

| | | | |
|------------------|----------|----------------------------------|--------------------|
| 6 | 1 | OUTLET | B203057EHTC |
| 5 | 1 | BRACKET | B122030BRKT |
| 4 | 1 | EXTERNAL HOUSING BRACKET SUPPORT | BAEHBS |
| 3 | 1 | HOUSING | B2030EHSW |
| 2 | 1 | WIRES OUTLET JUNCTION BOX | BWOJB |
| 1 | 1 | THERMOCONNECTOR | BTHC |
| Position | Quantity | Denomination | Type / DWG. Number |
| PART LIST | | | |

FirePro. FirePro Systems Ltd Condensed aerosol genera  2000 000S

DRAWING NUMBER: ID-2000/S
DATE: 15/04/10

TITLE:
INSTALLATION DRAWING

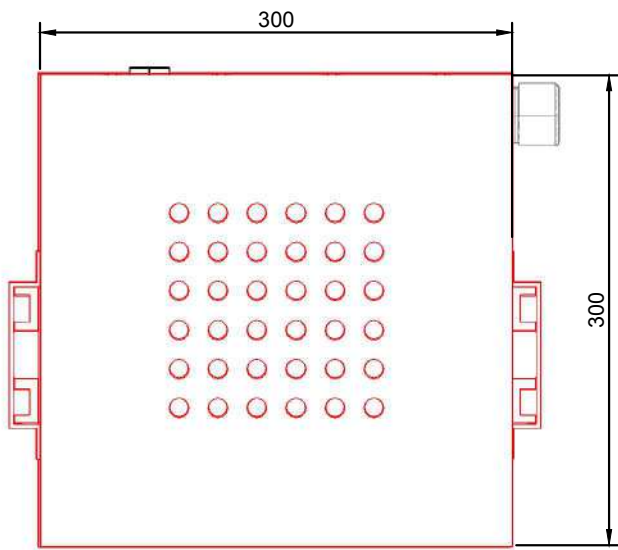

Bottom View

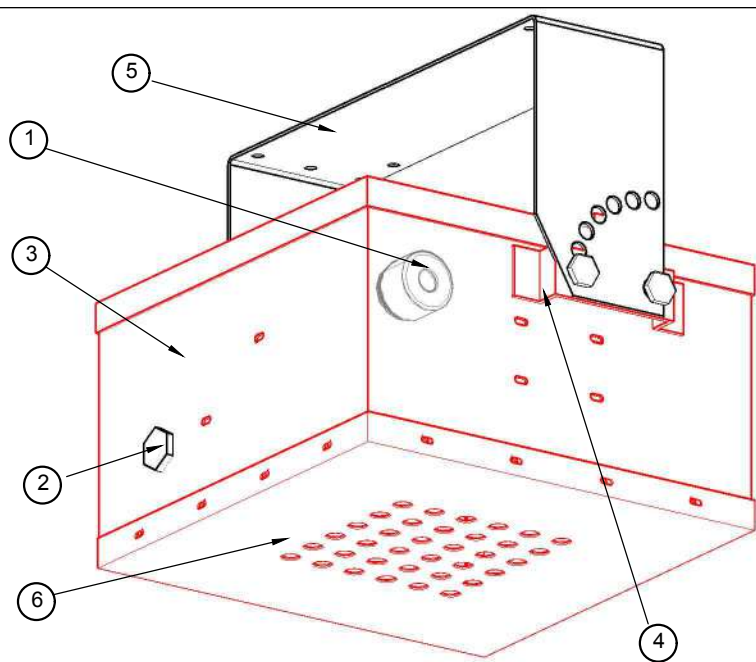

Iso View(Bottom)

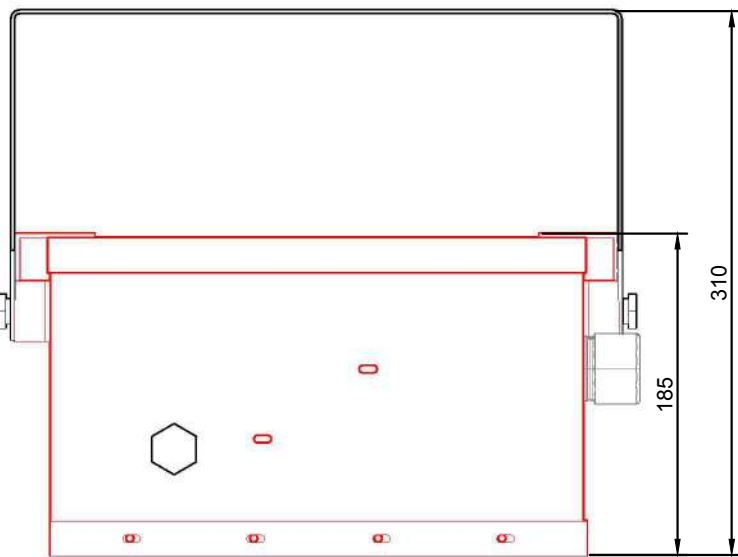

Front View

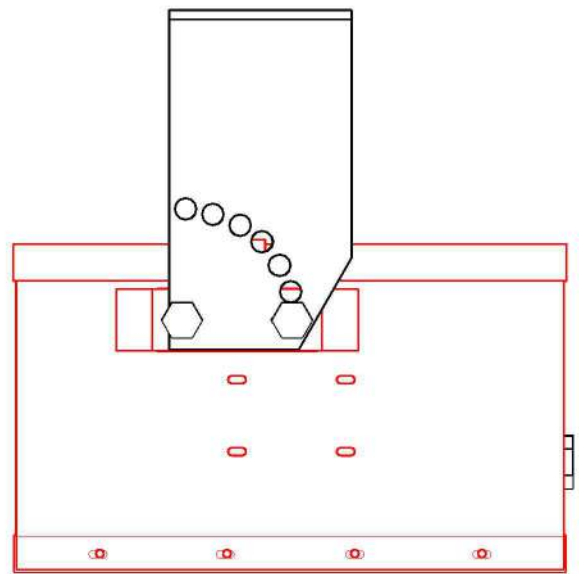

Side View

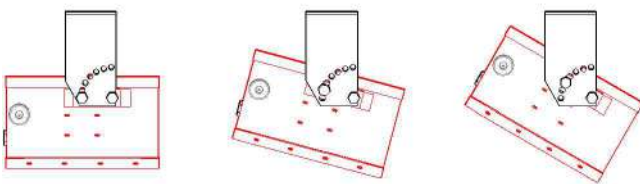

CEILING

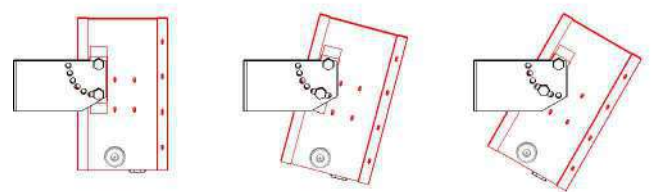

WALL

Installation Options

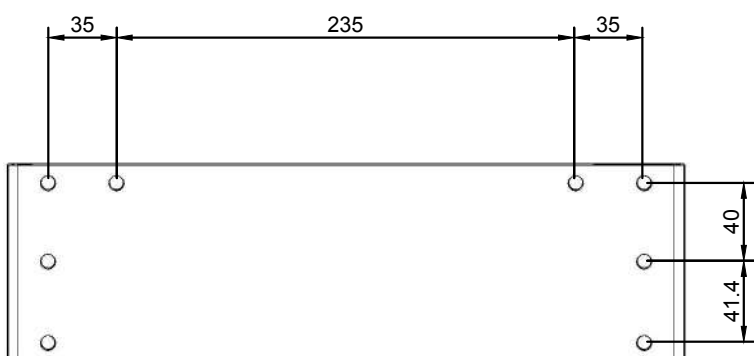

Fixing Drills

| | | | |
|------------------|----------|----------------------------------|--------------------|
| 6 | 1 | OUTLET | B203057EHTC |
| 5 | 1 | BRACKET | B122030BRKT |
| 4 | 2 | EXTERNAL HOUSING BRACKET SUPPORT | BAEHBS |
| 3 | 1 | GENERATOR | B20TAS |
| 2 | 1 | BTA123 PLUG 1 | BTA123P1 |
| 1 | 1 | WIRES OUTLET JUNCTION BOX | BWOJB |
| Position | Quantity | Denomination | Type / DWG. Number |
| PART LIST | | | |

FirePro Systems Ltd. 2000T
FirePro. Condensed aerosol generat *Shuvo* 000TS
LE. MARKA LAJUNA MURCI 1991-2007 0703

DRAWING NUMBER: ID-2000T/TS
 DATE: 05/01/16

TITLE:
 INSTALLATION DRAWING

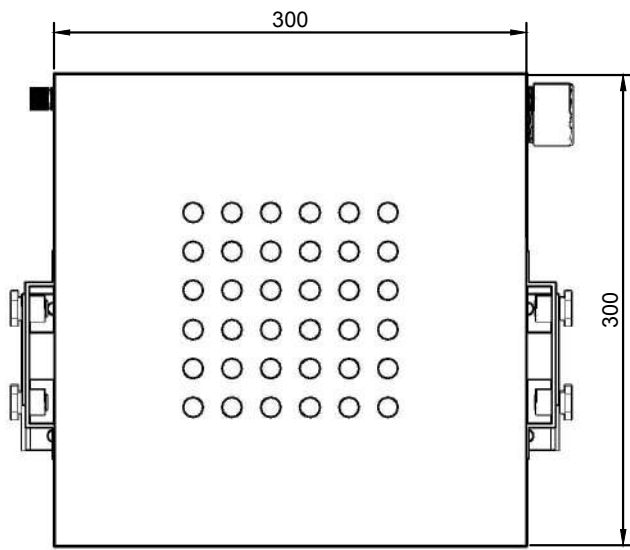

Bottom View

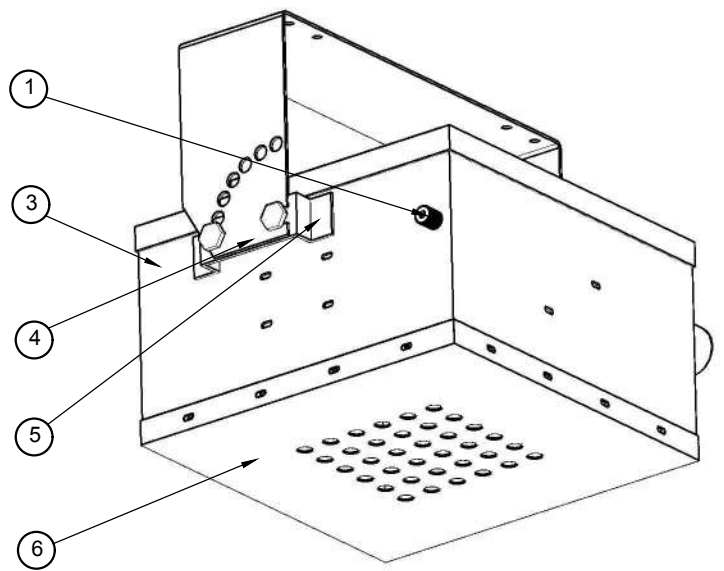

Iso View(Bottom)

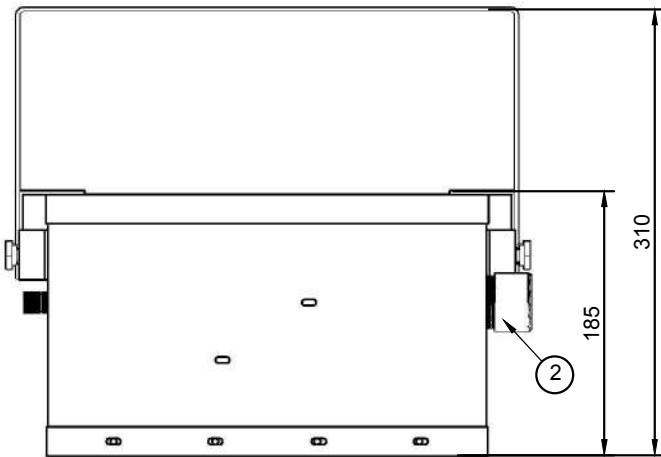

Front View

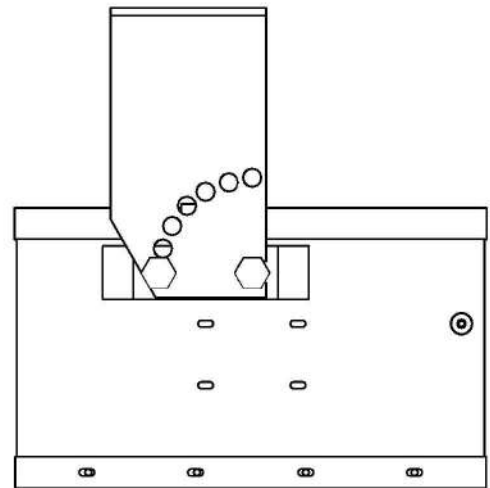

Side View

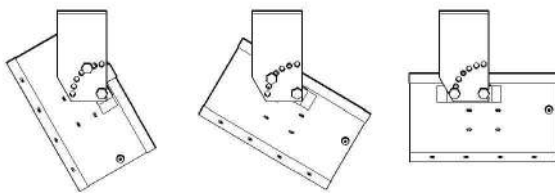

CEILING

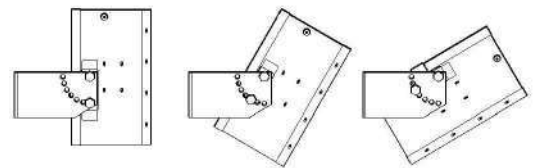

WALL

Installation Options

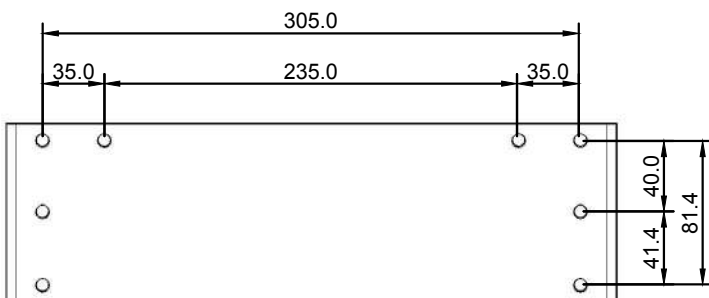

Fixing Drills

| | | | |
|------------------|----------|----------------------------------|--------------------|
| 6 | 1 | OUTLET | B203057EHTC |
| 5 | 1 | BRACKET | B122030BRKT |
| 4 | 1 | EXTERNAL HOUSING BRACKET SUPPORT | BAEHBS |
| 3 | 1 | HOUSING | B2030EHSW |
| 2 | 1 | WIRES OUTLET JUNCTION BOX | BWOJB |
| 1 | 1 | THERMOCONNECTOR | BTHC |
| Position | Quantity | Denomination | Type / DWG. Number |
| PART LIST | | | |

FirePro. FirePro Systems Ltd Condensed aerosol genera  -3000 000S

DRAWING NUMBER: ID-3000/S
DATE: 15/04/10

TITLE:
INSTALLATION DRAWING

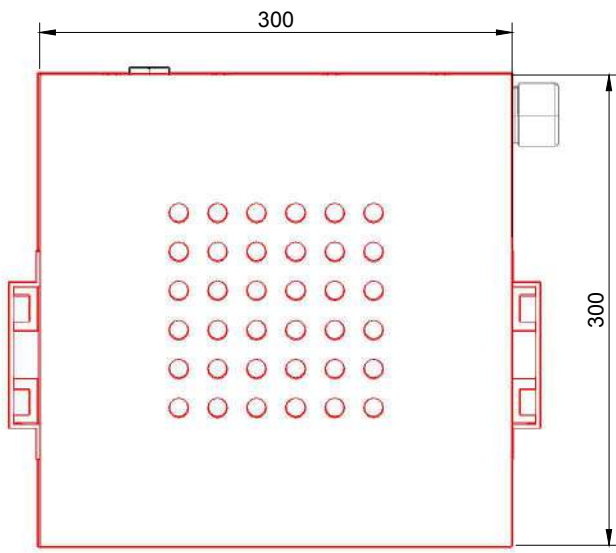

Bottom View

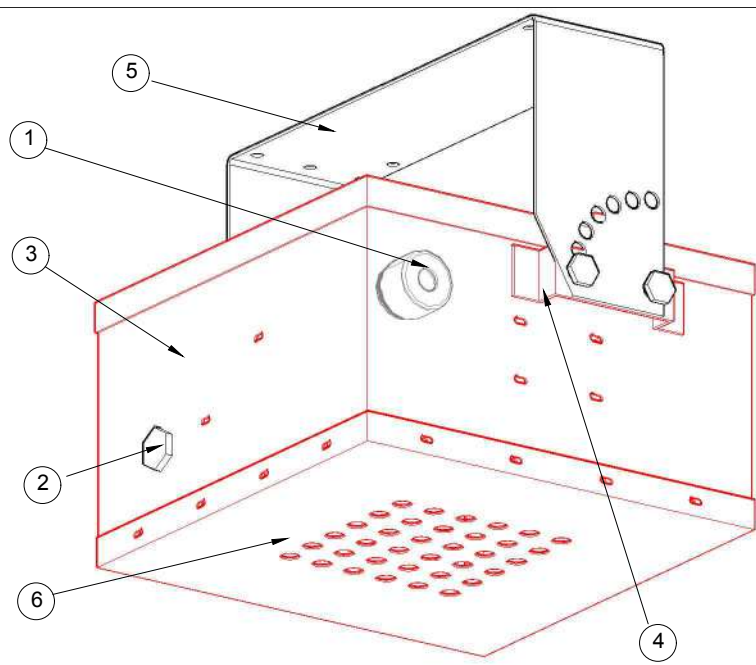

Iso View(Bottom)

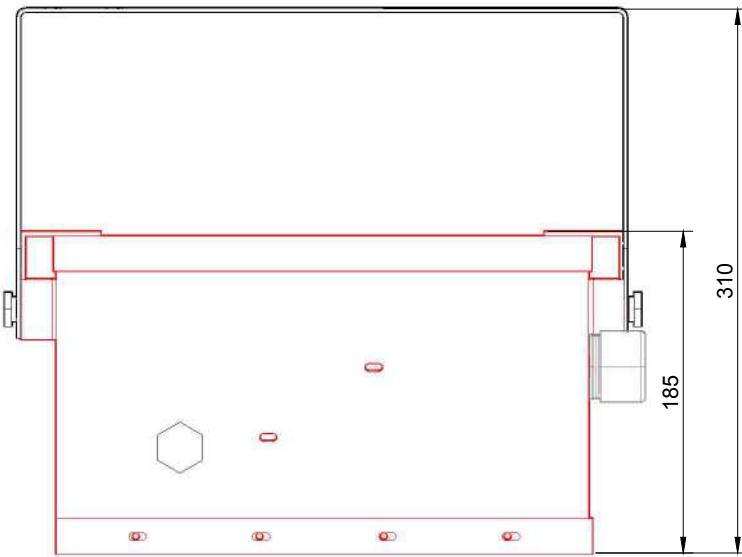

Front View

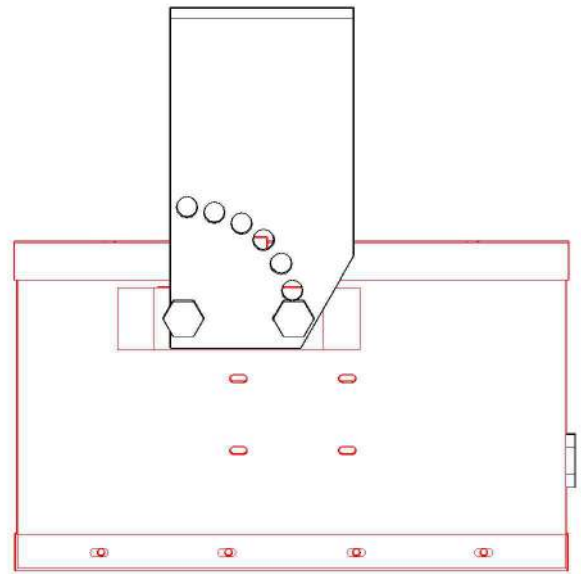

Side View

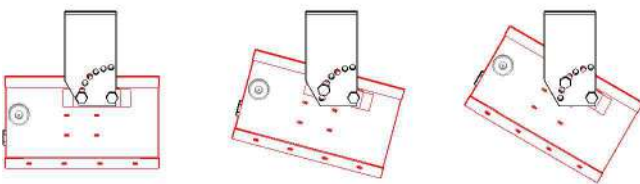

CEILING

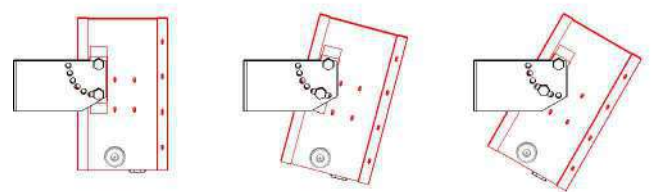

WALL

Installation Options

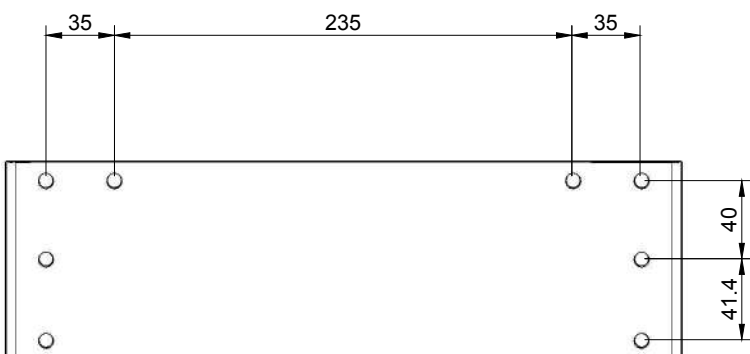

Fixing Drills

| | | | |
|------------------|----------|----------------------------------|--------------------|
| 6 | 1 | OUTLET | B203057EHTC |
| 5 | 1 | BRACKET | B122030BRKT |
| 4 | 2 | EXTERNAL HOUSING BRACKET SUPPORT | BAEHBS |
| 3 | 1 | GENERATOR | B30TAS |
| 2 | 1 | BTA123 PLUG 1 | BTA123P1 |
| 1 | 1 | WIRES OUTLET JUNCTION BOX | BWOJB |
| Position | Quantity | Denomination | Type / DWG. Number |
| PART LIST | | | |

FirePro Systems Ltd. 3000T
FirePro. Condensed aerosol generat *Shaw* 000TS
LE MARKA LAJUNA MURGO
 KIP-3000T
 010

DRAWING NUMBER: ID-3000T/TS
 DATE: 05/01/16

TITLE:
 INSTALLATION DRAWING

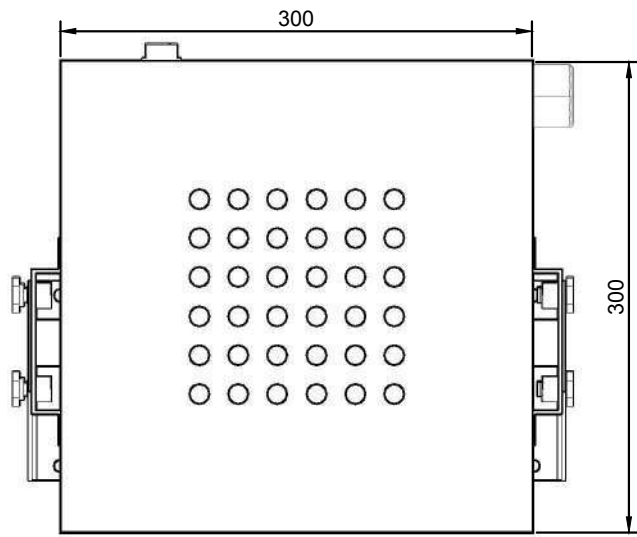

Bottom View

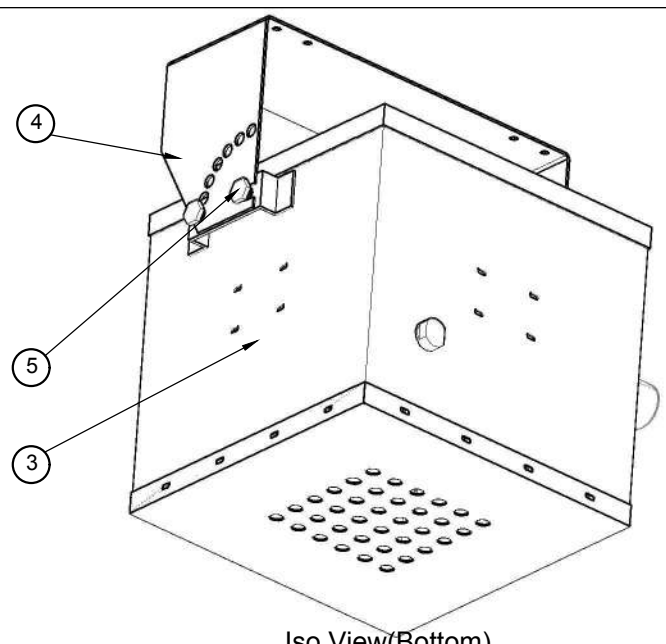

Iso View(Bottom)

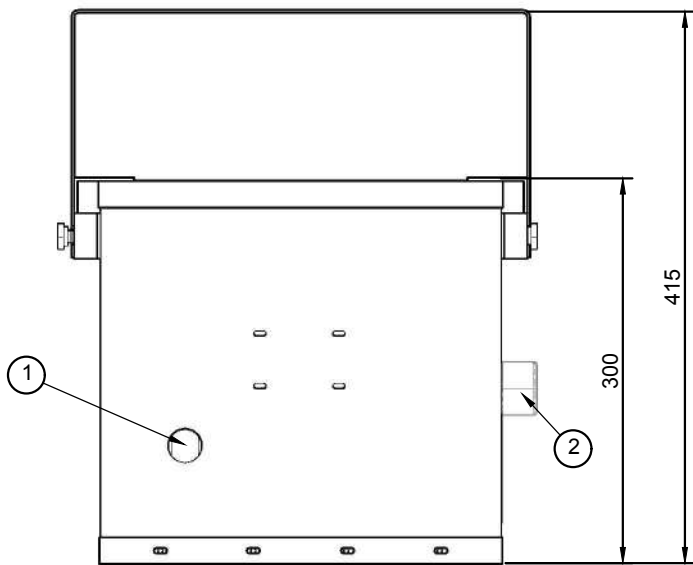

Front View

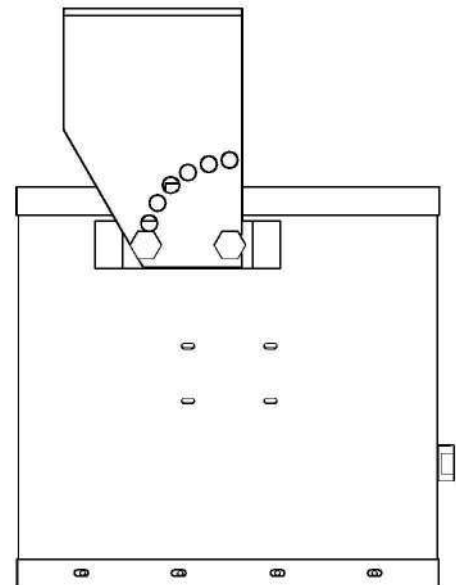

Side View

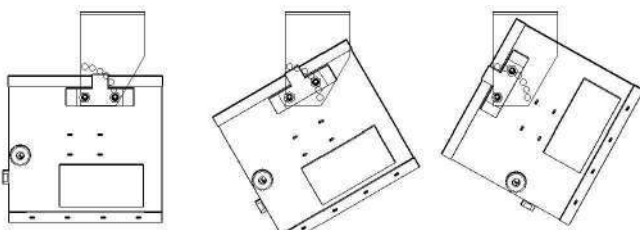

CEILING

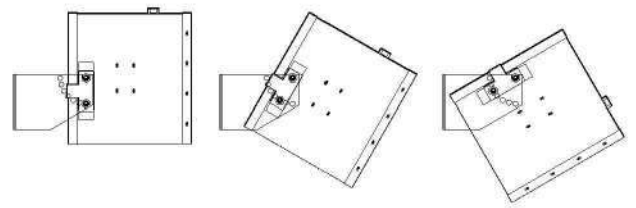

WALL

Installation Options

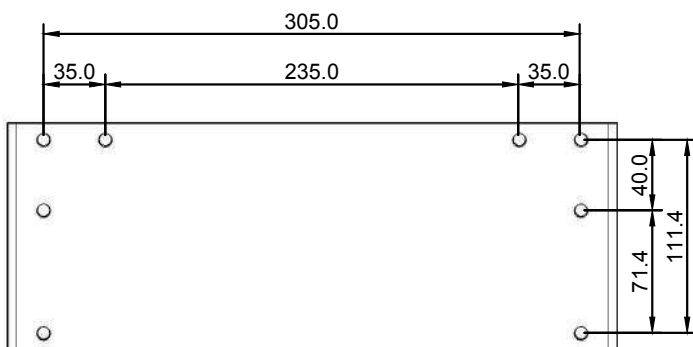

Fixing Drills

| | | | |
|------------------|----------|---------------------------|--------------------|
| 5 | 2 | BOLT FOR BRACKET SUPPORT | BABBS |
| 4 | 1 | BRACKET | B57BRKT |
| 3 | 1 | GENERATOR | B42AS |
| 2 | 1 | WIRES OUTLET JUNCTION BOX | BWOJB |
| 1 | 1 | BTA PLUG1 | BTAP1 |
| Position | Quantity | Denomination | Type / DWG. Number |
| PART LIST | | | |

FirePro. FirePro Systems Ltd Condensed aerosol genera  4200T 200TS

DRAWING NUMBER: ID-4200T/TS
DATE: 02/10/14

TITLE:
INSTALLATION DRAWING

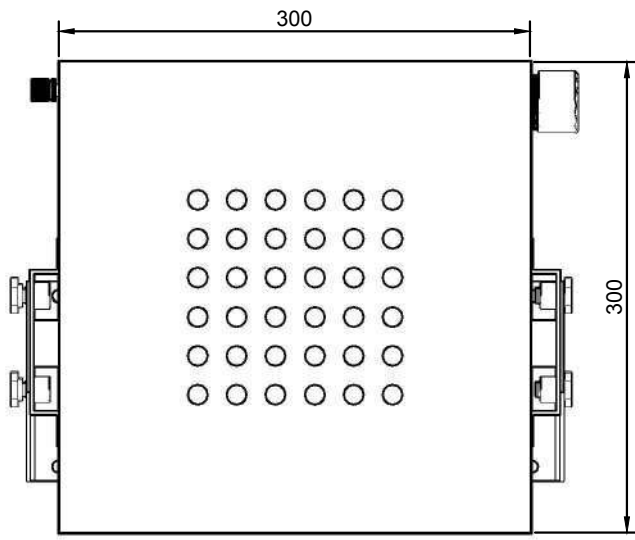

Bottom View

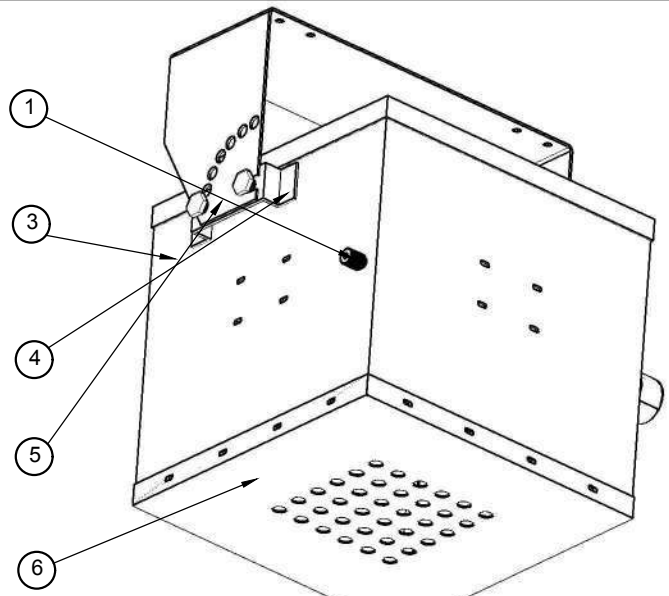

Iso View(Bottom)

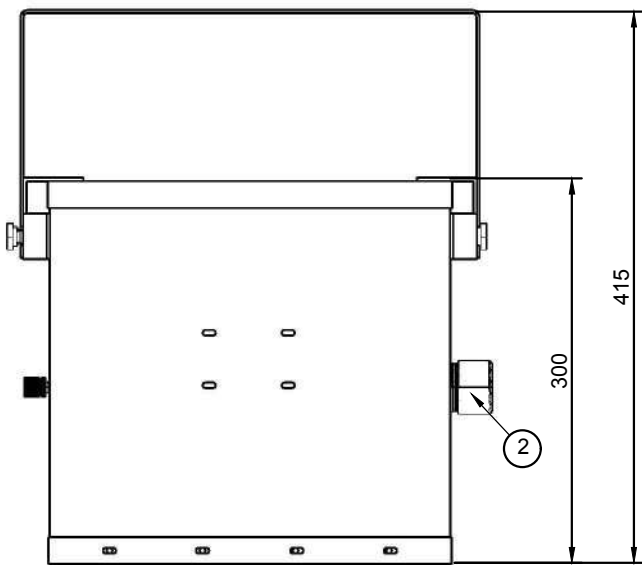

Front View

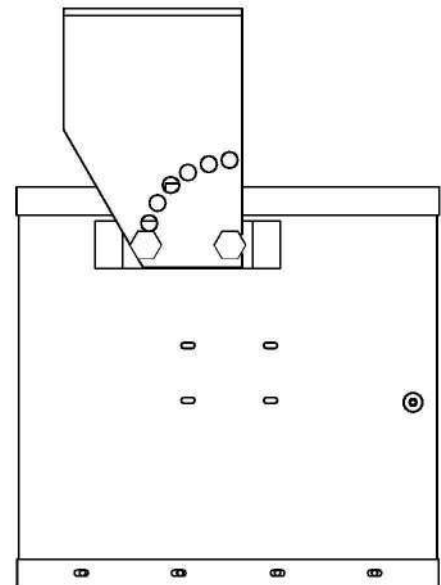

Side View

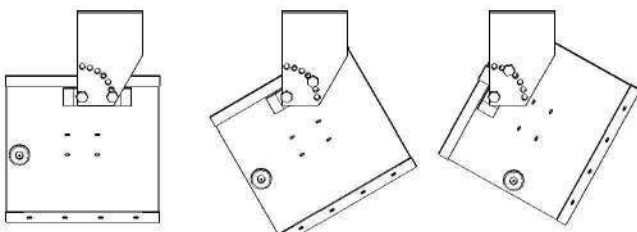

CEILING

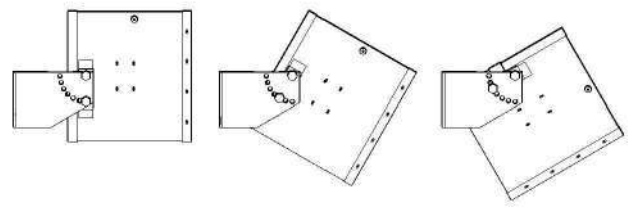

WALL

Installation Options

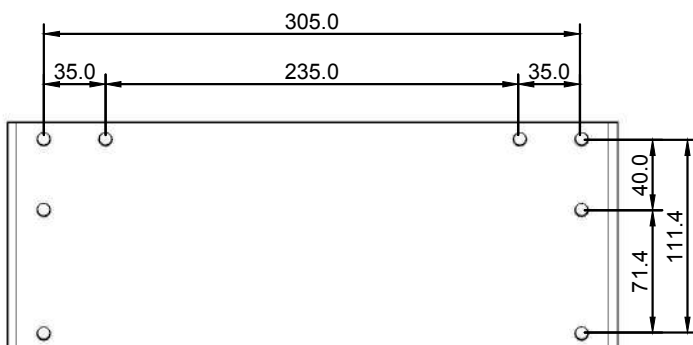

Fixing Drills

| | | | |
|------------------|----------|----------------------------------|--------------------|
| 6 | 1 | OUTLET | B203057EHTC |
| 5 | 1 | BRACKET | B57BRKT |
| 4 | 1 | EXTERNAL HOUSING BRACKET SUPPORT | BAEHBS |
| 3 | 1 | HOUSING | B57EHSW |
| 2 | 1 | WIRES OUTLET JUNCTION BOX | BWOJB |
| 1 | 1 | THERMOCONNECTOR | BTHC |
| Position | Quantity | Denomination | Type / DWG. Number |
| PART LIST | | | |

FirePro *FirePro Systems Ltd* Condensed aerosol genera  5700 700S

DRAWING NUMBER: ID-5700/S
DATE: 15/04/10

TITLE:
INSTALLATION DRAWING

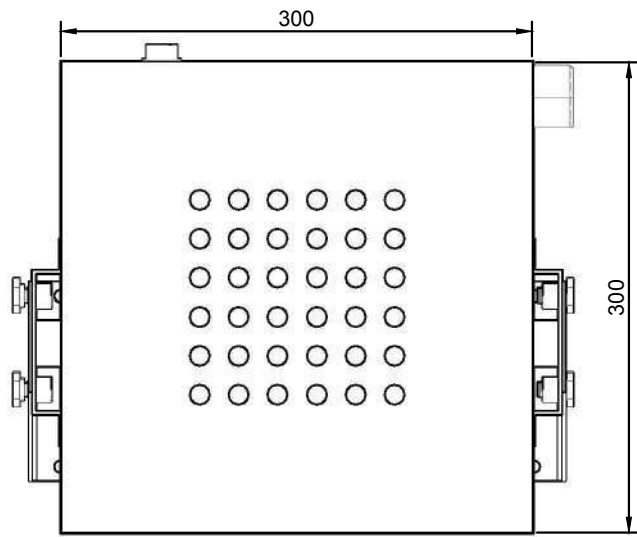

Bottom View

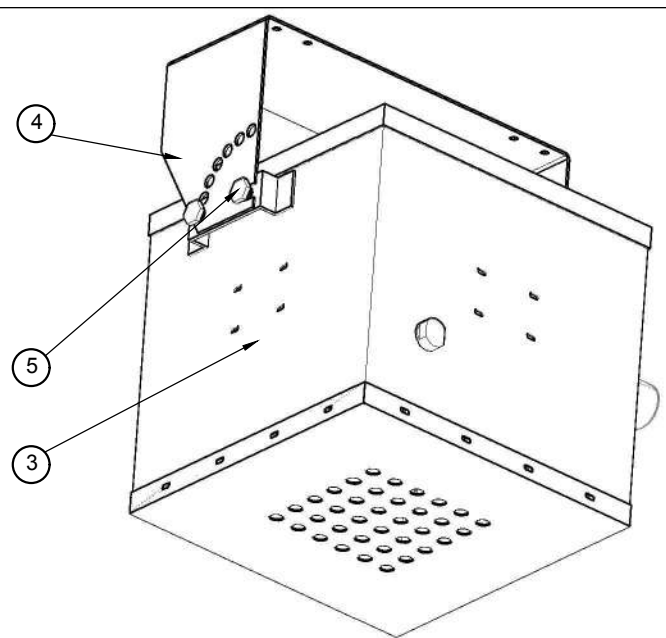

Iso View(Bottom)

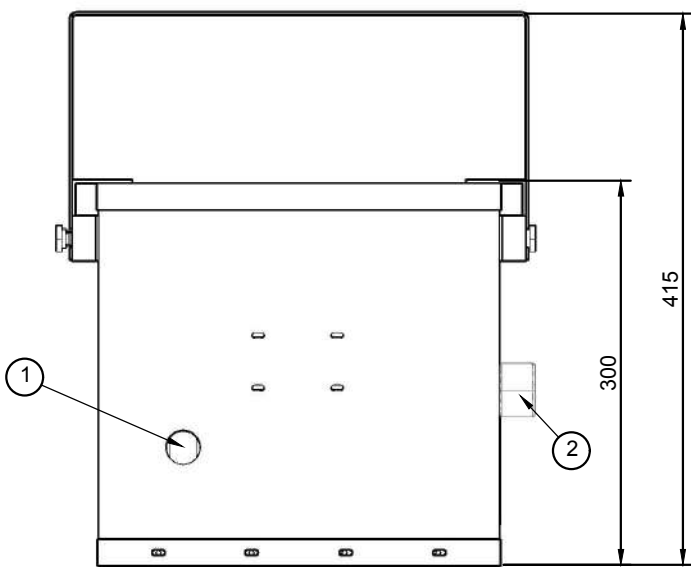

Front View

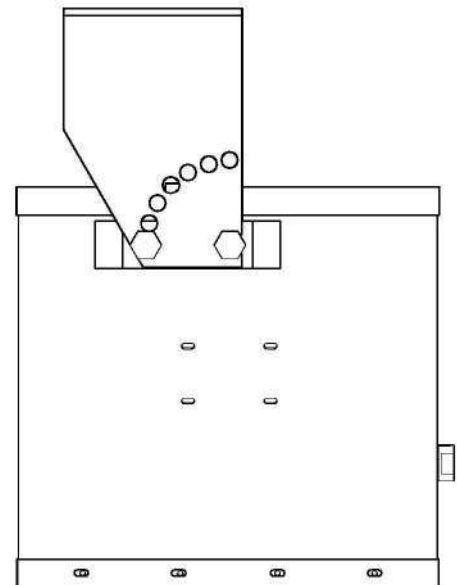

Side View

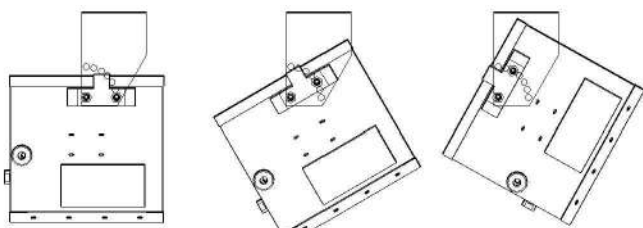

CEILING

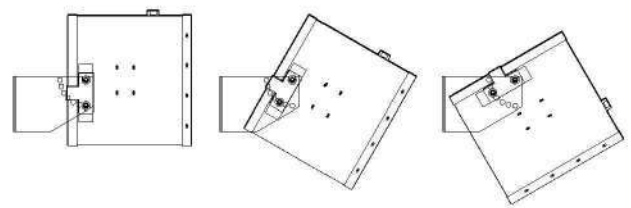

WALL

Installation Options

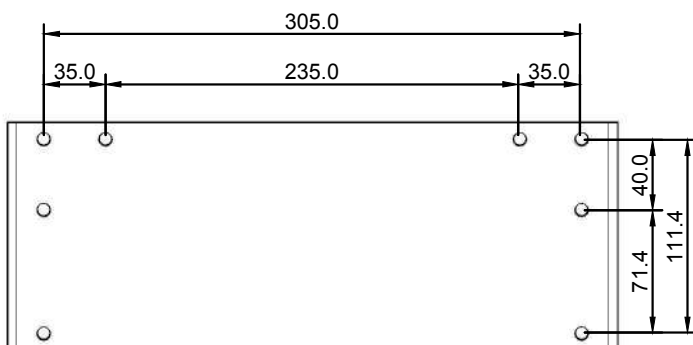

Fixing Drills

| 5 | 2 | BOLT FOR BRACKET SUPPORT | BABBS |
|------------------|----------|---------------------------|--------------------|
| 4 | 1 | BRACKET | B57BRKT |
| 3 | 1 | GENERATOR | B57TAS |
| 2 | 1 | WIRES OUTLET JUNCTION BOX | BWOJB |
| 1 | 1 | BTA PLUG1 | BTAP1 |
| Position | Quantity | Denomination | Type / DWG. Number |
| PART LIST | | | |

FirePro. FirePro Systems Ltd Condensed aerosol genera  5700T 700TS

DRAWING NUMBER: ID-5700T/TS
DATE: 05/01/16

TITLE:
INSTALLATION DRAWING

FirePro

Appendix 2

SYSTEM SOLUTIONS

To be read and used in conjunction with
FirePro Information, Instruction & User Manual
Version 8, May 2020

FirePro Systems Ltd

8 Faleas Str. ,CY-4101 Limassol, CYPRUS

Tel. +357 25 379999, Fax. +357 25 354432

Web: www.firepro.com, email: mail@firepro.com

An ISO 9001:2015 & ISO 14001:2015 registered company

FirePro Fire Extinguishing Aerosol System Block Diagram (Using Smoke and Rate of Rise Heat Detectors)

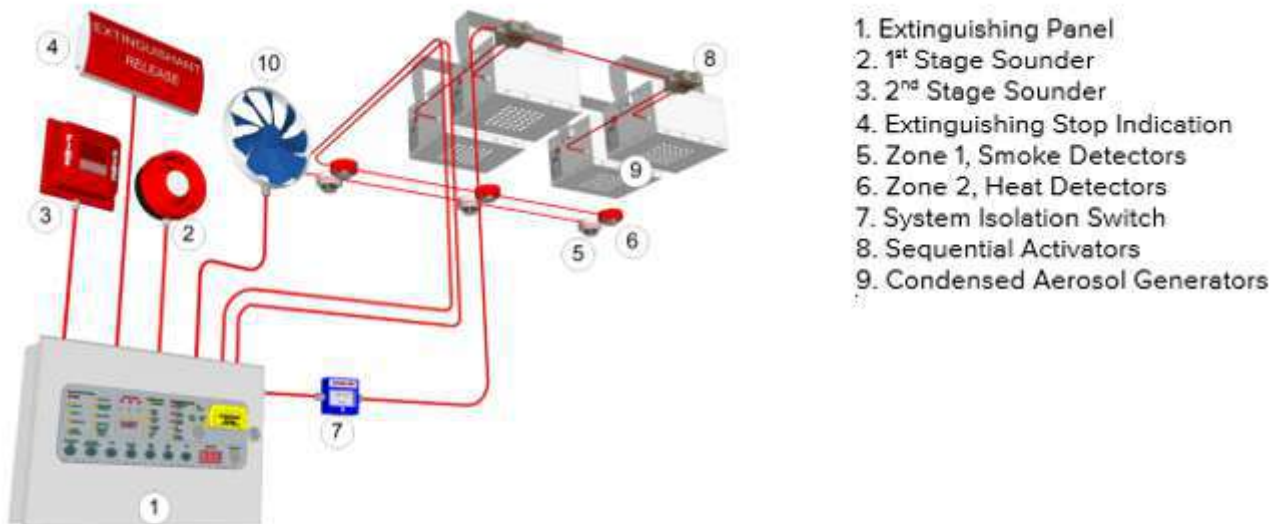

- An E.P.O. System (Emergency Power-Off System) should be installed and activated prior the release of the fire extinguishing agent.
- Stage 1 Alarm: Air Dumpers, Ventilation System and Air-Conditioning to be powered off.
- Stage 2 Alarm: Emergency power off of all electronic & electrical equipment.

FirePro Fire Extinguishing Aerosol System Block Diagram (Using Linear Heat Detectors)

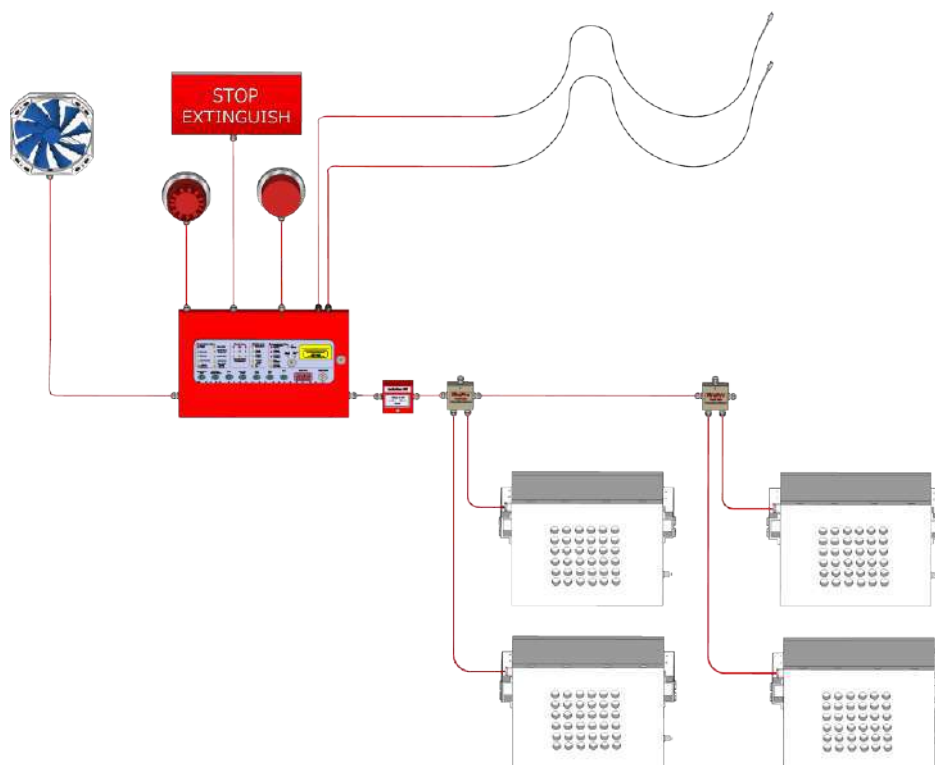

Multiple configuration System

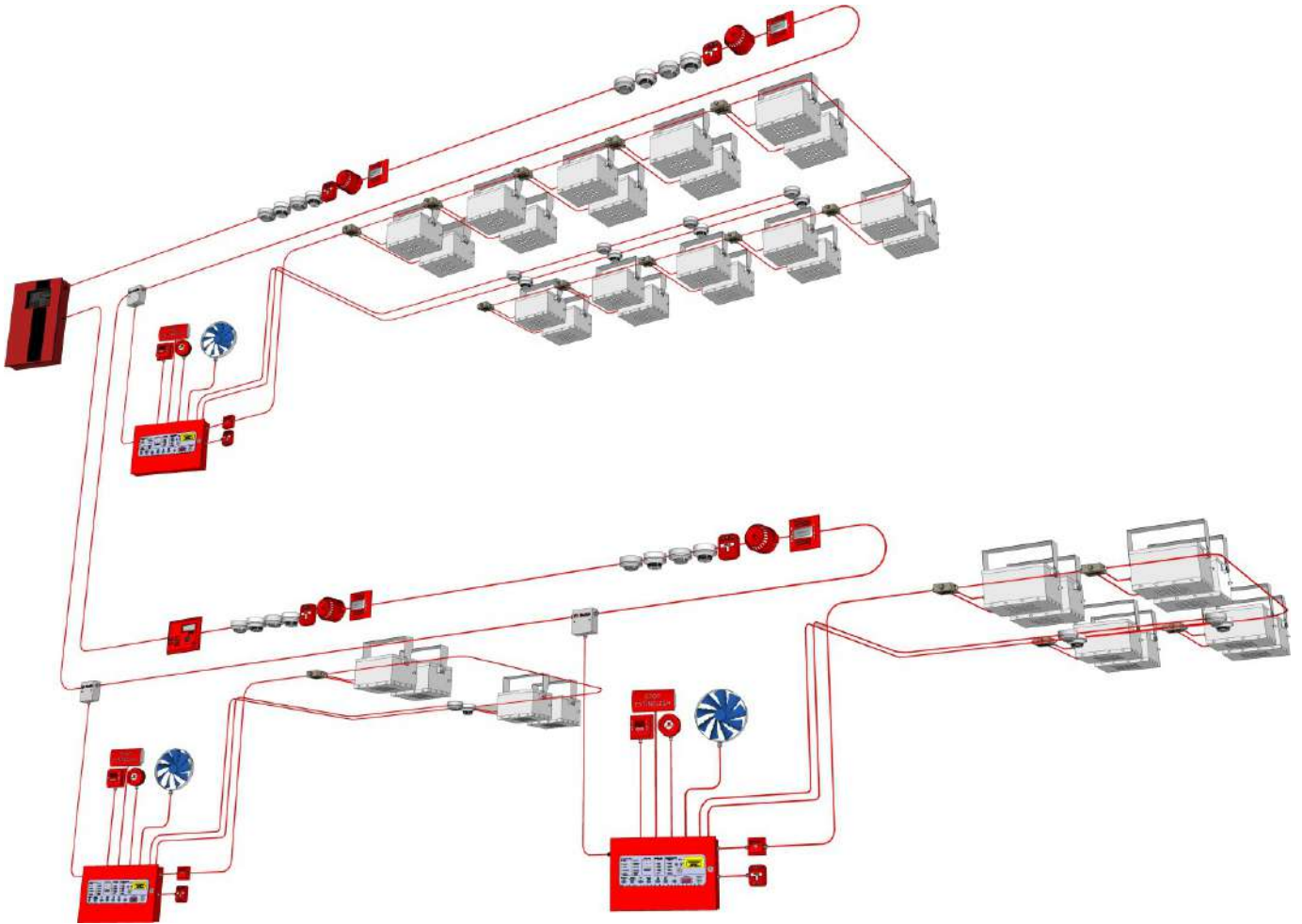

FPC-2 module - Single Panel Enclosure Protection

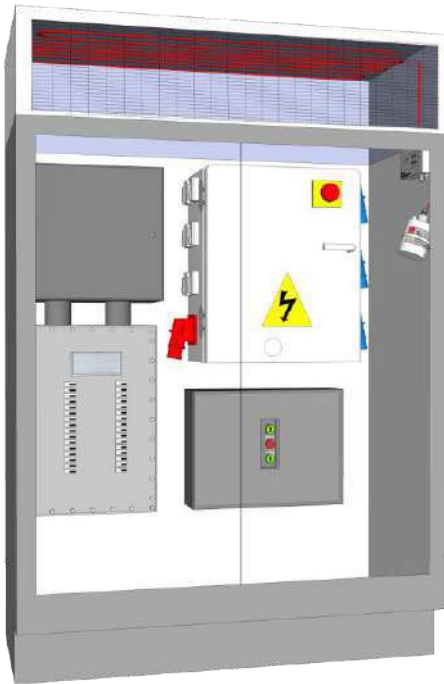

1. 24v power In / Out
2. Single Zone detection.
3. Four Aerosol Generators can be connected.
4. Fire contacts for remote signalling
5. Fault contacts for remote signalling
6. Connection to addressable module.

FPC-2 module - FirePro Multiple Panel Enclosure Protection

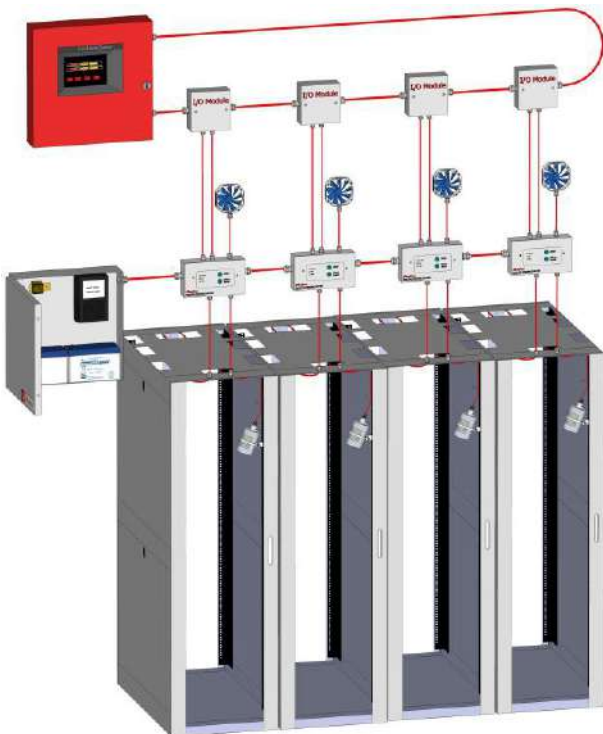

1. 24v power In / Out
2. Single Zone detection.
3. Four Aerosol Generators can be connected.
4. Fire contacts for remote signalling
5. Fault contacts for remote signalling
6. Connection to addressable module.

FPC-1 module – Battery operated stand alone module for single panel protection with build in thermal detection

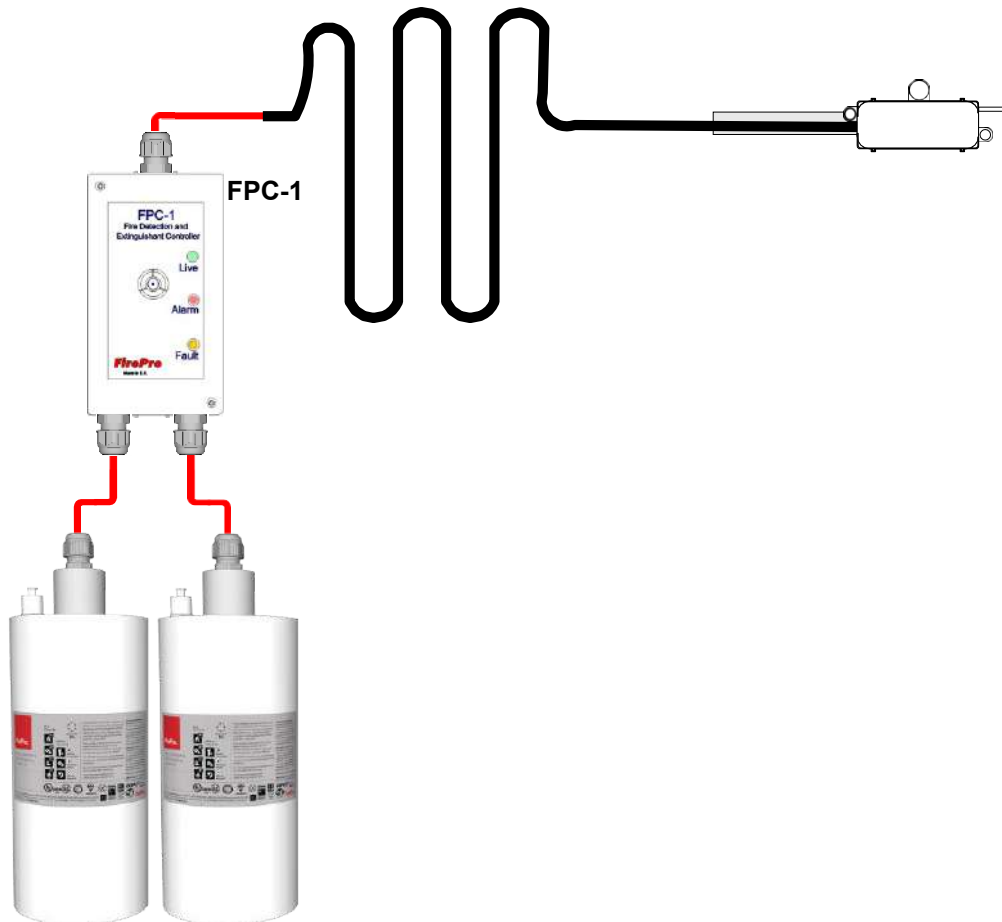

1. Operating voltage 6v (4 AA batteries 1.5v)
2. Battery operating time 2-3 years.
3. Activation temperature – Fixed Temperature 80 °C
4. Activation temperature – Rate of Rise 8 °C/minute, if over 40 °C
5. or Fixed Temperature 80 °C
6. Remote Activation End of Line Resistor 5.1 K Ohm
7. Single Zone detection.
8. Two Aerosol Generators can be connected.
9. Fire alarm open collector connection.
10. Faults alarm open collector connection.
11. Watchdog alarm open collector connection.

FPC-4RM module – Battery operated stand alone module upto two aerosol generators

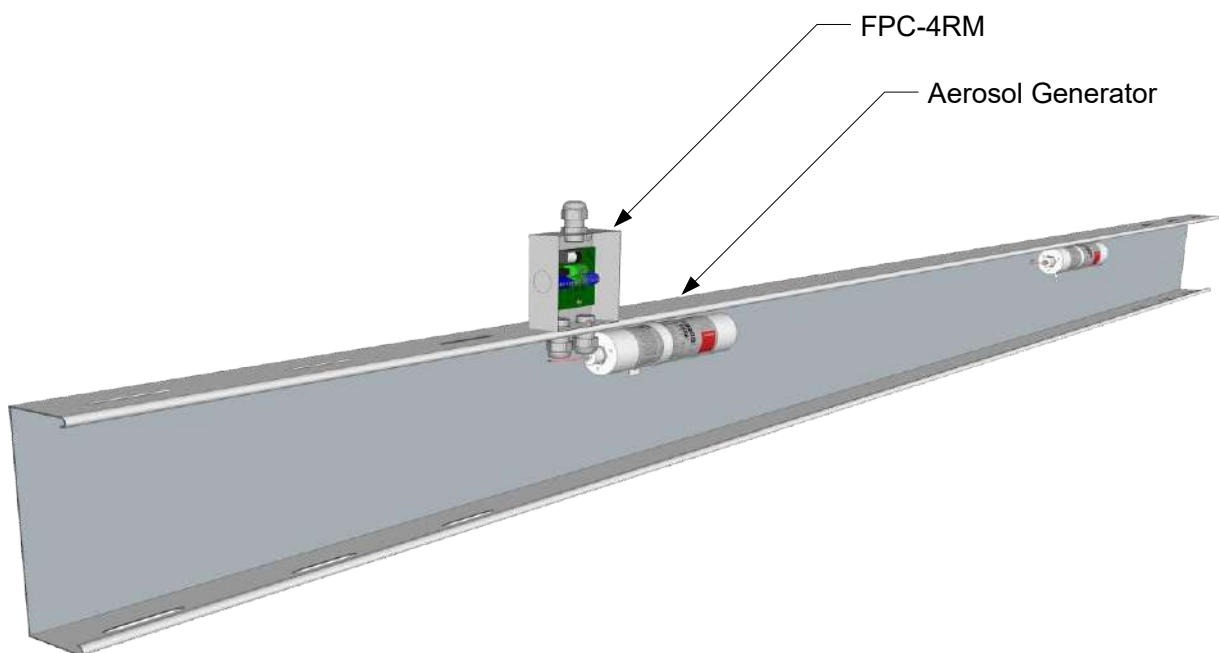
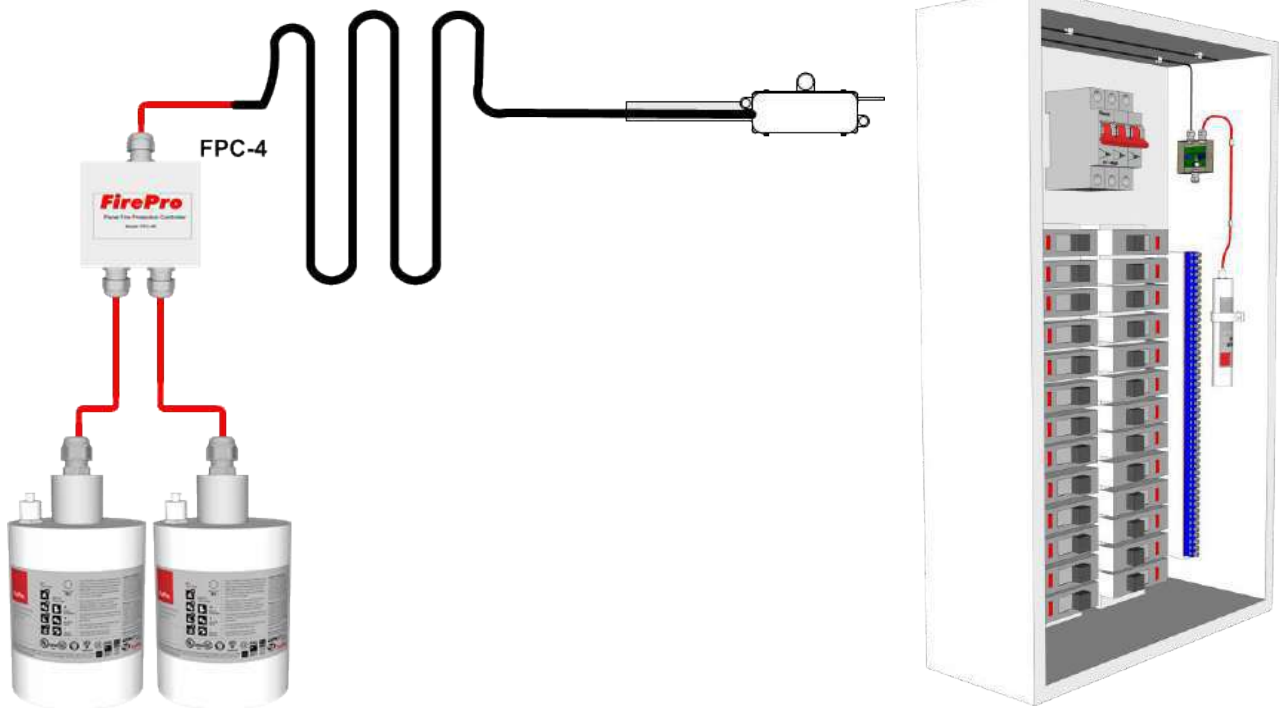

FPC-5 module – Battery operated stand alone module for single aerosol generator

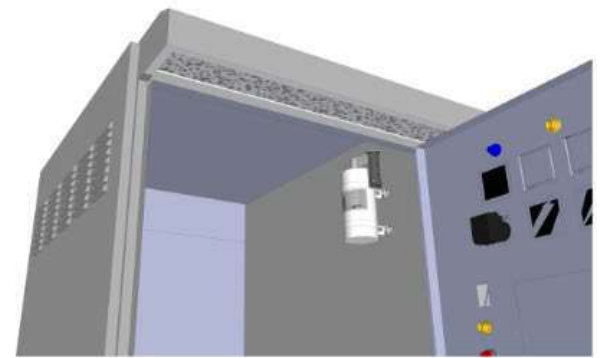
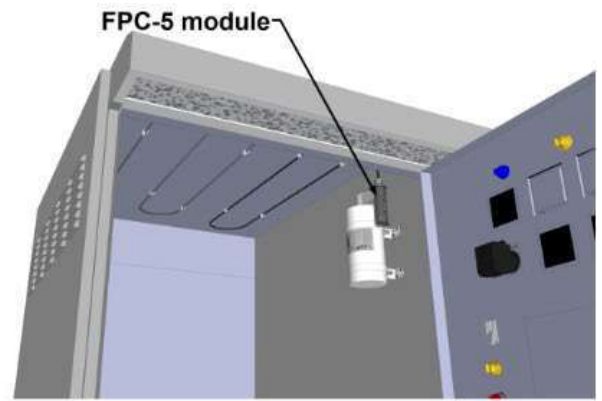
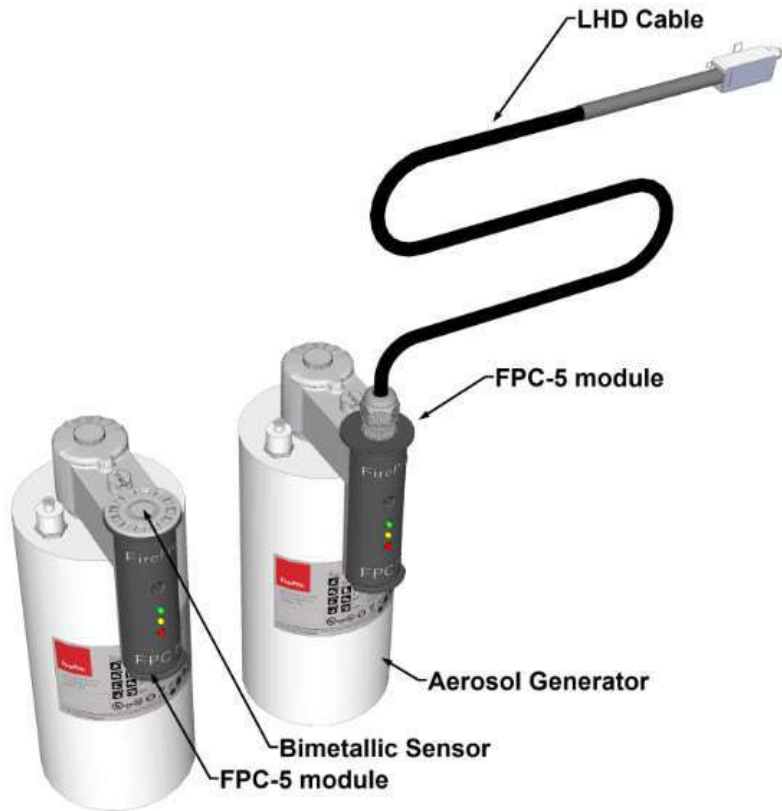

Bulb Thermal Actuator for single aerosol generator

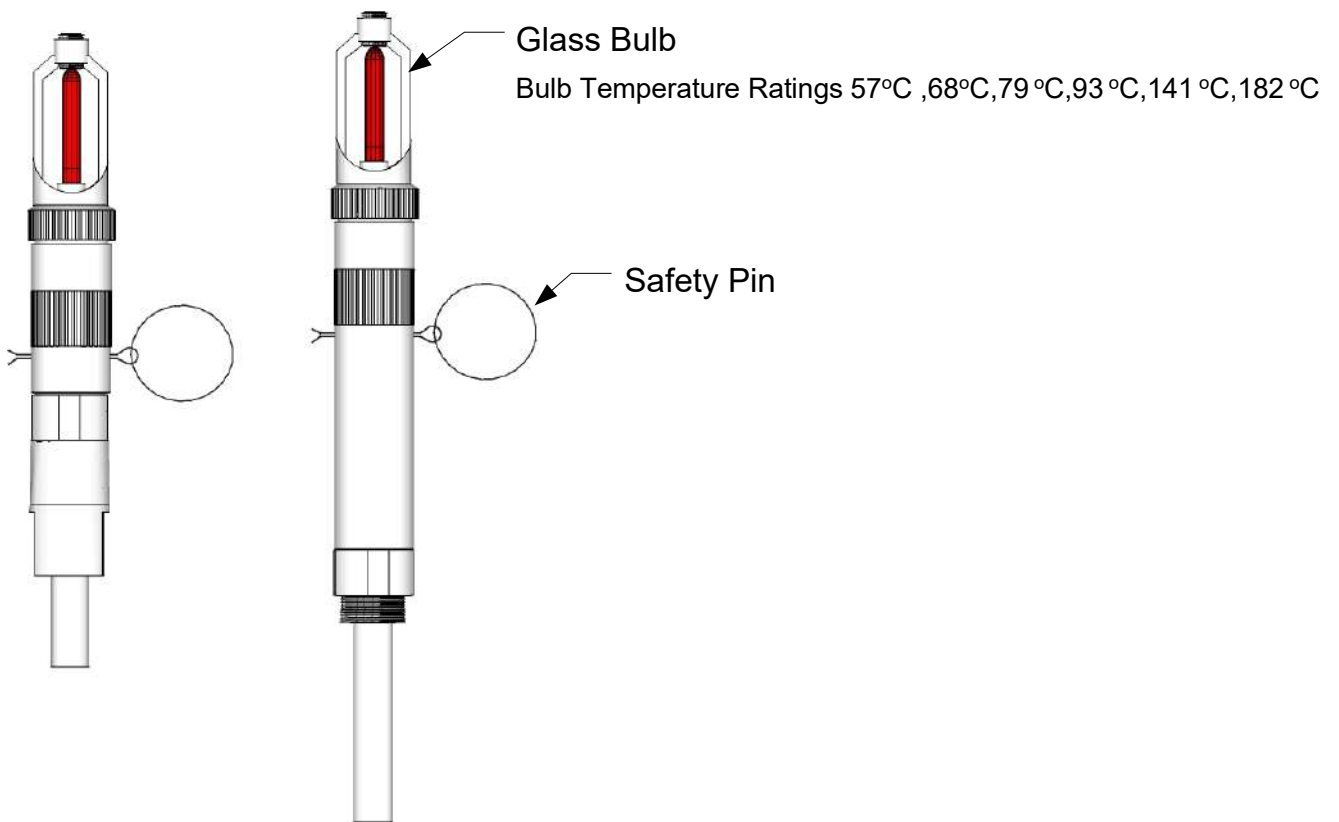
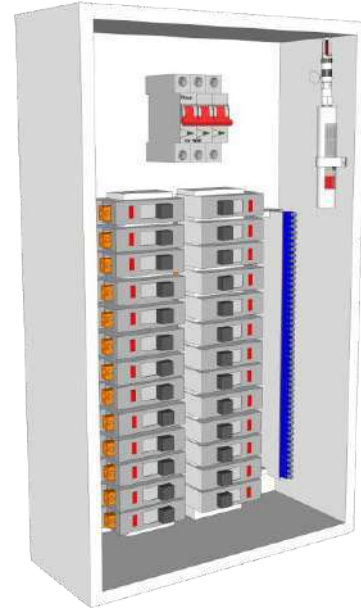
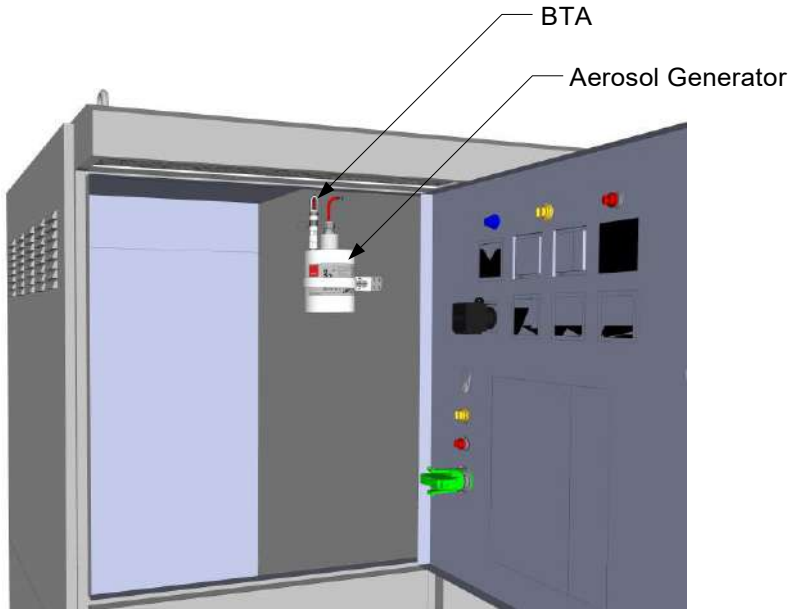

FPX114 Module, Auto Activation & Battery Powered, for fire suppression systems in vehicles.

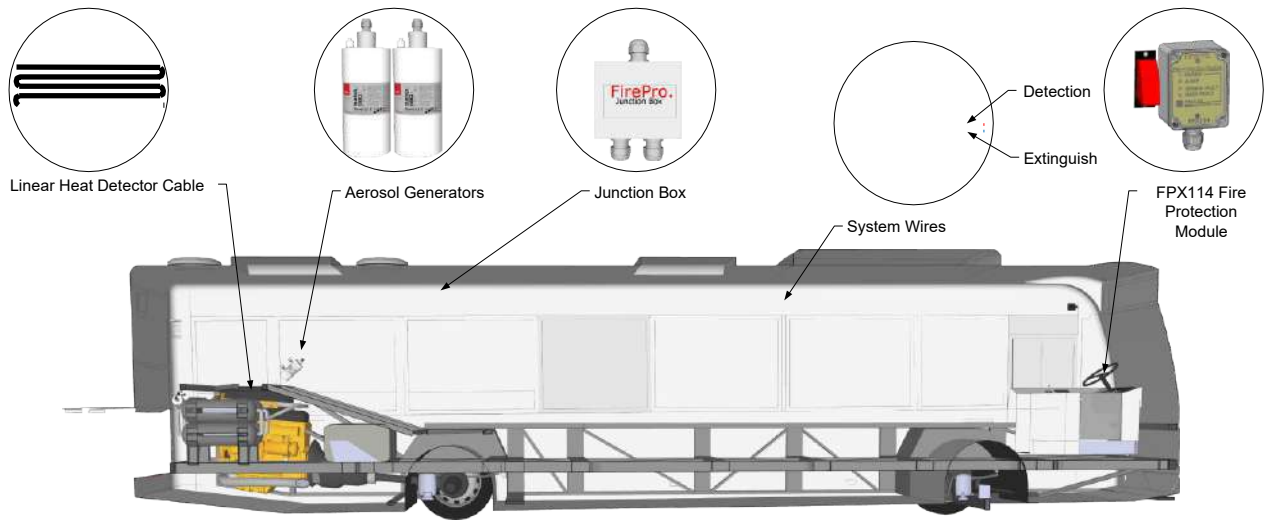

FirePro

Appendix 3

Internal Enclosures Protection – Generators Positioning

To be read and used in conjunction with
FirePro Information, Instruction & User
Manual Version 8, May 2020

FirePro Systems Ltd

8 Faleas Str., CY-4101 Limassol, CYPRUS
Tel. +357 25 379999, Fax. +357 25 354432
Web: www.firepro.com, email: mail@firepro.com
An ISO 9001:2015 & ISO 14001:2015 registered company

Positioning of FirePro FP-20SE Generator

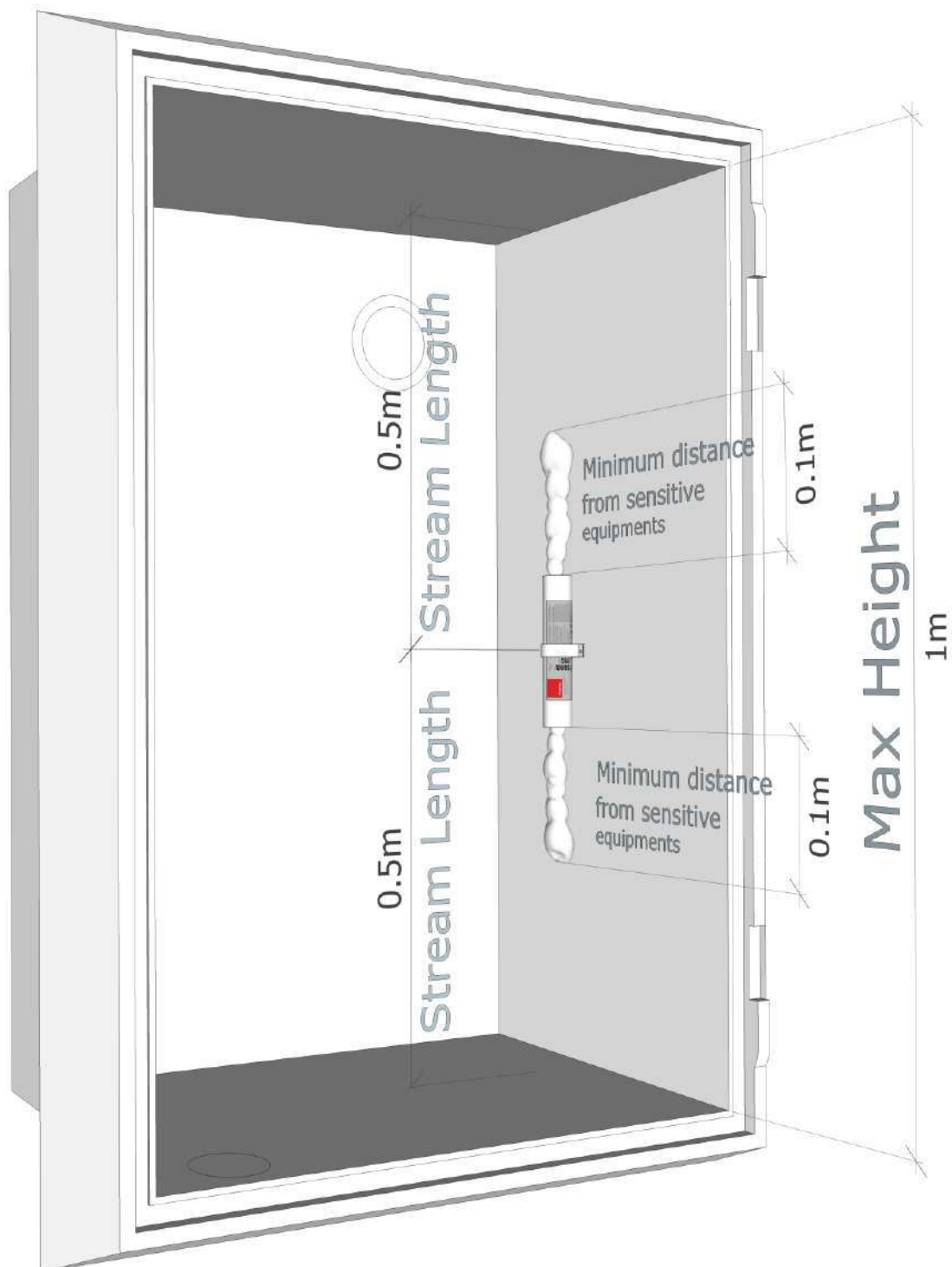

| Model: | Stream Length |
|---------|---------------|
| FP-20SE | 0.5m |

Positioning of FirePro FP-20T Generator

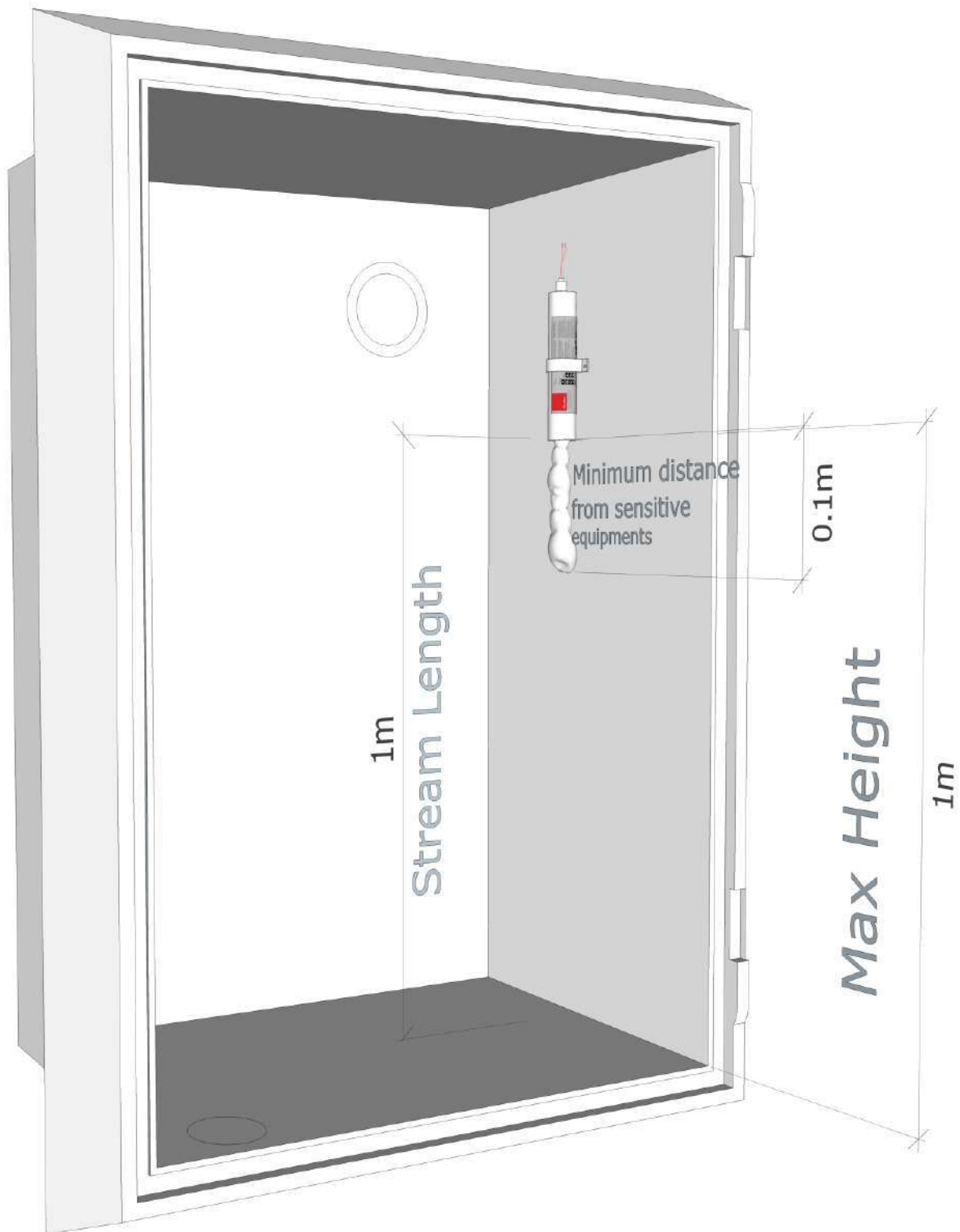

| | |
|--------|---------------|
| Model: | Stream Length |
| FP-20T | 1m |

Positioning of FirePro FP-20TH Generator

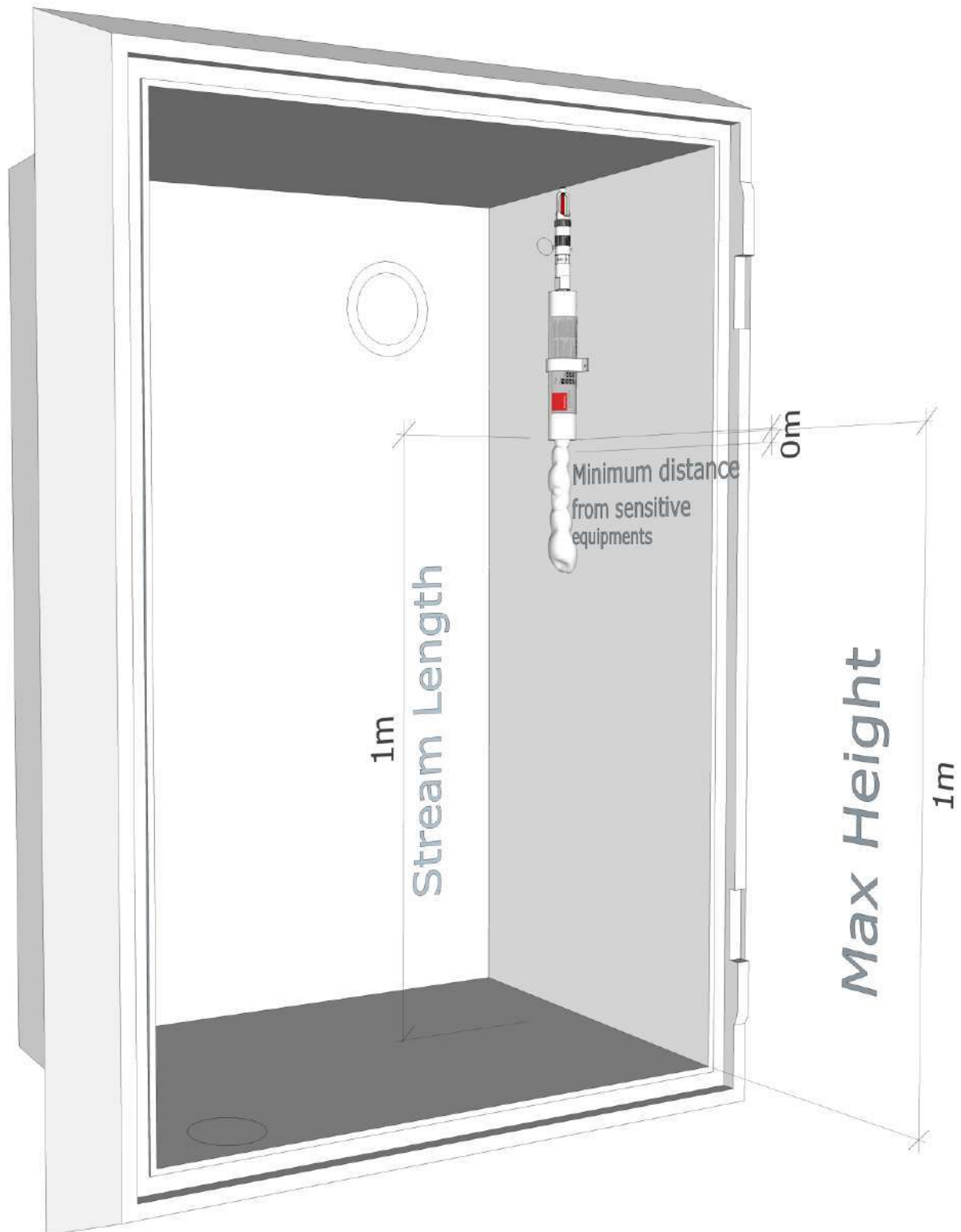

| | |
|---------|---------------|
| Model: | Stream Length |
| FP-20TH | 1m |

Positioning of FirePro FP-40S Generator

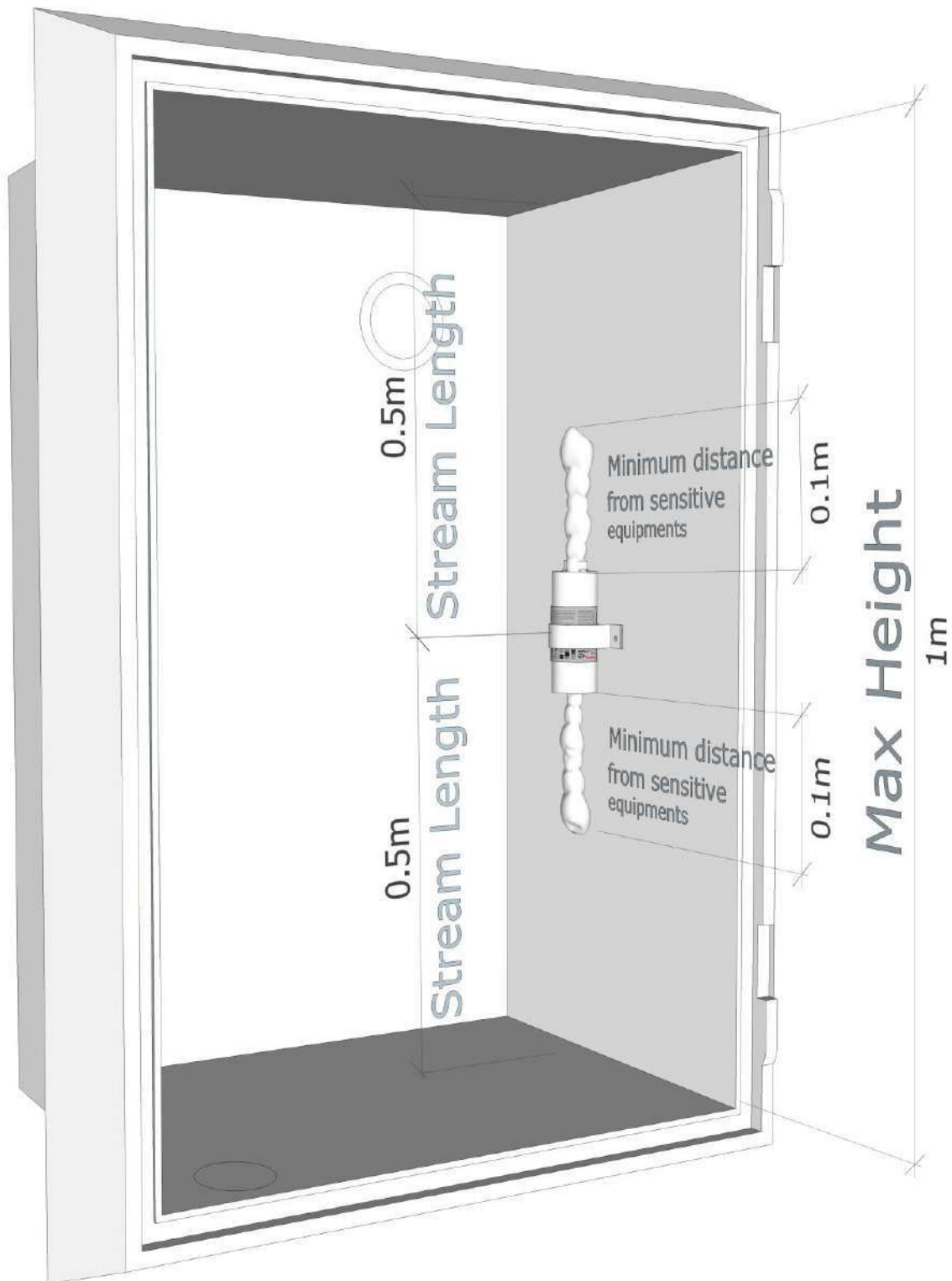

| | |
|--------|---------------|
| Model: | Stream Length |
| FP-40S | 1m |

Positioning of FirePro FP-40T Generator

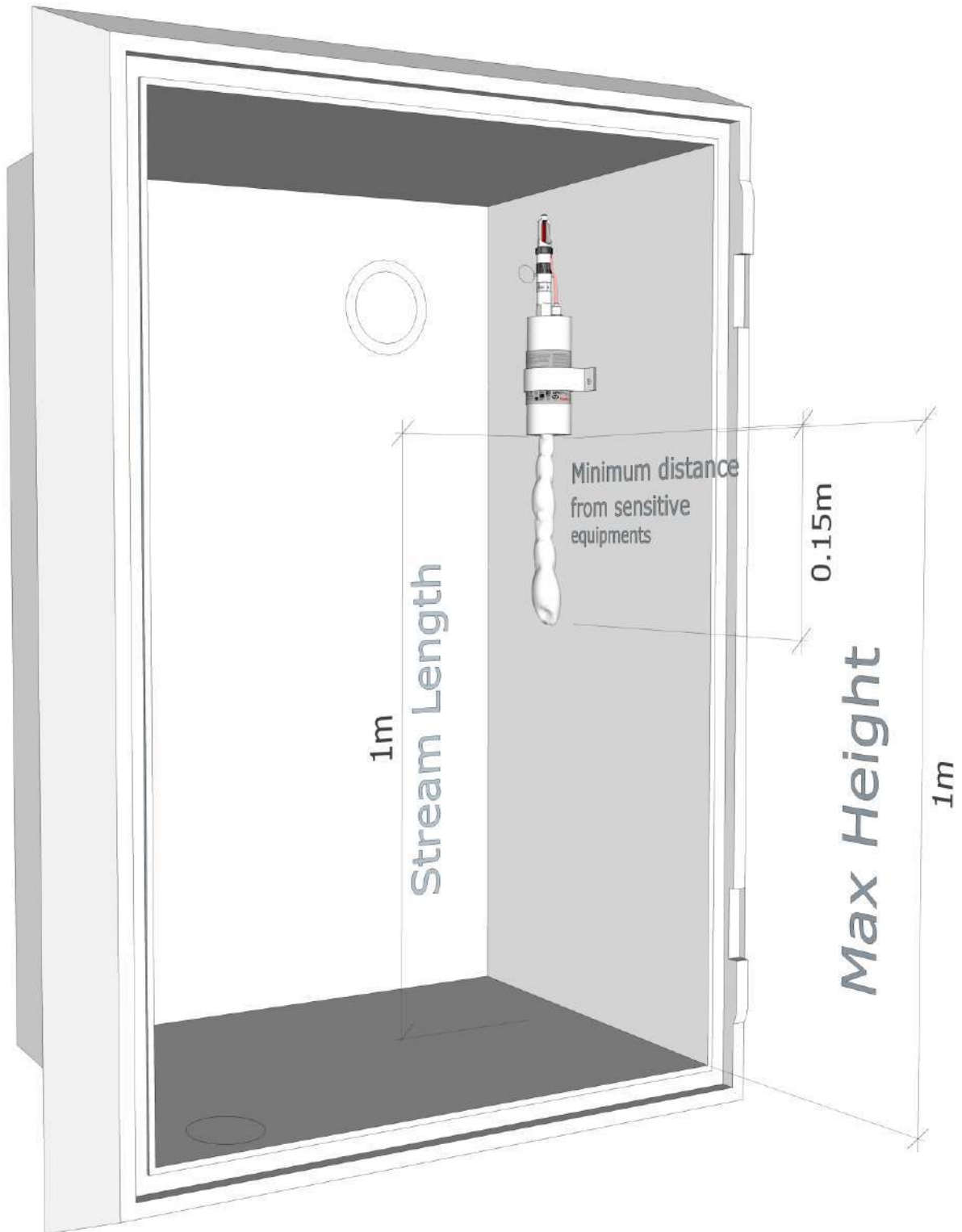

| | |
|--------|---------------|
| Model: | Stream Length |
| FP-40T | 1m |

Positioning of FirePro FP-80S Generator

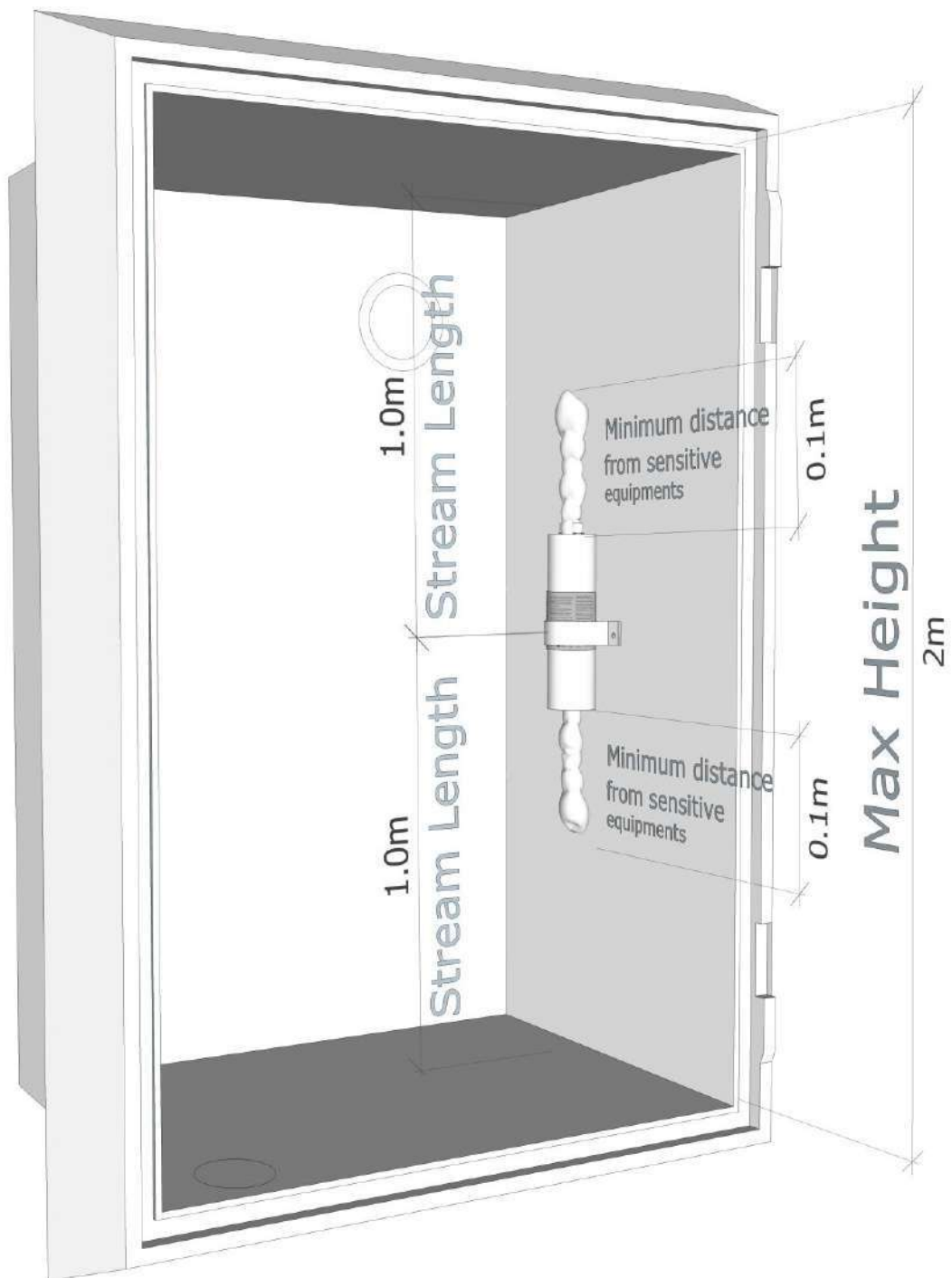

| Model: | Stream Length |
|--------|---------------|
| FP-80S | 2m |

Positioning of FirePro FP-80T Generator

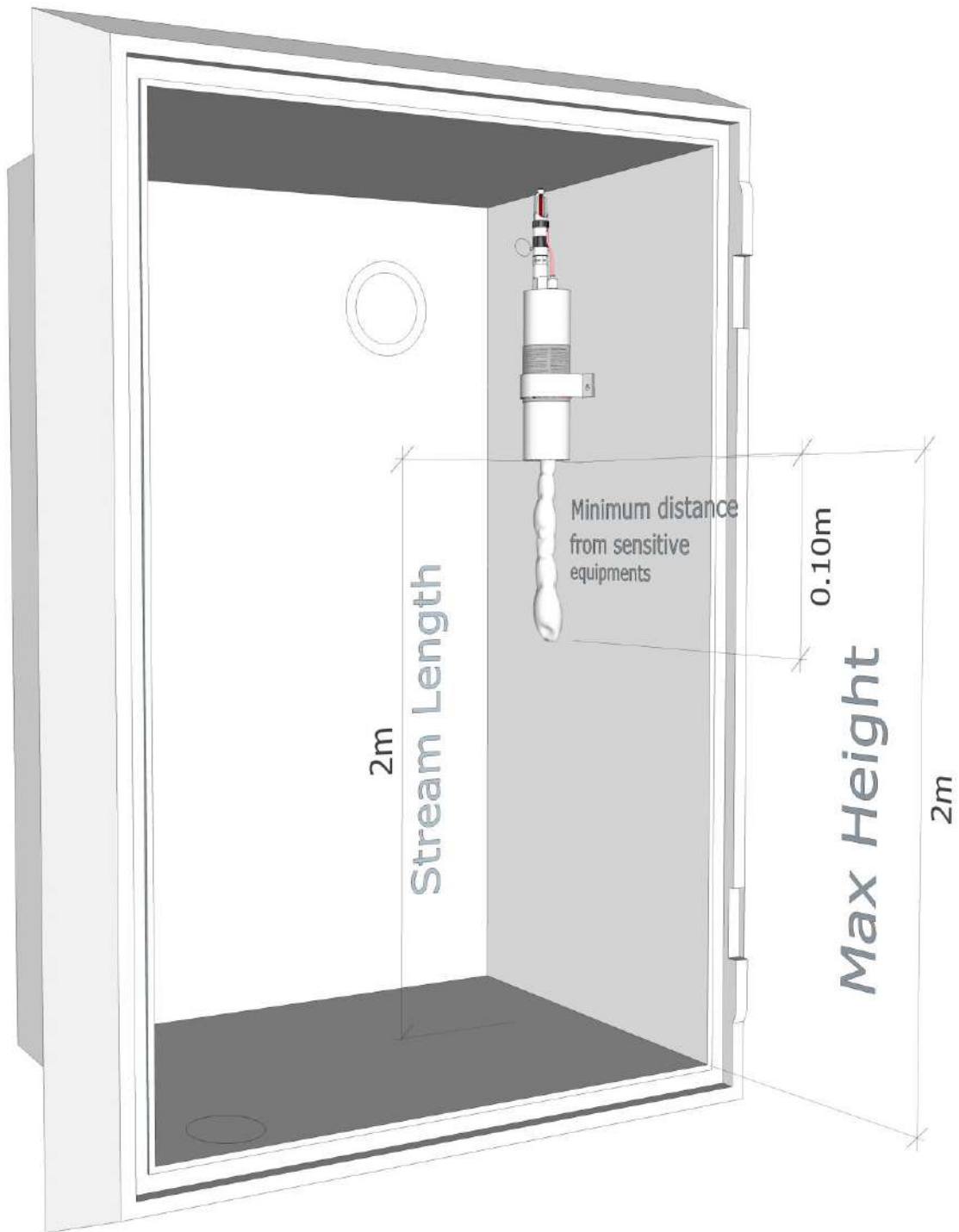

| | |
|--------|---------------|
| Model: | Stream Length |
| FP-80T | 2m |

Positioning of FirePro FP-100S Generator

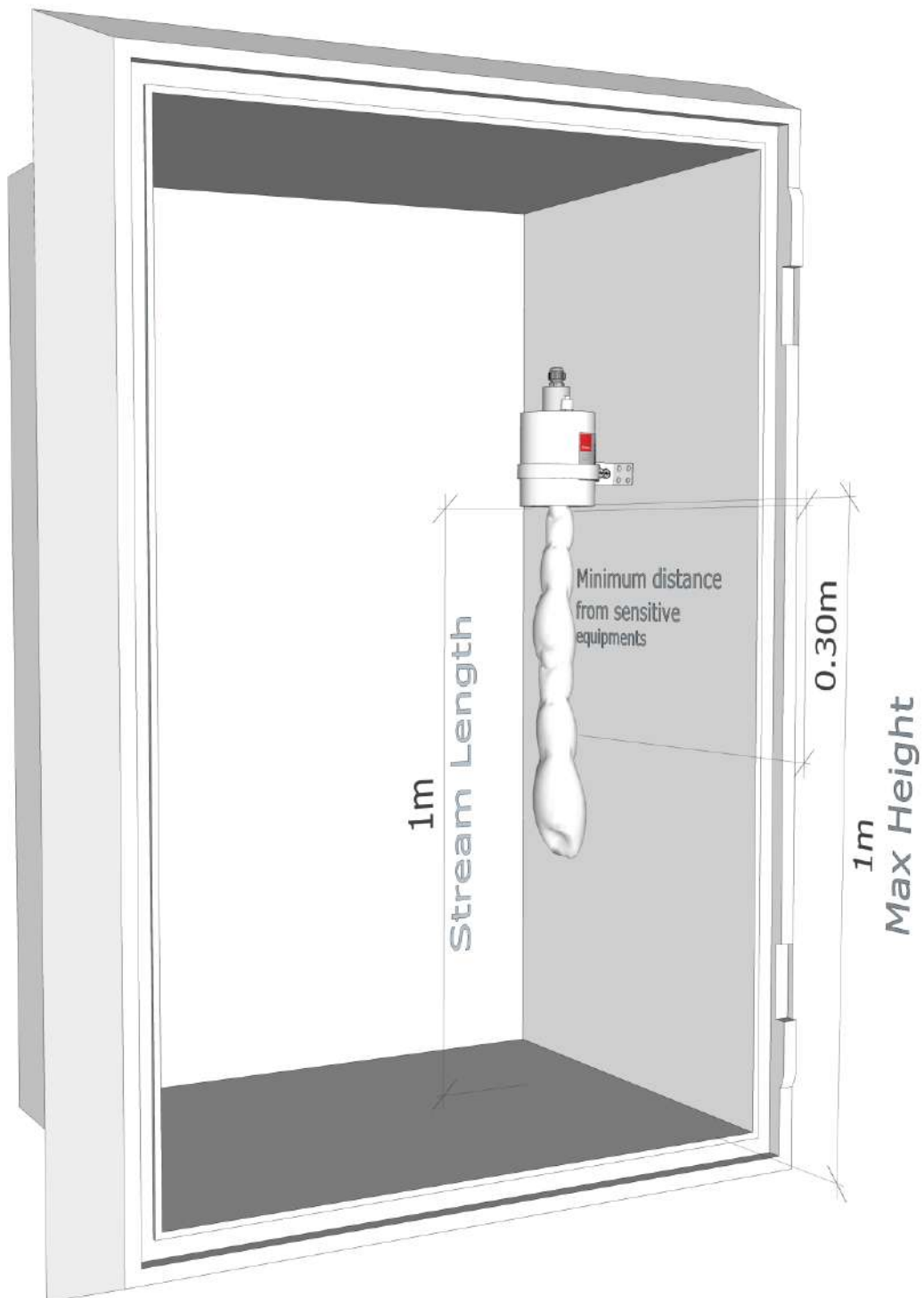

| | |
|---------|---------------|
| Model: | Stream Length |
| FP-100S | 1m |

Positioning of FirePro FP-200S Generator

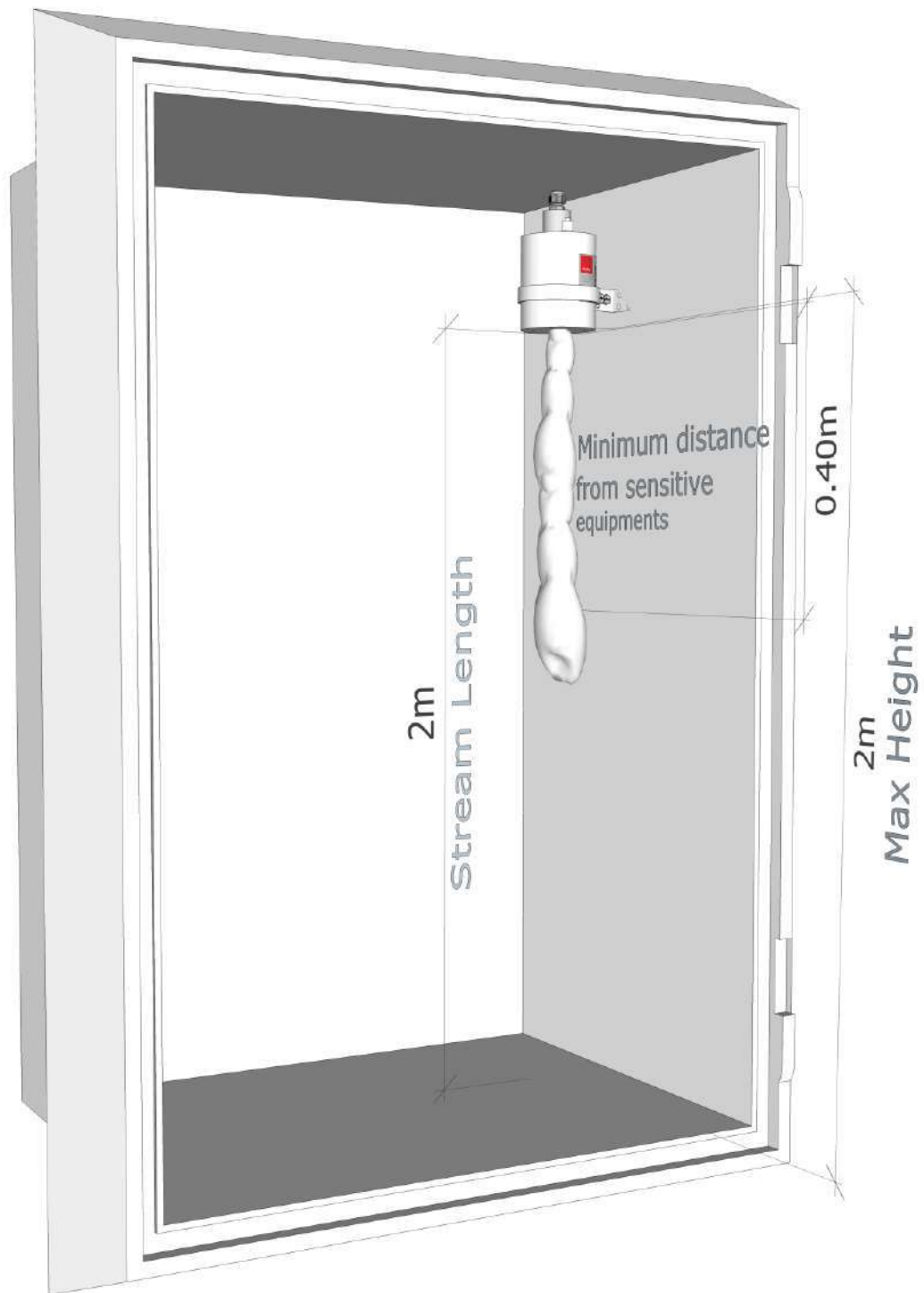

| | |
|---------|---------------|
| Model: | Stream Length |
| FP-200S | 2m |

Positioning of FirePro FP-500S Generator

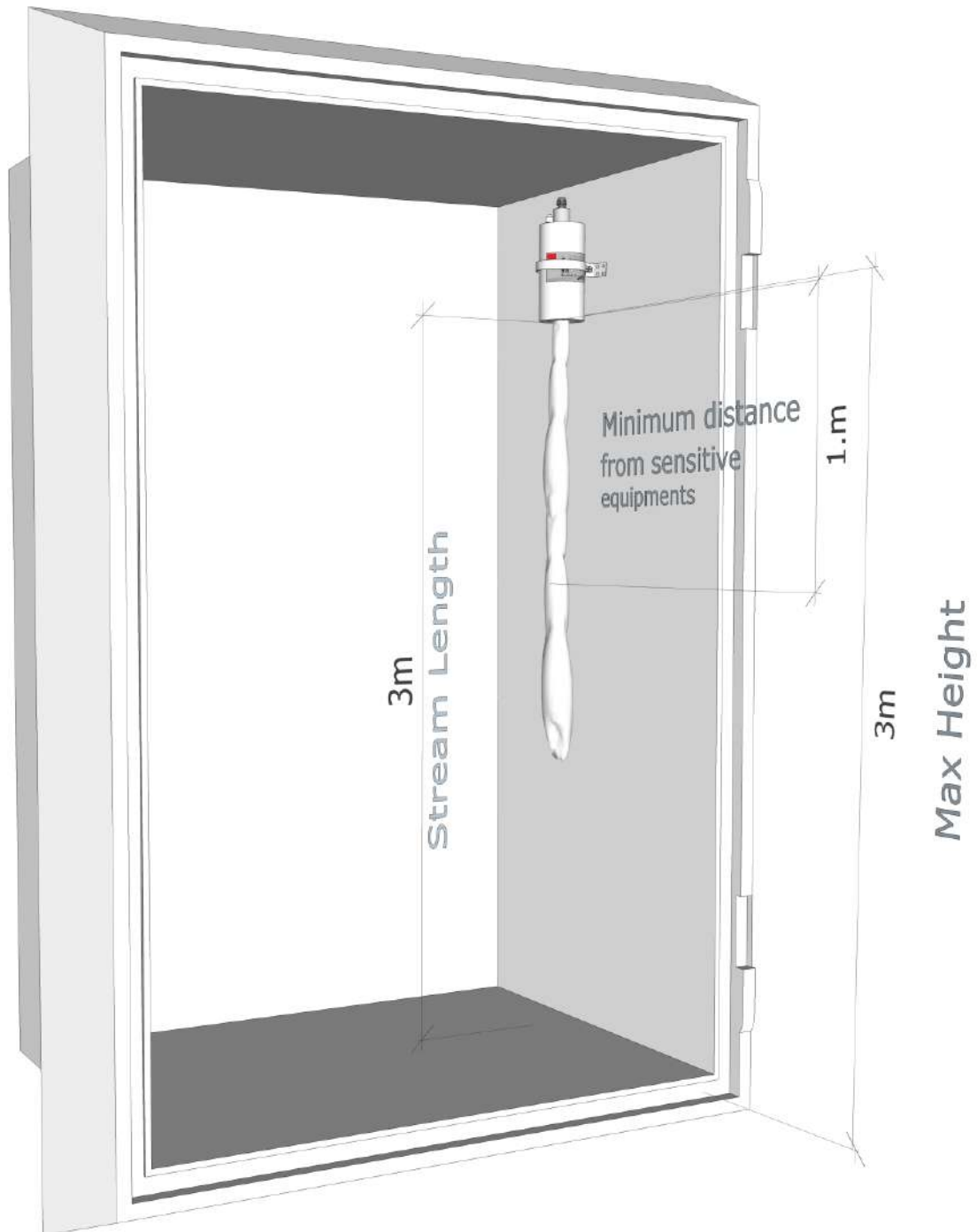

| | |
|---------|---------------|
| Model: | Stream Length |
| FP-500S | 3m |

FirePro

Appendix 4

Installation Guideline & Wiring Correction to Aerosol Generators including earthing

To be read and used in conjunction with
FirePro Information, Instruction & User
Manual Version 8, May 2020

FirePro Systems Ltd

8 Faleas Str.,CY-4101 Limassol, CYPRUS
Tel.+357 25 379999, Fax.+357 25 354432
Web:www.firepro.com, email:mail@firepro.com
An ISO 9001:2015 & ISO 14001:2015 registered company

General Installation Guide Line about the FirePro Aerosol Generators **FP-20SE/T/TH, FP-40S/T, FP-80S/T,FP-100S, FP-200S,FP-500S.**

FP-20SE/T/TH:

- Step 1:** Take the "Bracket" and place it on the aerosol generator.
- Step 2:** Align "Bracket" holes with surface material holes.
- Step 3:** Select type of screws suitable to the surface material to be fixed (these screws are not supplied with the kit).
- Step 4:** Pass the screws through the aligned holes and fix them on the surface material.
- Step 5:** The aerosol generator is ready for cable connections.

FP-40S/T, FP-80S/T:

- Step 1:** Take the "Bracket part 1" and place it on top of the aerosol generator.
- Step 2:** Take the "Bracket part 2" and place it under the aerosol generator.
- Step 3:** Align "Bracket part 1" holes with "Bracket part 2" holes.
- Step 4:** Select type of screws suitable to the surface material to be fixed (these screws are not supplied with the kit).
- Step 5:** Pass the screws through the aligned holes and fix them on the surface material.
- Step 6:** The aerosol generator is ready for cable connections.

FP-100S/200S:

- Step 1:** Pass through the Aerosol Generator the Ring Bracket.
- Step 2:** Take (L) bracket and place it inside the (Ring) bracket.
- Step 3:** Align (L) bracket holes to the (Ring) bracket holes.
- Step 4:** Pass the screws through the aligned holes and tide them with the spanner key 11,13 to the nuts. Use screw size "M8" for the longer hole and screw size "M6" for the smaller hole.
- Step 5:** Select type of screws suitable to the surface material to be fixed (these screws are not supplied with the kit).
- Step 6:** Pass the selected screws through the (L) bracket holes and fix them on the surface material.
- Step 7:** The aerosol generator is ready for cable connections.

FP-500S:

- Step 1:** Pass through the Aerosol Generator the 2 Ring Brackets.
- Step 2:** Take each (L) bracket and place it inside the (Ring) bracket.
- Step 3:** Align each (L) bracket holes to the (Ring) bracket holes.
- Step 4:** Pass the screws through the aligned holes and tide them with the spanner key 11,13 to the nuts. Use screw size "M8" for the longer hole and screw size "M6" for the smaller hole.
- Step 5:** Select type of screws suitable to the surface material to be fixed (these screws are not supplied with the kit).
- Step 6:** Pass the selected screws through the (L) bracket holes and fix them on the surface material.
- Step 7:** The aerosol generator is ready for cable connections.

Aerosol Generator FP-20SE/T/TH

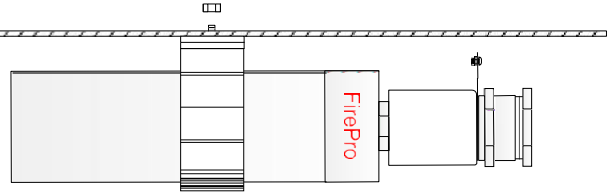
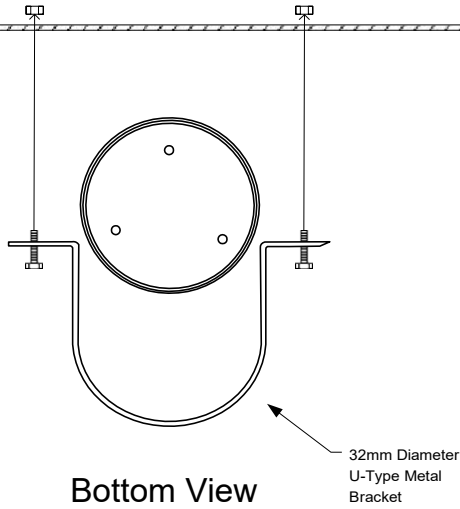

Side View

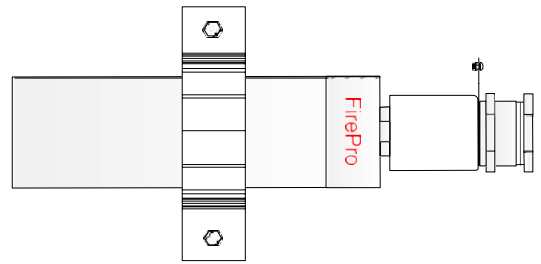

Front View

- | |
|--|
| Step 1 |
| Take the "Bracket" and place it on the aerosol generator. |
| Step 2 |
| Align "Bracket" holes with surface material holes. |
| Step 3 |
| Select type of screws suitable to the surface material to be fixed (these screws are not supplied with the kit). |
| Step 4 |
| Pass the screws through the aligned holes and fix them on the surface material. |
| Step 5 |
| The aerosol generator is ready for cable connections. |

FirePro Systems

| REV. | DESCRIPTION | DATE | BY |
|------|-----------------------------------|------------|--------------------|
| 1.0 | Generator Installation guide line | 24/06/2016 | Michaelides Loucas |

Aerosol Generator FP-40S/T

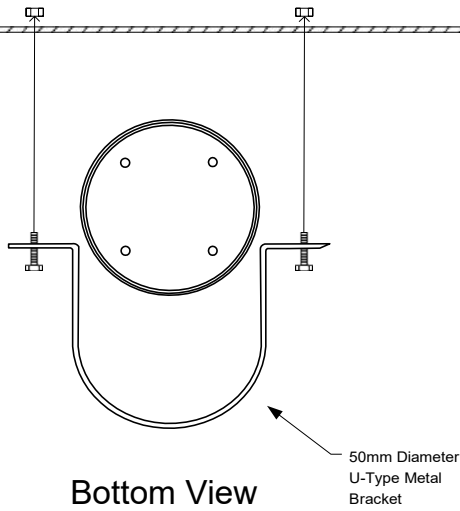

Bottom View

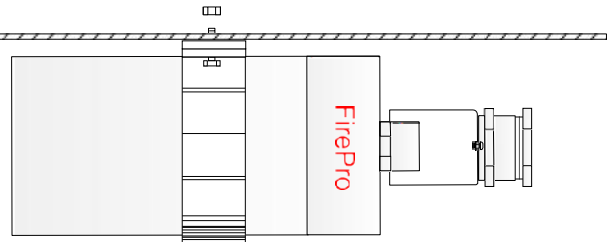

Side View

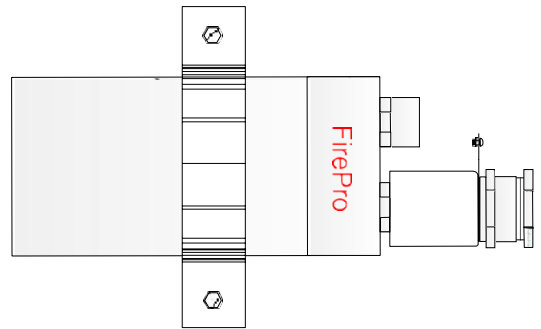

Front View

- | |
|--|
| Step 1 |
| Take the "Bracket" and place it on the aerosol generator. |
| Step 2 |
| Align "Bracket" holes with surface material holes. |
| Step 3 |
| Select type of screws suitable to the surface material to be fixed (these screws are not supplied with the kit). |
| Step 4 |
| Pass the screws through the aligned holes and fix them on the surface material. |
| Step 5 |
| The aerosol generator is ready for cable connections. |

FirePro Systems

| REV. | DESCRIPTION | DATE | BY |
|------|-----------------------------------|------------|--------------------|
| 1.0 | Generator Installation guide line | 24/06/2016 | Michaelides Loucas |

Aerosol Generator FP-80S/T

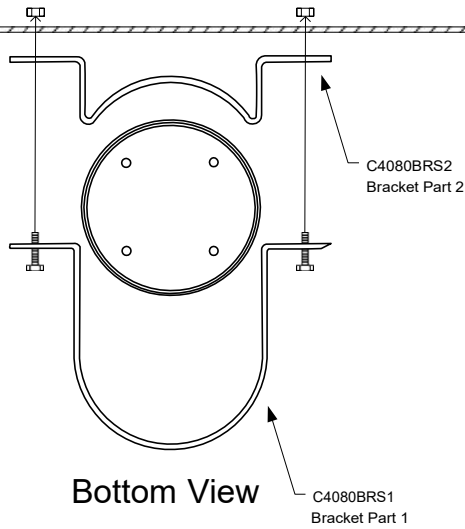

Bottom View

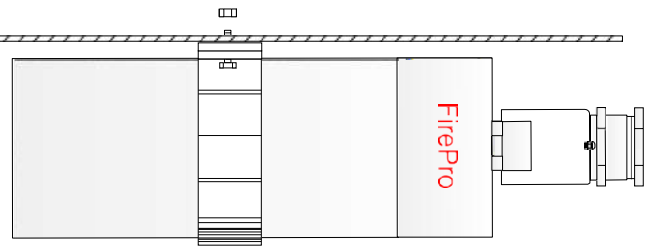

Side View

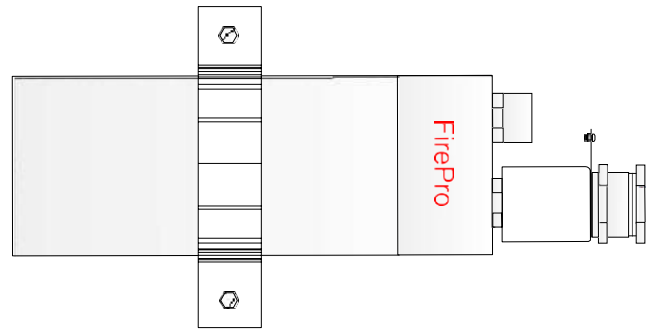

Front View

- Step 1**
Take the "Bracket part 1" and place it on top of the aerosol generator.
- Step 2**
Take the "Bracket part 2" and place it under the aerosol generator.
- Step 3**
Align "Bracket part 1" holes with "Bracket part 2" holes.
- Step 4**
Select type of screws suitable to the surface material to be fixed (these screws are not supplied with the kit).
- Step 5**
Pass the screws through the aligned holes and fix them on the surface material.
- Step 6**
The aerosol generator is ready for cable connections.

FirePro Systems

| REV. | DESCRIPTION | DATE | BY |
|------|-----------------------------------|------------|--------------------|
| 1.0 | Generator Installation guide line | 24/06/2016 | Michaelides Loucas |

Aerosol Generator FP-100S & FP-200S

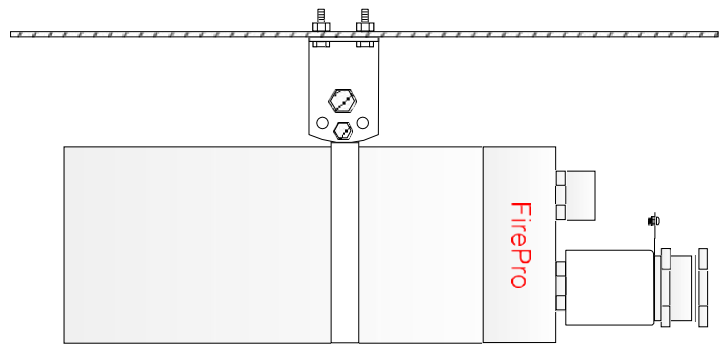
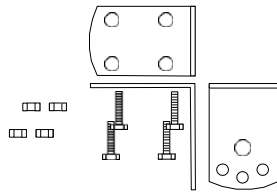
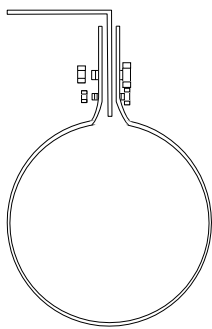

- Step 1**
Pass through the Aerosol Generator the Ring Bracket
- Step 2**
Take (L) bracket and place it inside the (Ring) bracket.
- Step 3**
Align (L) bracket holes to the (Ring) bracket holes.
- Step 4**
Pass the screws through the aligned holes and tide them with the spanner key 11,13 to the nuts. Use screw size "M8" for the longer hole and screw size "M6" for the smaller hole.
- Step 5**
Select type of screws suitable to the surface material to be fixed (these screws are not supplied with the kit).
- Step 6**
Pass the selected screws through the (L) bracket holes and fix them on the surface material.
- Step 7**
The aerosol generator is ready for cable connections.

| FirePro Systems | | | |
|-----------------|-----------------------------------|------------|--------------------|
| REV. | DESCRIPTION | DATE | BY |
| 1.0 | Generator Installation guide line | 24/06/2016 | Michaelides Loucas |

Aerosol Generator FP-500S

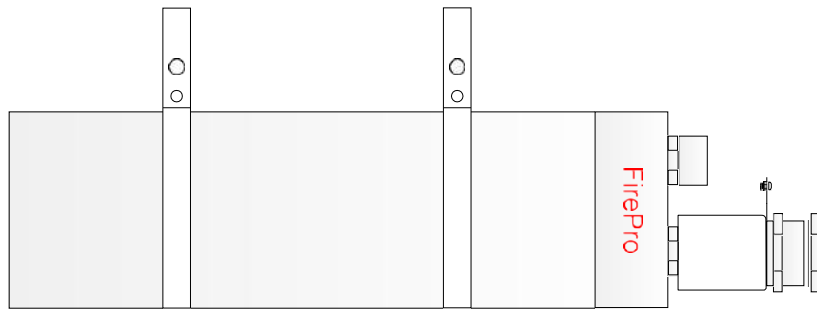
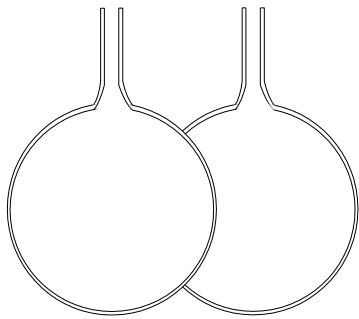

Step 1
Pass through the Aerosol Generator the 2 Ring Brackets

| FirePro Systems | | | |
|-----------------|-----------------------------------|------------|--------------------|
| REV. | DESCRIPTION | DATE | BY |
| 1.0 | Generator Installation guide line | 24/06/2016 | Michaelides Loucas |



Aerosol Generator FP-500S

4 3 2 1

D

C

B

A

D

C

B

A

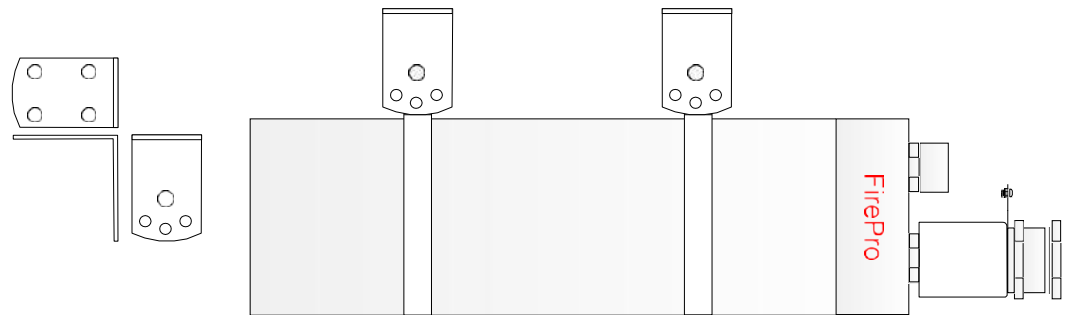

Step 2
Take each (L) bracket and place it inside the (Ring) bracket.

Step 3
Align each (L) bracket holes to the (Ring) bracket holes.

| FirePro Systems | | | |
|-----------------|-----------------------------------|------------|--------------------|
| REV. | DESCRIPTION | DATE | BY |
| 1.0 | Generator Installation guide line | 24/06/2016 | Michaelides Loucas |

4 3 2 1 Page 7

Aerosol Generator FP-500S

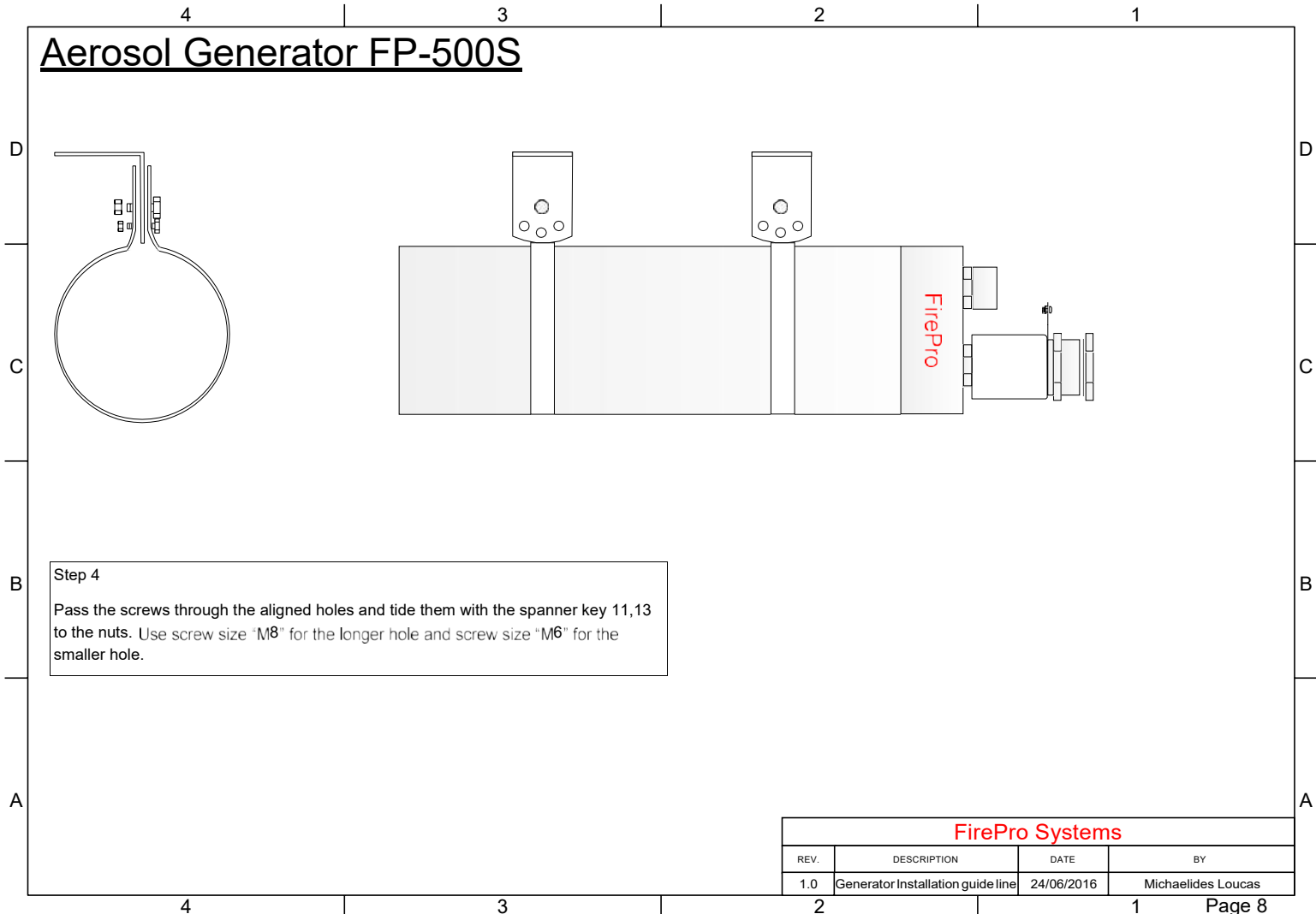

Step 4
 Pass the screws through the aligned holes and tide them with the spanner key 11,13 to the nuts. Use screw size "M8" for the longer hole and screw size "M6" for the smaller hole.

| FirePro Systems | | | |
|-----------------|-----------------------------------|------------|--------------------|
| REV. | DESCRIPTION | DATE | BY |
| 1.0 | Generator Installation guide line | 24/06/2016 | Michaelides Loucas |

Aerosol Generator FP-500S

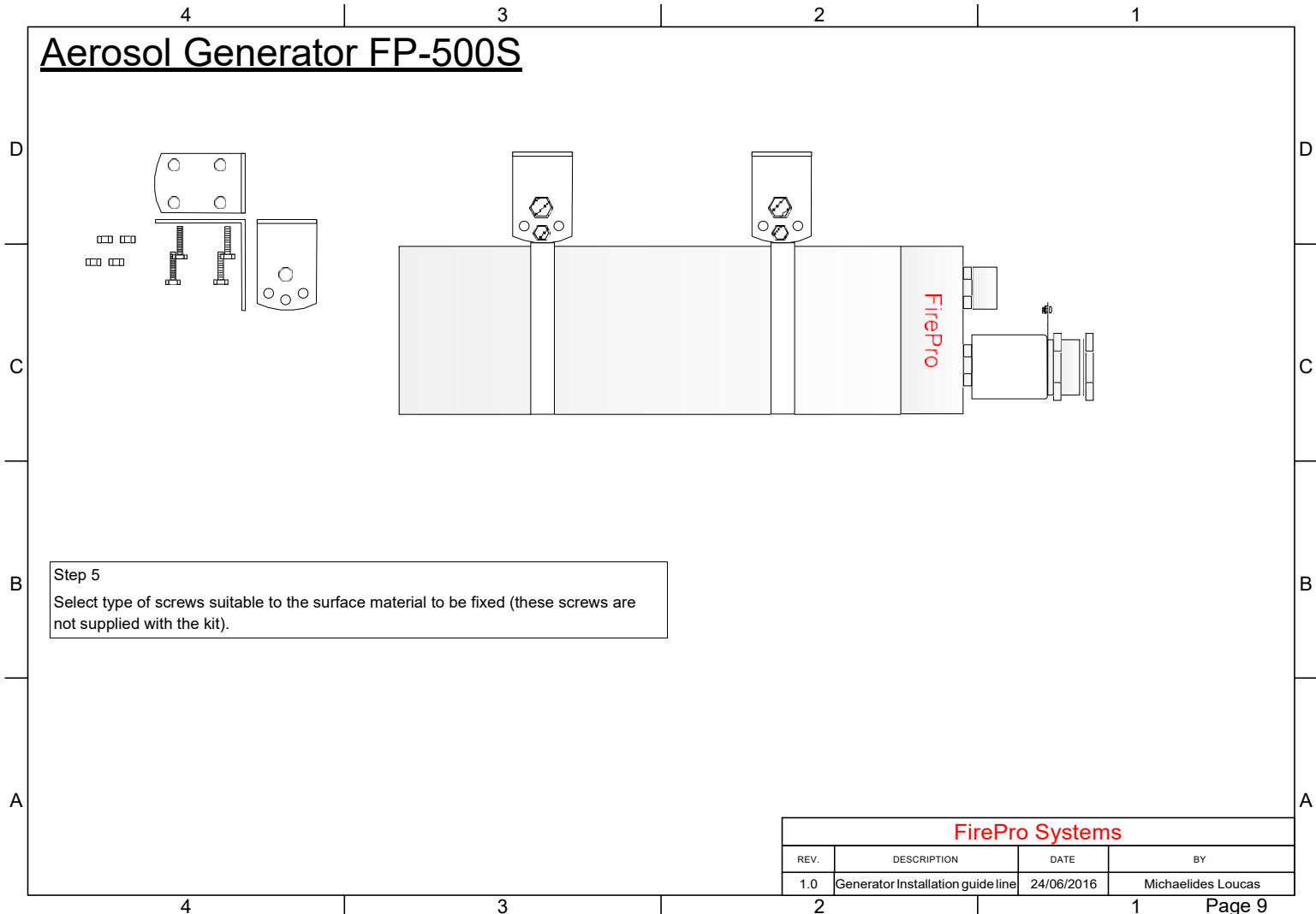

Step 5
 Select type of screws suitable to the surface material to be fixed (these screws are not supplied with the kit).

| FirePro Systems | | | |
|-----------------|-----------------------------------|------------|--------------------|
| REV. | DESCRIPTION | DATE | BY |
| 1.0 | Generator Installation guide line | 24/06/2016 | Michaelides Loucas |

Aerosol Generator FP-500S

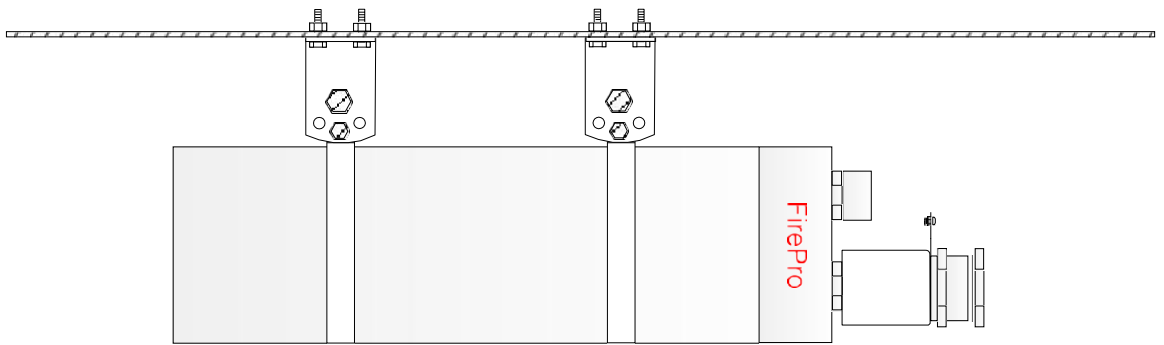

Step 6
Pass the selected screws through the (L) bracket holes and fix them on the surface material.

Step 7
The aerosol generator is ready for cable connections.

FirePro Systems

| REV. | DESCRIPTION | DATE | BY |
|------|-----------------------------------|------------|--------------------|
| 1.0 | Generator Installation guide line | 24/06/2016 | Michaelides Loucas |

Earthing / Grounding details:

Multiple grounds throughout an installation could result in a difference of potential between Condensed Aerosol Generators and possibly could also create ground fault problems to the Fire Extinguishing Panel. Use of local bonding to earth (grounding) of the Condensed Aerosol Generator metallic enclosure could be beneficial for the following reasons, such as:

- Lightning Protection
- Protection against voltage surges
- Provision of "clean earth" system
- Shielding against electromagnetic interference noise
- Protection against electrostatic discharge

However, the above benefits would be effective only in case the bonding/grounding is done properly. It is advised that the bonding / grounding of the Condensed Aerosol Generator metallic enclosure is done locally, and individually from the braid of the cable. The cable braid should be grounded at the common earthing terminal within the Fire Alarm and Extinguishing Panel side only.

Interconnected cable screens:

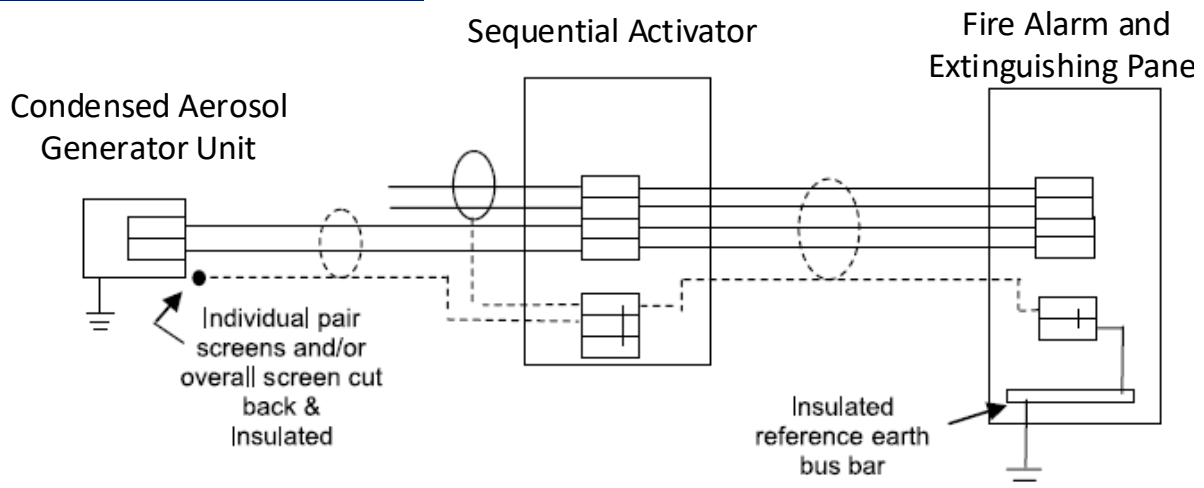

Local Bonding to Earth (Ground) of Aerosol Generator:

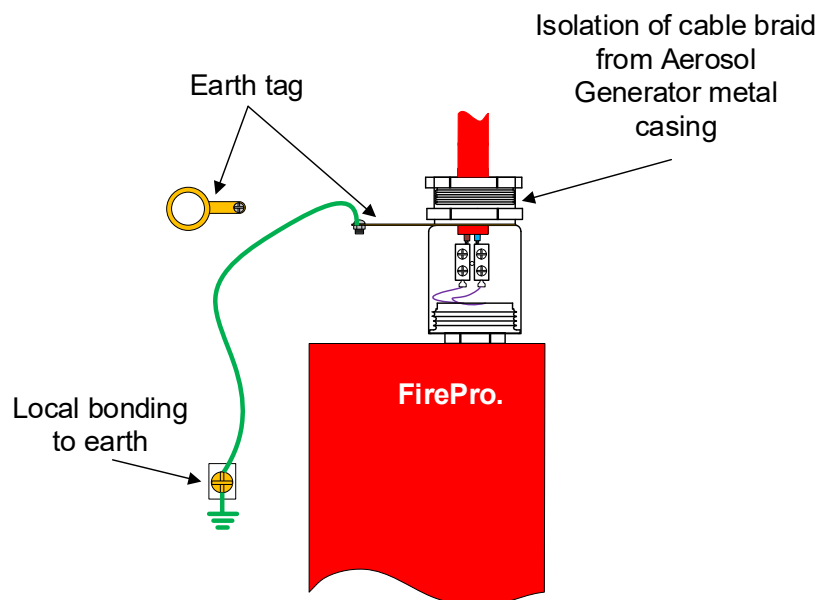

Insulation of cable braid on Condensed Aerosol Generator Unit side:

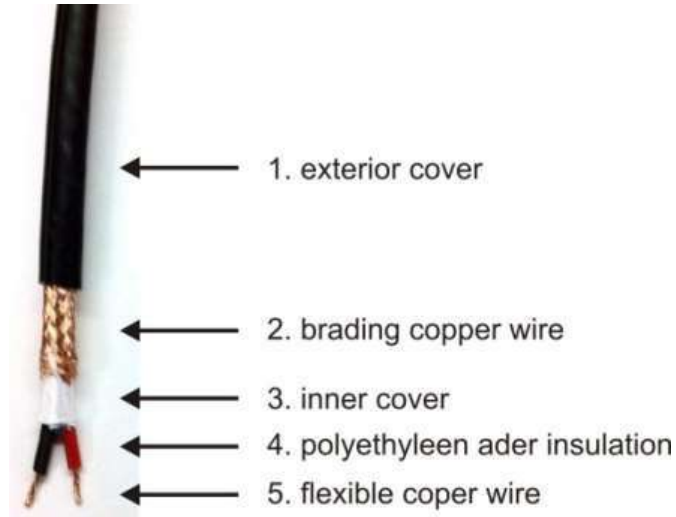

illustration 1



illustration 2



illustration 3

- Coiling up or looping a cable creates an induction coil. Laying / installing the cable in straight lines aids to prevent this.
- When cutting the cable, it is important not to cut into the insulation in order to prevent current leakage.
- When leading a cable through a swivel (illustrations 2 & 3), it is important that the braid, jacket and/or flexible copper wire (illustration 1) do not come in contact with the (metal) swivel.
- Any bare wires should be properly protected and cannot come into contact with the casing and/or other wiring

FirePro

Appendix 5

LARGE GENERATORS INSTALLATION GUIDELINES

FP-1200, FP-2000, FP-3000, FP-4200, FP-5700

**To be read and used in conjunction with
FirePro Information, Instruction & User
Manual Version 8, May 2020**

FirePro Systems Ltd

8 Faleas Str.,CY-4101 Limassol, CYPRUS
Tel.+357 25 379999, Fax.+357 25 354432
Web:www.firepro.com, email:mail@firepro.com
An ISO 9001:2015 & ISO 14001:2015 registered company

Installation Guidelines

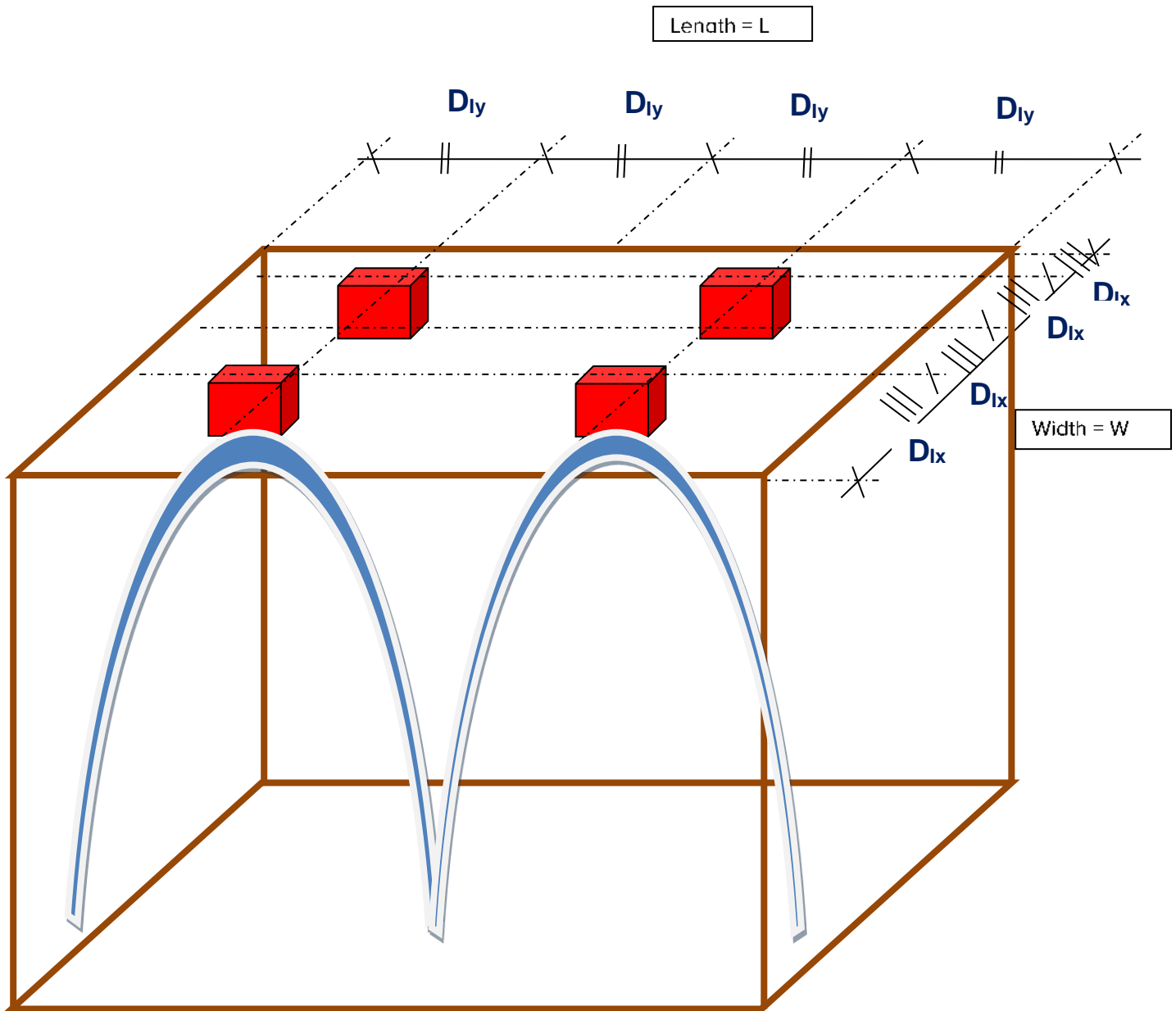

D_r : Installation Distance

D_{lx} & D_{ly} : Installation Coordinates:

N_G : Number of Generators to be installed/spaced along the subject side

$D_{lx} = W/2*N_G$ And, $D_{ly} = L/2*N_G$

For Ex.: if $L = 6m$ & $W = 4m$

then, $D_{lx} = 4 / (2*2) = 4/4 = 1.0m$, & $D_{ly} = 6 / (2*2) = 1.5m$

Installation Clearance - the Do's & Dont's

Wrong Installation

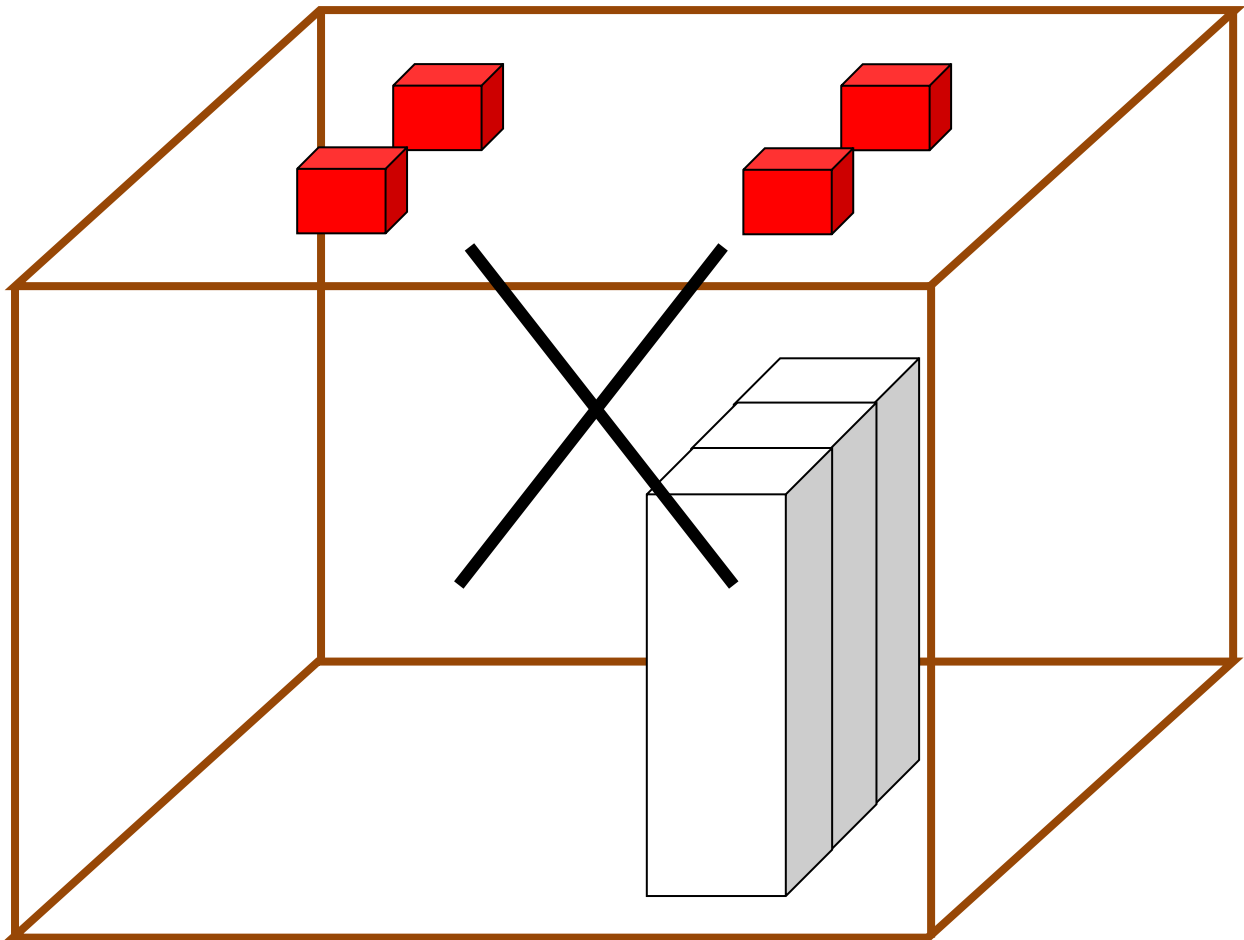

Proper Installation

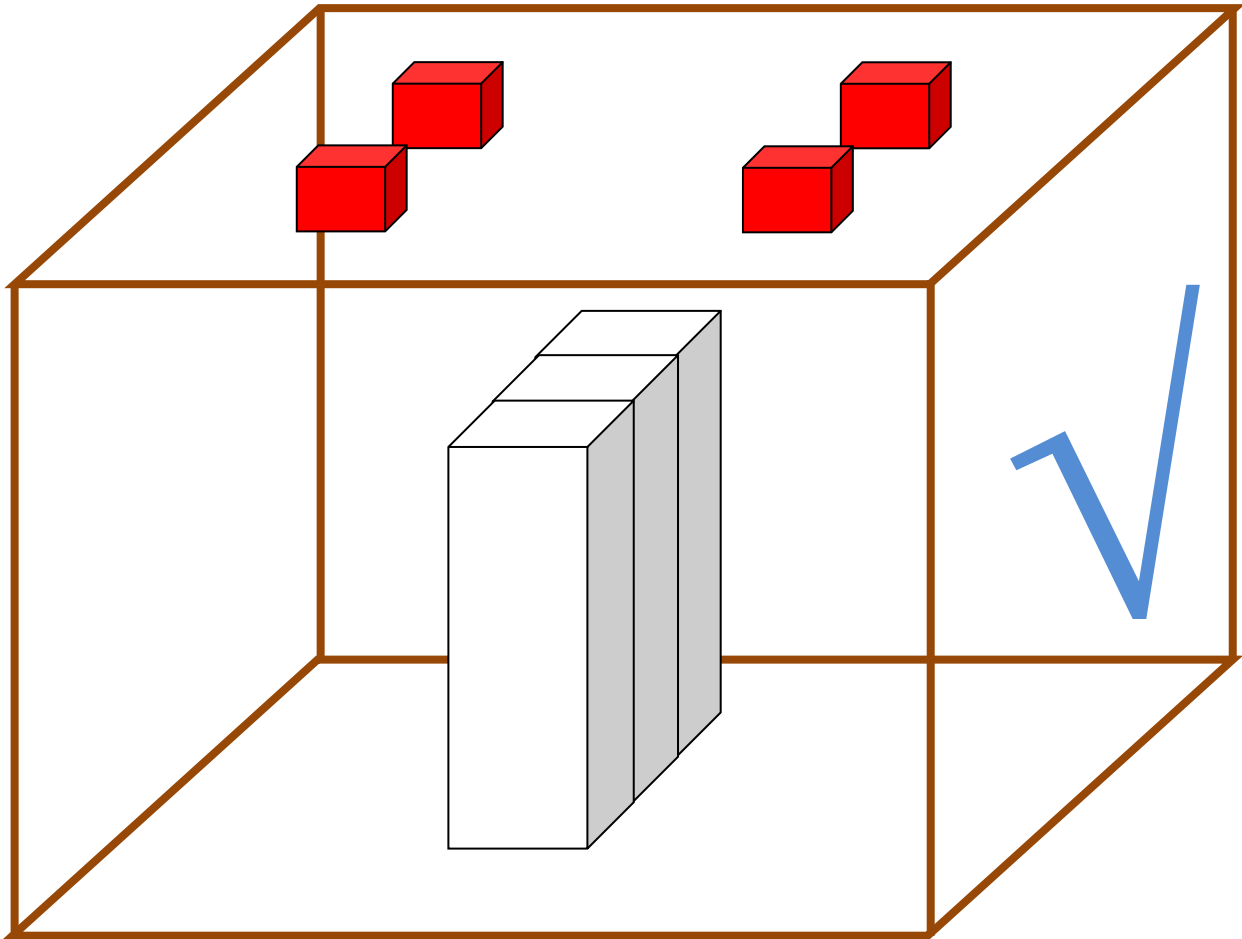

FirePro

Appendix 6

To be read and used in conjunction
with FirePro Information, Instruction &
User Manual Version 8, May 2020

Fire Suppression System

Log Book

For control panel, Sequential Activators and
FirePro Condensed Aerosol Generators
as per System Design

Keep Readily Available For Inspection

Protect logbook by storing it in a safe place next to the Fire Extinguishing Panel and a copy into a safety box.

CONTENTS OF LOG BOOK

| | | |
|------------|---|-------|
| 1.0 | Introduction | 3 |
| 2.0 | General data | 4 |
| | Useful Telephone Contacts | 4 |
| | I have read this document and understand its contents | 4 |
| 3.0 | Equipment in use Fire Suppression System Design | 5 |
| | Fire Control Panel & Accessories – System Design | 5 |
| | FirePro Condensed Aerosol Generators – System Design | 6 |
| 4.0 | Engineering drawings | 7 |
| 5.0 | Commissioning of the Fire Suppression Condensed AEROSOL System | 8 |
| 5.1 | Commissioning of the Fire Extinguishant Panel | 8 |
| 5.2 | Commissioning KENTEC Sequential Activator – Aerosol Generator | 8 |
| 5.3 | Commissioning and test procedures by Service Expert | 10 |
| 6.0 | Management by user | 10 |
| 6.1 | Manager (Trained Person) | 10 |
| 6.2 | Periodically checks and precautionary maintenance by trained person | 11 |
| | Daily check | 11 |
| | Monthly check | 13 |
| | After delivery & after servicing check | 13 |
| 6.3 | Periodically checks and precautionary maintenance by Service Expert | 13 |
| 7.0 | History Log | 15-16 |
| 8.0 | Certification | 17 |

1.0 INTRODUCTION

This fire suppression system must be inspected, tested, maintained every year.

All events related to the fire suppression system need to be recorded without exception in this logbook, e.g. fire extinguishant alarms, failures, checks, repairs and changes made. This procedure provides a continuous documentation concerning the actual status as well as the operation condition of the fire suppression system. We would therefore advise you to record every event, and particularly the periodical checks, in this logbook upon occurrence and/or completion. The only people authorized to make entries into the logbook are the manager (Trained Person), the contractor or his maintenance expert (ME).

Failures that cannot be solved immediately need to be reported to the contractor at once.

In case performance requirements regarding 'real fire alarm', 'undesired fire notification' or 'false fire notification' are listed in the Operational Requirements, this must be reported in this logbook.

During the yearly check, the manager (trained person) and the maintenance expert will use this statistic to evaluate the performance of the operational requirements and take action if necessary.

2.0 GENERAL DATA

Useful Project Details

Project number.....

Date of completion:[...../...../.....].....

Building.....

Address of premises.....

.....

Owner / Manager.....

Dealer.....

Fire Detection Company.....

Contractor.....

Maintenance:....[Y/N]....Serial# [.....].....Date:[...../...../.....].....

Trained Person.....

Relay alarm fire.....

Location of log book.....

Useful Telephone Contacts

In Emergency Dial.....

Fire Safety Department.....

Emergency Service Control Room.....

Fire Safety Officer.....

Fire Extinguisher – Repairs.....

Fire Alarm – Repairs.....

Building Maintenance.....

I have read this document and understand its contents

Owner / Manager...[Name].....[.....]

Owner / Manager...[Signature].....[.....]

Date: [...../...../.....]

3.0 EQUIPMENT IN USE - FIRE SUPPRESSION SYSTEM DESIGN

FIRE CONTROL PANEL & ACCESSORIES – SYSTEM DESIGN

| | Brand | Model | Quantity | Location |
|------------------------------------|-------|-------|----------|----------|
| Ext. Control Panel | | | | |
| Backup Batteries | | | | |
| Smoke Detector | | | | |
| Heat Detector | | | | |
| Flame Detector | | | | |
| Linear Heat Detector | | | | |
| Isolation Switch / Abort Button | | | | |
| Gas Release MCP | | | | |
| Bell | | | | |
| Siren and Strobe | | | | |
| Gas Release Sign | | | | |
| Auto Dialler | | | | |
| External Power supply | | | | |
| Backup Batteries | | | | |

FirePro CONDENSED AEROSOL GENERATORS – SYSTEM DESIGN

| Generator | ID | Location | Type (*) | Location | Seq.Activator | ID |
|-----------|----|----------|----------|----------|---------------|------|
| Generator | 01 | | | | Sequential | A 01 |
| Generator | 02 | | | | Activator | B 02 |
| Generator | 03 | | | | Sequential | A 03 |
| Generator | 04 | | | | Activator | B 04 |
| Generator | 05 | | | | Sequential | A 05 |
| Generator | 06 | | | | Activator | B 06 |
| Generator | 07 | | | | Sequential | A 07 |
| Generator | 08 | | | | Activator | B 08 |
| Generator | 09 | | | | Sequential | A 09 |
| Generator | 10 | | | | Activator | B 10 |
| Generator | 11 | | | | Sequential | A 11 |
| Generator | 12 | | | | Activator | B 12 |
| Generator | 13 | | | | Sequential | A 13 |
| Generator | 14 | | | | Activator | B 14 |
| Generator | 15 | | | | Sequential | A 15 |
| Generator | 16 | | | | Activator | B 16 |
| Generator | 17 | | | | Sequential | A 17 |
| Generator | 18 | | | | Activator | B 18 |
| Generator | 19 | | | | Sequential | A 19 |
| Generator | 20 | | | | Activator | B 20 |
| Generator | 21 | | | | Sequential | A 21 |
| Generator | 22 | | | | Activator | B 22 |
| Generator | 23 | | | | Sequential | A 23 |
| Generator | 24 | | | | Activator | B 24 |
| Generator | 25 | | | | Sequential | A 25 |
| Generator | 26 | | | | Activator | B 26 |
| Generator | 27 | | | | Sequential | A 27 |
| Generator | 28 | | | | Activator | B 28 |
| Generator | 29 | | | | Sequential | A 29 |
| Generator | 30 | | | | Activator | B 30 |
| Generator | 31 | | | | Sequential | A 31 |
| Generator | 32 | | | | Activator | B 32 |
| Generator | 33 | | | | Sequential | A 33 |
| Generator | 34 | | | | Activator | B 34 |
| Generator | 35 | | | | Sequential | A 35 |
| Generator | 36 | | | | Activator | B 36 |
| Generator | 37 | | | | Sequential | A 37 |
| Generator | 38 | | | | Activator | B 38 |
| Generator | 39 | | | | Sequential | A 39 |
| Generator | 40 | | | | Activator | B 40 |

4.0 ENGINEERING DRAWINGS

In this section insert engineering drawings and large sketches. Must be noted in the below list by reference: number, title, date and short description of what the drawing portrays.

| S/N | Reference number | Date | Title | Short description |
|-----|------------------|------|-------|-------------------|
| 1 | | | | |
| 2 | | | | |
| 3 | | | | |
| 4 | | | | |
| 5 | | | | |

5.0 COMMISSIONING OF THE FIRE SUPPRESSION CONDENSED AEROSOL SYSTEM

This method statement is applicable for the FirePro Total Flooding Condensed Aerosol Fire Suppression System

5.1 COMMISSIONING OF THE FIRE CONTROL PANEL

5.1.1

Before applying power to the Fire Extinguishant control panel, the extinguishant device (FirePro Sequential Activators / FirePro Condensed Aerosol Generators) must be physically isolated from the system by disconnecting all four wires. This will prevent any accidental activation of the Fire Condensed Aerosol Generators.

5.1.2

When electrical power is applied to the Fire Extinguishant control panel, if all connections are correct, only the green Power On and either the Automatic and Manual or Manual Only indicators should be lit. If any fault indicators are lit the wiring to the appropriate input or output should be checked and all faults cleared before proceeding.

5.1.3

Once the Fire Extinguishant control panel is fault free, it can be configured with the desired options as described in "Programming and operation" of the FirePro control panel Installation and Operation manual, provided as part of the documentation.

5.1.4

Once the Fire Extinguishant control panel has been configured the system should be thoroughly tested to ensure that the Fire control panel responds as expected and required.

5.1.5

After satisfactory testing, all final connections circuit continuity should be verified (no fault on the Extinguishing Line)

5.1.6

A record of the configuration options that have been set should be recorded.

5.2 COMMISSIONING - SEQUENTIAL ACTIVATORS – CONDENSED AEROSOL GENERATORS

To confirm that the wiring to sequential activators is correct, 24V simulation lamps (or similar as per Fire Extinguishant control panel requirements) can be fitted in place of the Condensed Aerosol Generators and the Fire Extinguishant control panel activated to ensure that all simulation lamps light when the release signal is sent.

Note: if all the simulation lamps are removed and replaced with the Condensed Aerosol Generators at once it will not be possible to diagnose connection faults if they exist.

If the circuit has been set up using simulation lamps it should be re-set once all FirePro® Condensed Aerosol Generators have been fitted.

FirePro Condensed Aerosol Generators must be connected via FirePro sequential activators. Each sequential activator can have 2 Condensed Aerosol Generators connected to it and up to 20 sequential activators in total can be connected to the Fire Extinguishant control panel. Connect FirePro Sequential Activators to the FirePro® Fire Extinguishant control panel only.

Each FirePro Sequential Activator introduces a nominal delay gap of 0.45 seconds before the next Sequential Activator in line is operated. Each Sequential Activator triggers for 2.25 sec (in total) the two Condensed Aerosol Generators that can be connected to it. Both time factors must be considered when setting the Extinguishant Duration time for the system. It is thereby recommended to set the Fire Extinguishant control panel Extinguishant Duration time to 60sec, minimum, when all 40 x Condensed Aerosol Generators are connected to the panel (e.g. 20 x S.A. – 40 x Aerosol Generators).

Even if a much smaller number of Condensed Aerosol Generators is connected to the Fire Extinguishant control panel the same Extinguishant Duration time may be used so that enough time is allowed for all Condensed Aerosol Generators to be activated.

The approximate maximum length of FP200 fire rated cable or equivalent allowed to be installed on the extinguishing output/line shall be as follows:

| | | |
|-----------------------------|-----------------------------|-----------------------------|
| 1.0 mm ² - 190 m | 1.5 mm ² - 270 m | 2.5 mm ² – 470 m |
|-----------------------------|-----------------------------|-----------------------------|

Above figures/lengths provided are indicative only. Proper calculation of the total resistance of the extinguishing line should be calculated, taking into consideration all contributing factors prior to deciding on the cable size to be used and max length allowed.

5.3 COMMISSIONING TEST PROCEDURES BY SERVICE EXPERT

| Note: It is important that operations for testing do not result in unwanted situations. Before start please do the followings:-Ensure that the system will not activate the Condensed Aerosol Generators (PHYSICALLY ISOLATE CONDENSED AEROSOL GENERATORS) | | |
|---|---|----------|
| | Notes | Comments |
| 1 | Physically isolate Sequential Activators / Condensed Aerosol Generators from the system. | |
| 2 | Power the system. Correct any faults before processing. | |
| 3 | Ensure that the Fire Extinguishant control panel responds as expected. | |
| 4 | Connect to the system (1) Sequential Activators. | |
| 5 | Remove the end of line component from the Fire Extinguishant control panel. Connect it to the last Sequential Activator. | |
| 6 | Connect all simulation lamps in place of Aerosol Generators and activate the isolation switch. | |
| 7 | Activate the system and ensure that all simulation lamps, light. | |
| 8 | Disconnect the simulation lamps from all Sequential Activators and measure the resistance of the Condensed Aerosol Generators to ascertain the normal resistance value. | |
| 9 | Connect the Condensed Aerosol Generators to the system. | |
| 10 | Upon completion, a certificate is issued to the responsible person. | |
| 11 | Visually inspect the room for possible openings / leakages. | |

6.0 MANAGEMENT BY USER

During its use, the fire suppression system needs to be kept in operational condition. To this end, at least the following activities are required:

6.1 MANAGER (TRAINED PERSON)

Persons trained and instructed to act as manager (trained person). A person is to be regarded as competent for the purposes of the Fire Suppression System where he has sufficient training and experience or knowledge and other qualities to enable him properly to assist in undertaking the preventative and protective measures.

| Date | Name | Responsibility |
|------|------|----------------|
| | | |
| | | |
| | | |
| | | |

6.2 PERIODICALLY CHECKS AND PRECAUTIONARY MAINTENANCE BY TRAINED PERSON (as per local regulations)

DAILY CHECKS

Check that the Fire Extinguishant Control Panel ascertain that it shows normal operational (panel power and trouble light).

| | J | F | M | A | M | J | J | A | S | O | N | D | Comments |
|---|---|---|---|---|---|---|---|---|---|---|---|---|----------|
| 01 | | | | | | | | | | | | | |
| 02 | | | | | | | | | | | | | |
| 03 | | | | | | | | | | | | | |
| 04 | | | | | | | | | | | | | |
| 05 | | | | | | | | | | | | | |
| 06 | | | | | | | | | | | | | |
| 07 | | | | | | | | | | | | | |
| 08 | | | | | | | | | | | | | |
| 09 | | | | | | | | | | | | | |
| 10 | | | | | | | | | | | | | |
| 11 | | | | | | | | | | | | | |
| 12 | | | | | | | | | | | | | |
| 13 | | | | | | | | | | | | | |
| 14 | | | | | | | | | | | | | |
| 15 | | | | | | | | | | | | | |
| 16 | | | | | | | | | | | | | |
| 17 | | | | | | | | | | | | | |
| 18 | | | | | | | | | | | | | |
| 19 | | | | | | | | | | | | | |
| 20 | | | | | | | | | | | | | |
| 21 | | | | | | | | | | | | | |
| 22 | | | | | | | | | | | | | |
| 23 | | | | | | | | | | | | | |
| 24 | | | | | | | | | | | | | |
| 25 | | | | | | | | | | | | | |
| 26 | | | | | | | | | | | | | |
| 27 | | | | | | | | | | | | | |
| 28 | | | | | | | | | | | | | |
| 29 | | 1 | | | | | | | | | | | |
| 30 | | | | | | | | | | | | | |
| 31 | | | 1 | | 1 | | | 1 | | | 1 | | |
| Note: Record problems found in the History log. | | | | | | | | | | | | | |

MONTHLY CHECKS

Year Planner:

| Comments | | J | F | M | A | M | J | J | A | S | O | N | D |
|---|---|---|---|---|---|---|---|---|---|---|---|---|---|
| 01 | Visual check Fire Extinguishant Control Panel to ascertain that it shows normal operation. | | | | | | | | | | | | |
| 02 | Visual check fire department panel. | | | | | | | | | | | | |
| 03 | Visual check relay panels if any. | | | | | | | | | | | | |
| 04 | Visual check of the Condensed Aerosol Fire Suppression System. | | | | | | | | | | | | |
| 05 | After consultation with the fire reporting station, check the relay for fire alarms by activating an alarm within the system. | | | | | | | | | | | | |
| 06 | Check the relay for failure alarms, e.g. by interrupting the primary power supply. | | | | | | | | | | | | |
| 07 | Check the correct reception of failure alarms. | | | | | | | | | | | | |
| 08 | Check visually whether manual "fire alarms" are easy to reach. | | | | | | | | | | | | |
| 09 | Check visually whether, both horizontally and vertically, the smoke detectors and the thermal detectors are at least 30 cm away from inventory. | | | | | | | | | | | | |
| 10 | Check visually whether all fire alarms are in a condition to function properly. | | | | | | | | | | | | |
| Note: Record problems found in the History log. | | | | | | | | | | | | | |

AT LEAST 4 & 8 MONTHS AFTER DELIVERY AND AFTER SERVICING BY THE CONTRACTOR

Year Planner:

| Comments | | J | F | M | A | M | J | J | A | S | O | N | D |
|---|---|---|---|---|---|---|---|---|---|---|---|---|---|
| 01 | Check whether within the detection zones there have been any changes to the use or layout of the areas, the ventilation system or structures. | | | | | | | | | | | | |
| 02 | Check whether the alarm organization plan still matches the current provisions. | | | | | | | | | | | | |
| 03 | Check whether the operational regulations, installation floor plans, block diagrams, functional matrices etcetera fit the actual situation. | | | | | | | | | | | | |
| 04 | Check the alarm function of all alarm groups. | | | | | | | | | | | | |
| 05 | Record the findings of all tests in this logbook. | | | | | | | | | | | | |
| 06 | Clean the exterior of the equipment. | | | | | | | | | | | | |
| Note: Record problems found in the History log. | | | | | | | | | | | | | |

6.3 PERIODICALLY CHECKS AND PRECAUTIONARY MAINTENANCE BY SERVICE EXPERT

Year Planner:

Note: It is important that operations for testing do not result in unwanted situations. Before start please do the followings:

- Ensure that the system will not activate the Condensed Aerosol Generators (PRESS THE ISOLATION SWITCH / ABORT BUTTON)
- Ensure that the alarm signal will not reach receiving center. (DISCONNECT VOICE COMMUNICATION SYSTEM)

| | Notes | Comments |
|----|---|----------|
| | Visual inspections: | |
| 01 | Visually inspect Fire Extinguishant Control Panel to ascertain that it shows normal operation. | |
| 02 | Visually inspect the Fire Extinguishant Control Panel for signs of moisture ingress or other deterioration. | |
| 03 | Visually inspect whether structural or occupancy changes have affected the requirements for the sitting of isolation switch / abort button, manual activation, detectors and sounders, sequential activators. | |
| 04 | Visually inspect to confirm that a clear space of at least 30cm is preserved in all directions below each detector. All points remain unobstructed. | |
| 05 | Visually check that all cable fittings and equipment are secure, undamaged and adequately protected. | |
| 06 | Visually inspect that the Condensed Aerosol Generators remain unobstructed. | |
| 07 | Visually inspect, ensure that the Condensed Aerosol Generators have the appropriate discharge length. | |
| 08 | Visually inspect the room for possible openings / leakages. | |
| | Fire Alarm Extinguishing control panel check: | |
| 09 | Inspect backup batteries. Examine batteries, their connections and testing. | |
| 10 | Simulate batteries failure. Ensure that the battery fault condition is activated. | |
| 11 | Check all ancillary functions of the extinguishing control panel, where possible. | |
| 12 | Check all fault indicators and circuits by simulating a fault condition. | |
| 13 | Simulate mains power supply failure and ensure that the backup batteries are providing the required power. | |
| | Extinguisher Check: | |
| 14 | Remove the E.O.L. component from the last sequential activator. Ensure that the Fire Extinguishant control panel detects the fault. | |
| 15 | Check activator wire and resistance. From sequential activator, disconnect the activator cable. By using an ohm meter ensure that the resistance of the activator is between 1.6-3.0 Ohms. | |
| | Clean Detector: | |
| 16 | Clean each detector for correct operation. | |
| | Check Alarm Conditions: | |
| 17 | Check that the Fire Suppression System is capable of operating under alarm conditions by operating at least one detector on one circuit (zone or loop) at a time. | |
| 18 | Check each detector for correct operation. | |
| 19 | Check each alarm sounder for correct operation. | |

| Check voice communication system: | |
|---|--|
| 20 | Check dialer trigger that automatic link to remote centers, if any. |
| 21 | Check dialer messages. |
| Simulate extinguishing alarm conditions: | |
| 22 | (1) Alarm Input Zone 1 of the Fire Extinguishant Control Panel -Ensure that the control panel detects the alarm and the 1 st stage is activated. -Ensure that the 1 st stage Horn/Strobe is active. |
| 23 | (2) Alarm Input Zone 2 of the Fire Extinguishant Control Panel -Ensure that the Control Panel detect the alarm and the 2 nd stage is activated. -Ensure that the 2 nd stage Horn/Strobe is activated and the Gas Release Sign indication is activated. |
| 24 | Ensure that the voice communication system activated. |
| 25 | Ensure that the extinguishing line is activated. |
| Commissioning | |
| 26 | De-activate the Isolation Switch / Abort Button |
| Ventilation Inspection: | |
| 27 | Inspect venting to Aid Fire Suppression System. |
| 28 | Inspect Fire Dampers and Fire Stop Flaps Logbook: |
| 29 | Check entries to logbook and ensure that necessary actions are taken. |
| 30 | Record any defects in a logbook |
| Certificate: | |
| 31 | Upon completion, a certificate of testing is issued to the responsible person. |
| Note: Record problems found in the History log. | |

Date:[...../...../.....]

Signed:[.....]

Name Signed:[.....]

8.0 CERTIFICATION

CERTIFICATION OF CONDENSED AEROSOL FIRE SUPPRESSION SYSTEM

This is to confirm that the following Fire Suppression System,
of the company / client [.....],
located at [.....],
has been designed in accordance to the applicable National, International, Local Standards,
Laws and Regulations. In addition, the above mentioned system has been designed, installed,
commissioned and tested as per manufacturer's (FirePro Systems) Specifications, Instructions
and Guidelines.

| | Full Name | Title | Signature | Date: |
|--|------------------|--------------|------------------|--------------|
| Designed by: Contractor / Consultant / Installer | ----- | ----- | ----- | ----- |
| Installed by: Contractor / Installer | ----- | ----- | ----- | ----- |
| Reviewed by: System Validation * See note d. | ----- | ----- | ----- | ----- |

DISCLAIMER:

- a. Any information provided by FirePro Systems, relevant to the design and application of the project is solely for guidance purposes and can be considered as such only.
- b. It is, therefore, the contractor's sole responsibility to verify whether the above circuit design is functional with the equipments used in his Application / System design. The responsibility to produce the actual design documentation, such as construction and as-built drawings, circuit diagrams, specifications etc., falls within the scope of the contractor responsible for the installation and commissioning (and certification if applicable) of the project. It is, therefore, the contractor's sole responsibility to ensure that all applicable National, International and local standards, laws and regulations are followed and applied.
- c. Cable sizes are indicative since they can vary depending on actual cable lengths and respective voltage drop calculations, which do not fall within the scope of FirePro Systems.
- d. System Validation refers to compliance with the guidance of the FirePro User Manual in respect to the relevant standard.

DISCLAIMER

FirePro Systems makes no representations or warranties of any kind, either express or implied, statutory or otherwise, including but not limited to warranties of merchantability, fitness for a particular purpose, of title, or of non-infringement of third party rights, including the intellectual property rights of others.

Any information provided by FirePro Systems, relevant to the system engineering of the project is indicative and for guidance purposes only.

LIMITATION OF LIABILITY

In no event, regardless of cause, shall FirePro Systems be liable for any indirect, special, incidental, punitive or consequential damages of any kind, whether arising under breach of contract, tort (including negligence), strict liability or otherwise, even if advised of the possibility of such damages.

NOTE

FirePro is constantly updating its products and systems to the state of the art and therefore reserves the right to make changes in design, equipment and technology. You cannot therefore base any claims on the data, illustrations or descriptions contained in this literature.

Address:
Tel.:
Email:

FirePro

Appendix 7

SERVER/IT ROOMS – DATA CENTRES APPLICATION GUIDELINES AND ACCIDENTAL ACTIVATION CONSIDERATIONS

To be read and used in conjunction with
FirePro Information, Instruction & User
Manual Version 8, May 2020

FirePro Systems Ltd

8 Faleas Str.,CY-4101 Limassol, CYPRUS
Tel.+357 25 379999, Fax.+357 25 354432
Web:www.firepro.com, email:mail@firepro.com
An ISO 9001:2015 & ISO 14001:2015 registered company

SERVER/IT ROOMS – DATA CENTRES APPLICATION GUIDELINES AND ACCIDENTAL ACTIVATION CONSIDERATIONS

Introduction

The aerosol extinguishing medium consists of minute solid particles suspended in a gaseous atmosphere (N_2 , water vapor, CO_2 and others), thus referred to as 'aerosol'. After discharge, the particles which are based on potassium compounds, as they are at the beginning free from moisture, settle as 'dust', which can easily be removed from the contact surfaces using basic cleaning means.

Warranty Disclaimer

FIREPRO MAKES NO WARRANTIES OF ANY KIND, EITHER EXPRESS OR IMPLIED, INCLUDING BUT NOT LIMITED TO WARRANTIES OF THE FIREPRO PRODUCTS FOR THEIR FITNESS FOR A PARTICULAR PURPOSE. FIREPRO CAN NOT BE HELD RESPONSIBLE FOR ANY COLLATERAL DAMAGES AFTER A FALSE OR ACCIDENTAL ACTIVATION OF THE SYSTEM DUE TO HUMAN ERROR OR OTHERWISE.

Residue

During the activation process the FirePro Compound (FPC) changes into a swiftly spreading aerosol, consisting of solid particles that are suspended in the gas phase. The size of these particles is a few micrometres/nanometres. The FirePro aerosol-forming compound is not based on halogen compounds to react with the fire. It does not produce any corrosive halogen acid by-products in its reaction with the fire.

The concentration of solid particles suspended in the aerosol phase is a few grams per m^3 . The particles are free from water and moisture and after a given period of time settle as dust in the protected room. The dust can easily be removed during cleaning before it absorbs moisture.

Following the fire extinguishing process, particles mainly consist of KOH in a very low concentration (which again reacts with CO_2 and rapidly change into K_2CO_3) and are also free from water and/or moisture.

If the aerosol particles are removed by cleaning shortly before they absorb moisture and they mix with combustion residues present in the air after the fire, they do not react to electronic components, metal etc. Where the dust particles remain for a lengthy period of time, they can absorb moisture, meaning that the moisture will react with metal (especially unpainted) so that oxidation could occur.

Important

When extinguishing gases liquefied under pressure are sprayed in the room cooling takes place. In the case of aerosol-forming units the temperature can rise. Both processes affect the humidity. It is therefore important to be aware of the humidity present beforehand. Following fire and/or activation of the extinguishing system the humidity in the room must be reduced as soon as possible.

Guidelines for the Removal of the Residue

- Remove the residue shortly after activation (within max. one hour).
- Use a damp cloth or brush to mop up the dry residue from the floor and/or metals.
- Use a fan to remove the residues from electrical components.
- Use special sprays that are suitable for removing/cleaning the residues from electronic components.
- Important: following a genuine and/or an accidental activation of the FirePro unit(s), you must always contact your dealer who can help you with a new survey of the room concerned and the correct reconditioning or cleaning methodologies.

The experience gained in the last few years indicates that if the electrical power is cut off from the room and if the residues are removed within one hour from the discharge time, minimum damage is incurred on the equipment.

The aerosol however, is hygroscopic in nature, that is, after being exposed for a length of time (depending on surrounding temperature and humidity), it can absorb moisture. Therefore if the aerosol particles are removed shortly after discharge, and before they absorb moisture, they will have no effect on the contact surface of electronic/electrical components, or affect their operation. If the aerosol particles are not removed, and remain for a prolonged length of time, they may absorb moisture, and it is the moisture that will react with any metal, possibly causing oxidation. The moisture, when in contact with live circuitry/electricity, may cause a short circuit, and likely cause damage.

Extensive corrosion tests on electronic boards have been carried out at NLR – National Aerospace Laboratory of the Netherlands; the electronic boards were exposed to the aerosol at design density (100 gr/m³) and then subjected to temperature/humidity cycles at +25°C / +55°C and 90 % humidity. No damage was incurred on the electronic boards (Please refer to the NLR Report).

Considerations:

The fact that in Server Rooms/Data Centres the operating temperature is below 25°C (lower temperature at which NLR assessed the aerosol agent impact on electronics) may cause a faster condensation of the aerosol on cold surfaces and accelerate the absorption of moisture. Therefore this mixture of moisture, aerosol, dust (always present in data rooms) and combustion debris (if a fire is present) in the form of a dark oily residue can cause problems on electronics, if not removed before putting the equipment into operation.

Indeed if there are discharges, say due to human error, the difference between following procedures and not following procedures can be enormous. Therefore, please ensure that the below steps are strictly followed.

POWER CUT OFF

As part of the installation procedure you should isolate power to the Air conditioning, forced ventilation and any other equipment in the room. The FirePro Extinguishing Control System must be integrated to automatically isolate the power to the equipment before aerosol discharge.

Shutdown of Energy Supply and Computers

The activation system of the FirePro units is to be planned so that the following expectations/conditions are met:

1. The ventilation system of the room to be protected must be shut down before the FirePro system is activated. The power supply to the equipment/installation must also be shut down so that the ventilation and/or blowing function of the equipment is stopped. In this situation the fire cannot spread by means of extra oxygen and the extinguishing agent can reach the fire with guaranteed swiftness and in the desired concentration and extinguish it efficiently.
2. The shutdown system for the power supply also guarantees that there is no short-circuiting following activation. Any additional fire risk is prevented by the shutdown system.
3. The shutdown system for the power supply and ventilation is connected to the fire detection and fire alarm system and/or fire alarm panel.
4. Ventilate the room soon after discharge by extracting the discharged aerosol. This also reduces the aerosol condensation rate and humidity.
5. As soon as practically possible, clean equipment using cloths, special moisture removing fluid/sprays, or blower/vacuum cleaner as may be necessary, before putting the equipment in operation.

Additional Points to be Considered.

The areas where the aerosol settles most is the cooling fan and power supply (which is placed behind the fan) and equipment cold surfaces. This happens because the cooling fan is working continuously and is blowing a large quantity of aerosol inside the equipment (more quantity than the design application density used volumetrically).

Within the first hour of operation after discharge, the aerosol starts to absorb moisture; in cold (air conditioned) environments and high humidity this physical process is accelerated.

If some damage is incurred mainly in the power supply, this component can be easily replaced, and the whole equipment will function properly.

Only the damaged component needs to be replaced and not the entire equipment.

Additional information on how to clean the electronic components:

Aerosol Spray Cleaners

These aerosols sprays have been specially created to remove dust, condensation, grease, oil, flux, grime, and other particulate matter from delicate electronic circuitry. Its quick dissolving formula does the job in a hurry and doesn't leave any residue behind. In addition to cleaning circuit boards, precision instruments, and electrical motors it also does an excellent job in cleaning switches, contacts, wire terminals, circuit breakers, relays, potentiometers, tuners, control panels, cable ends and receptacles, and other electronic equipment.

| Electra XL | Safety Wash Liquid 4050 | Maplin N64AN |
|--|--|--|
|  |  |  |

How to Clean an Electronic Circuit Board

Instructions

- Unplug the electronic device immediately after the spill. Any sort of liquid can potentially cause a shock when combined with electric current. Protect yourself by removing any source of power to a wet device.
- Disassemble the device to expose the circuit board. Take the device apart carefully, according to its directions. You want to put it back together afterward, so the outer parts should stay intact.
- Soak up any remaining liquid with a lint-free cloth. Do not use paper products, since these could leave lint or scratch the board. Do not rub any cloth on the circuit board, since this could scratch or dislodge the parts. Place the cloth over the board and press gently. This will soak up the liquid.
- Remove the worst of any remaining particles by brushing with a toothbrush. This includes any globs of dried liquid. It does not need to be perfect at this stage. Remove any dust or loose pieces of dried liquid by spraying compressed air. Spray in one direction in quick bursts, since the canister can become extremely cold if used for longer sprays.
- Pat the board gently with a cloth to remove the majority of the moisture and allow it to dry completely. Reassemble the device and test it. Many devices, from cellphones to computer keyboards, can survive a brief spill or dunking by drying and cleaning them, and they will continue to work after you put them back together.

